

Experimental Psychology

TITCHENER

I

Part 1-2

EXPERIMENTAL PSYCHOLOGY

EXPERIMENTAL PSYCHOLOGY

A Manual of Laboratory Practice

BY

EDWARD BRADFORD TITCHENER

VOLUME I

QUALITATIVE EXPERIMENTS:

PART I. STUDENT'S MANUAL

*As an experimentalist, I feel bound to let experiment
guide me into any train of thought which it may justify.*
— FARADAY.

New York

THE MACMILLAN COMPANY

LONDON: MACMILLAN & CO., LTD.

1902

All rights reserved

JOHNSON REPRINT CORPORATION

New York • London

1971

COPYRIGHT, 1901,
By THE MACMILLAN COMPANY.

Set up and electrotyped February, 1901. Reprinted April,
1902.

Library of Congress Catalog Card Number: 70-175926

First reprinting 1971, Johnson Reprint Corporation



Johnson Reprint Corporation
111 Fifth Avenue
New York, N.Y. 10003, U.S.A.

Johnson Reprint Company Ltd.
24/28 Oval Road
London, NW1 7DD, England

Printed in the U.S.A.

TABLE OF CONTENTS

INTRODUCTION

DIRECTIONS TO STUDENTS

	PAGE
§ 1. Conduct of an Experiment	xiii
§ 2. General Rules of Laboratory Work	xiv
§ 3. Laboratory Partnerships	xv
§ 4. Note-Book	xvi
§ 5. Definitions	xvii

PART I

SENSATION, AFFECTION, ATTENTION AND ACTION

CHAPTER I. VISUAL SENSATION

§ 6. Sensation	I
§ 7. Visual Sensation	3

EXPERIMENT I

§ 8. The Laws of Colour Mixture	5
---	---

EXPERIMENT II

§ 9. The Distribution of Colour Sensitivity over the Retina: Cam- pimetry	9
--	---

EXPERIMENT III

§ 10. The Phenomena of Visual Contrast	15
--	----

EXPERIMENT IV

§ 11. Visual After-images	22
-------------------------------------	----

CHAPTER II. AUDITORY SENSATION

§ 12. Auditory Sensation	31
------------------------------------	----

EXPERIMENT V

§ 13. The Phenomena of Interference: Beats	35
--	----

	PAGE
EXPERIMENT VI	
§ 14. The Pitch Difference of the Two Ears	38
EXPERIMENT VII	
§ 15. Combination-tones	39
EXPERIMENT VIII	
§ 16. Pitch and Clang-tint	46
EXPERIMENT IX	
§ 17. Analysis of Simple Clang: Overtones	49
CHAPTER III. CUTANEOUS SENSATION	
§ 18. Cutaneous Sensation	52
EXPERIMENT X	
§ 19. Temperature Spots	54
EXPERIMENT XI	
§ 20. Temperature Sensitivity: Areal Stimulation	57
EXPERIMENT XII	
§ 21. Pressure Spots	58
EXPERIMENT XIII	
§ 22. Pain Spots	60
CHAPTER IV. GUSTATORY SENSATION	
§ 23. Gustatory Sensation	63
EXPERIMENT XIV	
§ 24. Distribution of Taste Sensitivity over the Tongue: Taste Reactions of Single Papillæ	64
EXPERIMENT XV	
§ 25. The Number of Discriminable Taste Qualities	67
EXPERIMENT XVI	
§ 26. Taste Contrasts	68

CHAPTER V. OLFACTORY SENSATION

	PAGE
§ 27. Olfactory Sensation	70
EXPERIMENT XVII	
§ 28. The Field of Smell	73
EXPERIMENT XVIII	
§ 29. The Olfactory Qualities: Method of Exhaustion	76
EXPERIMENT XIX	
§ 30. The Olfactory Qualities: Compensations, Mixtures, Contrasts	79

CHAPTER VI. ORGANIC SENSATION

§ 31. Organic Sensation	87
EXPERIMENT XX	
§ 32. The Sensation of Muscular Contraction	88

CHAPTER VII. THE AFFECTIVE QUALITIES

§ 33. Affection	91
EXPERIMENT XXI	
§ 34. The Affective Qualities: Method of Impression	92
EXPERIMENT XXII	
§ 35. The Affective Qualities: Method of Expression. (1) Involuntary Arm Movement	95
EXPERIMENT XXIII	
§ 36. The Affective Qualities: Method of Expression. (2) Muscular Strength	100
EXPERIMENT XXIV	
§ 37. The Affective Qualities: Method of Expression. (3) Bodily Volume	103

CHAPTER VIII. ATTENTION AND ACTION

EXPERIMENT XXV

	PAGE
§ 38. Attention	108

EXPERIMENT XXVI

§ 39. The Simple Reaction	117
-------------------------------------	-----

PART II

PERCEPTION, IDEA AND THE ASSOCIATION OF IDEAS

CHAPTER IX. VISUAL SPACE PERCEPTION

§ 40. Perception	127
----------------------------	-----

§ 41. Visual Space Perception: Preliminary Exercises	130
--	-----

EXPERIMENT XXVII

§ 42. Visual Space Perception: Stereoscopy	137
--	-----

EXPERIMENT XXVIII

§ 43. Visual Space Perception: Pseudoscopy	144
--	-----

EXPERIMENT XXIX

§ 44. Visual Space Perception: the Geometrical Optical Illusions	151
--	-----

CHAPTER X. AUDITORY PERCEPTION

EXPERIMENT XXX

§ 45. The Degrees of Tonal Fusion	171
---	-----

EXPERIMENT XXXI

§ 46. Rhythm	174
------------------------	-----

EXPERIMENT XXXII

§ 47. The Localisation of Sound	178
---	-----

CHAPTER XI. TACTUAL SPACE PERCEPTION

EXPERIMENT XXXIII

§ 48. Localisation of a Single Point upon the Skin	184
--	-----

EXPERIMENT XXXIV

	PAGE
§ 49. Localisation upon the Skin : Discrimination of Two Points	186

EXPERIMENT XXXV

§ 50. Localisation upon the Skin : Stimulation of Parts whose Relative Position may be Changed	190
--	-----

CHAPTER XII. IDEATIONAL TYPE AND THE ASSOCIATION OF IDEAS

EXPERIMENT XXXVI

§ 51. Ideational Types	195
----------------------------------	-----

EXPERIMENT XXXVII

§ 52. The Association of Ideas	200
--	-----

LIST OF MATERIALS	207
-----------------------------	-----

INDEX OF NAMES AND SUBJECTS	211
---------------------------------------	-----

INDEX OF FIGURES

FIG.	PAGE
1. The Colour Pyramid	3
2. The Solar Spectrum	4
3. Colour Mixers	6
4. Campimeter	10
5. Apparatus for the Observation of Negative After-images	27
6. The Series of Auditory Qualities	33
7. Cheap Tuning Forks	35
8. Set of Quincke's Tubes	40
9. Quincke's Tube, stopped and labelled	44
Figure showing the First Ten Partial of the Note <i>C</i>	50
10. Differential Sonometer	50
11. Temperature Cylinder	54
12. Pressure Point	59
13. Pain Point	61
14. Double Olfactometer	80
15. Upright Inductorium	88
16. Motor Points of the Fore-arm	90
Tables for Paired Comparison	93, 94
17. Automatograph	96
18. Finger Dynamometer	100
19. Franck's Plethysmograph	103
20. Kymograph	104
Chord to demonstrate Intensification by Attention	111
21. Vernier Chronoscope	118
22. Space Vernier	120
23. Ophthalmotrope	135
24. Hand Stereoscope	139
25. Table of Spatial Conversion	145
26. Total-reflexion Pseudoscope	146
27. Pseudoscopic Figure	149

FIG.	PAGE
28. Arrangement of Objects for Pseudoscope	149
29. Optical Illusions : Hering's Crosses	153
30. Optical Illusions	154
31. Optical Illusions : Schröder's Stair Figure	155
32. Optical Illusions : Necker's Cube	155
33. Optical Illusions : Thiéry's Prisms	156
34. Optical Illusions : Oppel's Lines and Helmholtz' Squares	157
35. Optical Illusions : Láska's Figure and Variants	158
36. The Müller-Lyer Illusion	159
37. The Illusions of Oppel, Delbœuf and Kundt	160
38. Optical Illusions : Oppel's Angles	160
39. Optical Illusions : the Figures of Hering and Wundt	161
40. Optical Illusions : Zöllner's Figure	162
41. Poggendorff's Illusion	162
42. Optical Illusions : Helmholtz' Chess-board	163
43. Illusions of Association : Wundt	163
44. Illusions of Association : Wundt, Müller-Lyer	164
45. Mixed Illusions	165
46. Poggendorff's Illusion	165
47. Mixed Illusions : Müller-Lyer	165
48. Mixed Illusions : Müller-Lyer, Wundt	166
49. Optical Illusions	167
50. Optical Illusions	167
51. Optical Illusions	168
52. Optical Illusions	169
53. Optical Illusions	170
54. Metronome	175
55. Sound Cage	179
56. Simple Æsthesiometer	187
Æsthesiometric Table	189
57. Association Apparatus	202

INTRODUCTION: DIRECTIONS TO STUDENTS

§ 1. **Conduct of an Experiment.** — A psychological experiment consists of *an introspection or a series of introspections made under standard conditions.*

Some experiments are best performed by oneself on oneself. Most, however, require two persons for their performance: the observer *O*, who makes the introspection, and the experimenter *E*, who handles the instruments and makes the records. All experiments of this kind must be made twice over, *O* and *E* changing places. Each student keeps the record of his partner's introspective results, not that of his own; so that it is his partner, and not he himself, who figures as *O* in his note-book. There should be no mutual discussion of results until the experiment is completed. Never, under any circumstances, must the idea of *competition* with one's partner be allowed to enter into the work. For the psychological experiment is not a test of power or faculty or capacity, but a dissection of consciousness, an analysis of a piece of the mental mechanism. The idea of rivalry is fatal to introspection.

The student who acts as *E* during the first part of a laboratory period has a certain advantage over his partner. When he comes to act as *O*, his introspection will, evidently, be guided to some extent by his knowledge of the instrument used, and of the outcome of his partner's introspection. Hence it is advisable to alternate the functions of *O* and *E*; the student who begins as *O* to-day, should begin as *E* on the next day of class work, and so on.

There are certain experiments in which it is necessary to let *O* write his own introspective record, while *E* attends wholly to the instruments and method. This happens, *e.g.*, when *E* and *O*

are placed in different rooms which are electrically connected for the performance of some special piece of work. Wherever possible, however, *O* should dictate his introspections to *E*. In this way, *O* gains practice in the translation of mental processes into words; *E* can put questions where he does not fully understand a statement. If *O* be left to write out his own report, he will probably use general terms and stock phrases, which are intelligible to him (because they are eked out by his memories), but which convey little psychological information to another reader. Whenever *O* is obscure or vague, *E* must question him, and hold him strictly to the definite and concrete.

Do not begin an experiment until you thoroughly understand its object, *i.e.*, the point upon which your introspection is to be directed, and can see the reasons for the method which you are to follow in performing it. It is better to waste half an hour at the start than to waste the whole time spent upon the experiment.

You will find, on the average, that three-quarters of an hour of introspective work is all that you can satisfactorily accomplish at a sitting. Hence the total experiment should be performed, if possible, in an hour and a half. If this is not feasible, some portion of it should be left over for the next laboratory period. You must use your judgment in deciding what part can be postponed with least derangement of the method.

§ 2. **General Rules of Laboratory Work.** — It is a cardinal rule of laboratory work that you should never vary your method during a series of experiments. Such variation is unfair to *O*, and bad for the final results. It is very tempting, when you have chosen a method that does not run quite smoothly, to repeat an experiment that should not be repeated, or modify one that should not be modified. But you must remember that one of the conditions of valid results is that *O* be kept in an even frame of mind. If you play tricks with him, after you have arranged the experiment, he will grow restless and unsteady, and his introspection will be valueless. Of course, it may be worth while, at times, to make a special experiment, in order to discover what change in results follows from this or that unexpected change in the experimental method. An experiment of this sort can be explained and justified to *O* after it is over. But never desert your method in your regular work. If the

results are disappointing, try to account for their irregularity ; do not try to juggle them into regularity. That may answer for the moment ; it will be bad in the long run.

Do not slight an experiment because you know that its results will necessarily be rough, and not of the accurate sort that are quoted in the text-books of psychology. This would, again, be unfair to your partner, while it would render the whole exercise worthless to yourself. Every experiment is a lesson in introspection and in general scientific method. No apparatus will be put into your hands that is not adequate to these two purposes. It is the bad workman who quarrels with his tools.

Do not call upon the Instructor at every hitch ; try to overcome the difficulties for yourself. If, however, after you have completed an experiment, you find that you have passed over some essential point of method, or neglected some source of error, consult with the Instructor before repeating it. The record of the experiment as performed, with emphatic statement of the mistakes, may be considered by him as more valuable to you than the same experiment correctly performed at a double expense of time.

If such an experiment — an experiment in which some error has been made — ‘comes out right,’ *i.e.*, leads to results which tally with the results gained by a correct method, do not on that account be content with it and enter it in your note-book as if nothing were wrong. Go over the details with the Instructor, and try to find out the reason for the ‘good’ results. The error into which you fell must have been compensated by some contrary error, of which you have not been aware.

Work as quietly as possible. Even if you and your partner are given a separate room to work in, apart from the rest of the class, the habit of silence is a good one.

Report promptly any accidental injury done to the instruments while they are in your charge.

§ 3. **Laboratory Partnerships.** — It follows from what has been said, that the student of psychology is not able to work entirely by himself for himself ; *O* is dependent upon *E*, and *E* upon *O*. Each must do his very best for the other. Laboratory partnerships should be continued, if possible, throughout the year ; at

least, throughout a term or semester. If either member is unable to be present at a particular class exercise, he should notify the other beforehand. Otherwise, time is lost by the student, and needless trouble given to the Instructor.

If you are to act as *O*, and your partner as *E*, do not be impatient for him to begin work all in a moment; remember that he is responsible for the method. If the class regulations make it necessary for you to work when you are tired or preoccupied or unwell, do not fail to inform your partner of the circumstance, that he may be on his guard against the disturbing influences and record them in his note-book. Tell him everything that you are aware of, by introspection, as affecting the experiment. If, *e.g.*, you are working on an 'illusion,' and you are conscious of a tendency to correct the illusion, mention the fact to him early in the experimental series; he has to explain your results, and may spend much time in puzzling over a matter that a little care on your part would have cleared up at once. No piece of true introspection is too trivial to speak of. Notice slips of attention, insistent memories, outside disturbances, variations of mood, etc., etc.

If you are to act as *E*, take care that *O* is comfortable before you begin experimental work. Be sure that he distinctly understands what is required of him. Look out for external signs of shift of attention, fatigue, distraction, etc. Be very careful, however, not to suggest to him in any way that you wish or expect him to find this or that particular fact by introspection at this or that particular moment. Introspection is never easy; it becomes doubly difficult when one knows that *E* desires one to reach a predetermined result. Many experimental series have been spoiled by some suggestion from *E*, and an answering complaisance on the part of *O*.

Punctuality, considerateness, an alert attention and strict truthfulness are necessary to a congenial and fruitful partnership.

§ 4. **Note-book.** — As you work, jot down the results of your experiment upon rough paper. As soon as possible after the ending of the laboratory period, work up these notes, and write the experiments out in a large note-book, which should be ruled and paged. Write on one side of the page only. Number your

experiments both in the order of their performance and in the order of this Course ; make an index, at the end of the note-book, in which both of these numbers are given. Use black, red and violet inks : black for general description, red for results, violet for noteworthy points in the description (evidence of particular errors, important pieces of introspection, unexplained facts, etc.). Abbreviate throughout ; never write, in full, words like 'millimetres,' 'introspection,' 'expectation.' Keep to a single scheme or pattern in your accounts of experiments. State (1) the *number* of the experiment, together with the *date* and *hour* of its performance, the *names* of *E* and *O*, and the general *physical condition* of *O* ('fresh,' 'tired,' 'headachy,' etc.). Then (2) note succinctly the *problem* which it attacks, and (3) the *instruments* which you employ and the *method* which you follow. After this, put down (4) the *results* which you have obtained, — both the numerical results, and the general conclusion to be drawn from the experiment. Finally, (5) append *remarks* upon special points, and *references* to psychological works in which the problem and its bearings are discussed. Do not repeat, in your accounts, the statements of this Course ; the note-book is to be a companion to the printed book, not a substitute for it. Have your note-book revised, say, once a month, by the Instructor. Do not be afraid of offering your own explanations of the facts you obtain, — the Instructor can put you right if you have gone astray, — but, on the other hand, do not lose sight of these facts and speculate at haphazard. Face the facts themselves, and try to account for them in the light of all that you know. Enter the Instructor's corrections and suggestions on the blank pages of your note-book, so that your work is kept separate from his.

§ 5. **Definitions.** — Mention has been made, in the foregoing Sections, of Introspection, Experiment, Explanation, etc. Before you begin the Course, refresh your memory of the definitions of these terms. Learn the definitions so thoroughly that they become automatic with you, a permanent item of the mental furniture that you bring with you into the laboratory. Apply them in every exercise that you perform.

Further : before you begin any particular Chapter of the

Course, look up the definition of the special mental process which you are going to investigate. If it is a complex process, try clearly to realise its relation to, and difference from, the elementary processes of which it is composed.

If you follow these rules, every experiment will be seen to have its own proper place in a system of psychology. It will not stand alone, as something to be done, — and done with ; it will suggest more problems, and throw light upon other experiments. Ask yourself, when you have completed some dozen experiments, whether there is any reason for your having performed them, whether they promise to help you towards understanding the make-up of the human mind. You will not see the reason for the choice of each particular experiment that the Course offers, any more than as a child you saw the reason for the particular sequence of rules in your English Grammar. But you should be able to see, at least vaguely, what it is that the Course is aiming at. If you cannot, if the wood is obscured by the trees, talk the work over with the Instructor. Do not go on in the dark.

EXPERIMENTAL PSYCHOLOGY

PART I

SENSATION, AFFECTION, ATTENTION AND ACTION

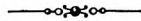

CHAPTER I

VISUAL SENSATION

§ 6. **Sensation.** — We said in § 1 that the psychological experiment is “not a test of power or faculty or capacity, but a dissection of consciousness, an analysis of a piece of the mental mechanism.” Now, it is the aim of analysis or dissection to split up a complex whole into simpler parts, and so ultimately to reduce it to its elements, the very simplest factors of which it is compounded. You can see, then, even before you have performed a psychological experiment, that an analysis of some particular section of consciousness means the splitting-up of it into simpler and simpler mental processes, until finally it reveals itself as a complex of elementary processes, beyond which we cannot go.

If we take some such section of consciousness (say, a memory-consciousness, our mind as it is when we are remembering something, — or an imagination-consciousness, our mind as it is when we are imagining something, — or a thought-consciousness, our mind as it is when we are arguing something out) and analyse it, we find that it reduces to a number of quite simple processes, all of the same general kind or class. These are called *sensations*. The sensation, then, is the structural unit or structural element of these consciousnesses, — just as the cell (so the anatomists and physiologists tell us) is the structural element

of our bodily tissues. If we wish to understand the make-up of mind, we must know all about these sensations.

We might—and this may seem, at first sight, the more obvious thing to do—take some complex consciousness, such as the memory-consciousness, and analyse it for ourselves, in order to test the statement that it can be split up into sensation elements. But this would really be wasting time. For we do not yet know what a sensation is; we should not be able to recognise it, if we came across it. We should be struggling, ignorantly, to solve a difficult problem by ‘common sense,’ and neglecting the skilled work of those who have attacked the problem before us, —work that would spare us much futile effort and many errors. Or, to put it differently, instead of getting a map and following the high-road, we should be pushing across country, by the help of a pocket compass, toward a town which we know to lie in a certain direction.

What we shall rather do, then, is to begin with an examination of sensations, in the light of the experimental work already done. When we are thoroughly familiar with the mental elements, we shall know what sort of thing to look for in our analyses of complex processes: our dissection will be surer and safer, and we shall be better able to grasp the pattern of these complexes, to trace out the peculiar forms of mental connection. And you need not fear that this method makes things too easy: that you will be spared the wholesome effort of original thinking, or miss the taste of success achieved by a first-hand grapple with difficulties. Scientific method does not try to make things easy; but it does try to prevent waste of time, to secure a quantum of scientific advance for every quantum of time spent.

Indeed, at the very beginning, a task is set you that is not wholly easy. It is, to get a clear idea of the meaning of ‘sensation’; to have the definition of the term ingrained in the texture of your mind; to provide yourself in this way with a blank form which shall be filled out by the results of actual experiment; and, further, to shake yourself free from a good many errors of popular psychology. The Instructor can give you some help, and the progress of the work itself will give you still more; but the initiation into psychology is always a self-initiation.

Whether there are other kinds of mental element, besides sensation, is a question with which we need not concern ourselves at this time.

§ 7. **Visual Sensation.** — There are two classes of visual sensations: colours proper, and ‘neutral colours’ or brightnesses. The former class includes red, green, blue, etc.; the latter contains the blacks, whites and greys. The two kinds of sensation are intimately associated in our experience. We never see a colour that is not intermixed with a certain brightness; and we rarely, if ever, see a ‘neutral colour’ that is not tinged by some true colour. We are thus led to introduce the word ‘saturation’ into the terminology of visual sensation. The redder a red, the more of redness it has, the more ‘saturated’ is it; the pinker or browner a red, the less redness it has in proportion to its white or black component, the less ‘saturated’ is it. In the same way, we might call the black of velvet a more saturated black than that of black paper or cardboard; and the white of baryta paper a more saturated white than the white of ordinary note-paper.

The whole number of visual sensations is represented in Fig. 1. The dotted vertical WB corresponds to the white-black series; the base, to the most saturated colours,—red, orange, yellow, yellow-green, green, blue-green, blue, violet, purple. The following Questions arise.

(1) What do we find on the outside of the colour pyramid? What should we find if we peeled the whole figure, like an onion? What should we find upon a cross-section (plane of latitude)? Upon a longitudinal section (plane of longitude)?

(2) Why do we take a quadrilateral figure (and not, *e.g.*, a circle) as the base of the double pyramid? Why is the base tilted, with the point Y highest and the point B lowest?

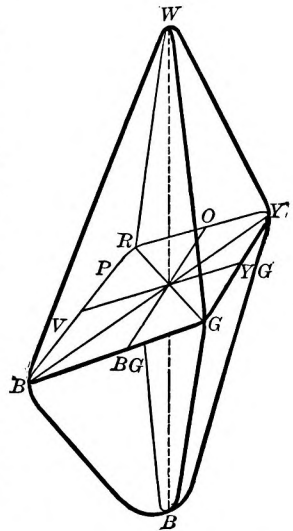

FIG. 1.—The Colour Pyramid.

(3) What determines the length of the sides RY , YG , GB , BR ? What determines the angles BRY , RYG , etc.?

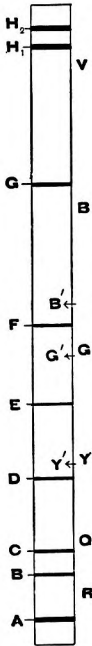

FIG. 2. — The solar spectrum (dispersion spectrum). The letters on the left indicate the principal Fraunhofer lines; those on the right, the names of the spectral colours. Y' is Hering's *Urgelb* ($\lambda = 577 \mu\mu$; $n = 521$ billions); G' is the *Urgrün* ($\lambda = 501 \mu\mu$; $n = 599$ billions); and B' the *Urblau* ($\lambda = 477 \mu\mu$; $n = 629$ billions). The *Urroth* lies outside of the spectrum; it is a slightly purplish red, as the *Urgrün* is a slightly bluish green.

(4) Why is the B -pole rounded off at a lesser distance from the base than the W -pole?

It is clear that our visual sensations form a continuous, tri-dimensional manifold, and that any given visual impression can be adequately defined by the three properties of (*a*) colour or colour-tone (longitude), (*b*) brightness (latitude), and (*c*) saturation (distance from the axis).

The external stimulus of vision is light, a vibration of the luminiferous ether. Ether waves of a single wave-length (homogeneous light) arouse the most saturated colour sensations; the addition of waves of other wave-lengths dulls the colour. White and grey are set up, under ordinary circumstances, by a mixture of waves of all possible wave-lengths (mixed light). Black, in physics, is a negative term, implying the absence or the total absorption of light. — It is plain that there are great discrepancies here between physics and psychology. A dull blue is as simple a sensation, for psychology, as a saturated blue; white is as simple a sensation as red; and black is as positive a sensation as green.

These difficulties must be resolved by an appeal to the link that connects light with vision, — the physiology of the eye. We have in the visual apparatus three visual substances: a black-white, a blue-yellow and a red-green substance. The

processes in each substance are antagonistic: black, blue and green are processes of assimilation, and white, yellow and red processes of dissimilation.

Question (5) Sketch the Helmholtz and the Hering theories of visual sensation.

(6) Define: fundamental colour, principal colour, mixed colour, original colour (*Urfarbe*).

(7) What are the chief problems of the psychology of visual sensation?

PRELIMINARY EXERCISE. — A good introduction to colour work is a careful introspective examination of the solar spectrum. Let *E* and *O* seat themselves before the spectrum chart, and note down as many points of psychological importance as they can discover in it. They may discuss the points with each other, and talk out each other's suggestions. At least four facts should be brought out by half-an-hour's introspective consideration.

EXPERIMENT I

§ 8. **The Laws of Colour Mixture.** — The object of this experiment is to verify the three laws of colour mixture. These are: (1) that for every colour there can be found another, complementary or *antagonistic* colour, which if mixed with it in the right proportion gives a brightness quality (white or grey), and if mixed in any other proportion an unsaturated colour of the tone of the stronger component; (2) that the mixture of any two colours which are not complementaries gives an intermediate colour, varying in colour-tone with the relative amounts of the two original colours, and varying in saturation with their nearness or remoteness in the colour series; and (3) that the mixture of any two combinations which match will itself match either of the original combinations, provided that the illumination of the colours remain approximately the same.

MATERIALS. — Colour mixer. Two sets of discs, large (20 cm.) and small (11 cm. diam.), of coloured and colourless (black, white, grey) papers: all slit along one radius. Neutral grey screen. Protractor.

PRELIMINARIES. — The conditions of successful colour mixture by rotating discs are: (1) that the discs be properly centred, so

that they do not 'wobble' during rotation; (2) that the radial slits be accurately cut, and the measurements of degrees (added and subtracted) accurately made; (3) that the discs rotate at least 40 to 50 times per second, so that there is no flicker.— If the coloured papers are thin, put first of all upon the mixer a disc of thin cardboard, to serve as support. The mixer may stand, or lie horizontally, as *O* prefers. In either case, the discs must be viewed against the neutral grey background, and must be uniformly illuminated, *i.e.*, free from shadows. Time and place should be so chosen that the illumination will remain practically constant during the experimental sitting.

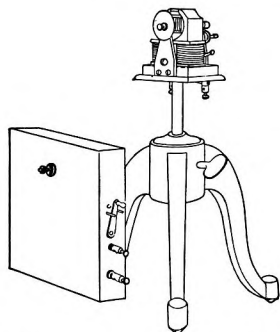

FIG. 3.—Two forms of electric-motor colour mixer. That to the left is made by The Chicago Lab. Supply Co., \$3.00; that to the right by E. Zimmermann, Mk. 30.

EXPERIMENT (1).— The complementaries are: carmine and bluish green, red and verdigris, orange and greenish blue, yellow and blue, yellowish green and violet, green and purple, bluish green and carmine, etc. In all probability there will not be found, among the coloured papers, single discs that exactly represent all these colours. Red, *e.g.*, will very probably be a distinctly orange red. Hence, if mixed with verdigris (slightly-bluish green, or strongly-greenish blue), it will give not a grey but a brownish (somewhat orange) grey. The orange must be taken out of the mixture by the addition of a little of *its* complementary; *i.e.*, the mixture must consist not of two discs, red and verdigris, but of three, red, verdigris and a greenish blue.

The complementaries are to be found by mixture with the large discs. When such a mixture seems to have resulted in a pure grey, two small discs, of black and white, are to be mounted on the mixer, over the large coloured discs. The proportions of black and white must be varied, until the two greys match. If the comparison with real grey brings out a tinge of any colour in the mixture from the large discs, a trifle of the complementary

of that tinge must be added to the original mixture (whether by the insertion of another large disc, or by variation of the proportions of the discs already in use). The match is to be made precise, both as regards colour and as regards brightness.

If it is impossible to predict, approximately, what the proportions must be in a given instance, it is best to work from equality of parts, to begin with discs of 180° of the one colour or brightness and of 180° of the other. The methodical way is the shortest way to arrive at the goal. A record of the mixtures is to be kept, and the reason shown for every addition or subtraction of colour or brightness.

Six experiments are to be performed, as indicated in the list of complementaries above. A few mixtures should also be made to illustrate the fact that excess of either component in a complementary mixture means an unsaturated colour of the tone of the prevailing component.

(2) *Second Law.* — Put together two large discs, of red and yellow, in equal parts. Mix. Vary, until the best possible orange is attained. Then put together small discs, of orange and black, or of orange, black and white. Lay these over the large discs on the mixer. Vary the proportions until the two oranges match, both in colour tone and in brightness.

Mix other colours in the same way: yellow and green, to give a yellowish green; purple and blue, to give violet; blue and green, to give bluish green; green and violet, to give blue; red and blue, to give carmine, violet and purple. Match the mixture with a single coloured paper (or with this, mixed with black or white or both) in every case. Keep records of each trial and its result. Do not take proportions at haphazard: if you cannot foresee the relative proportions, approximately, work again from equality of parts. — With some colours, it may be best to keep the small disc pure, and to vary the large, by addition of black or white. Let experience decide.

Take careful notes as regards the relative saturation of the different mixtures.

(3) *Third Law.* — Mix red and verdigris (small discs) to match a grey (large discs). Then match this *same* grey with a mixture of orange and greenish blue: add black or white to the

orange and greenish blue mixture, if necessary. Evidently, the two colour mixtures will match. Now make up a mixture (large discs) composed of 180° of the red and verdigris mixture, and of 180° of the orange and greenish blue mixture. Lay over this, on the mixer, (1) the red and verdigris mixture, and (2) the orange and greenish blue mixture. Note that the combination of mixtures matches both of the original mixtures.

The same thing may be shown in a slightly different way, as follows. Match a grey (black and white) with a mixture of purple and green. Match another grey (black and white) with a mixture of yellowish green and violet. Now make up a compound mixture (large discs) of 180° of the first and 180° of the second colour mixture. Make another compound mixture (small discs), of 180° of the grey which matched the first, and 180° of that which matched the second colour mixture. Put these two compound mixtures on the mixer. Note that they match.

Once more: get a brownish yellow by mixing red and green (large discs); match it, on the small discs, with a mixture of orange and grey. Make up a compound mixture, of 270° of the one mixture and 90° of the other. Note that this compound mixture matches both the original mixtures.

To show the necessity of approximate constancy of illumination, you have only suddenly to cast a deep shadow upon the mixer, while it is carrying a compound mixture and one of the simple mixtures which matches it. You will find that one of the sets of discs immediately appears lighter than the other. The result is seen very prettily with the red-verdigris-greenish-blue-orange compound mixture, on the large discs, and either the red-verdigris or the orange-greenish-blue mixture, on the small. — It follows, from this change of brightness, that the third law of colour mixture is valid only under certain conditions; and that these conditions are not realised when the original illumination of the mixtures, *i.e.*, that under which the colour equations were first obtained, is materially varied.

RESULTS. — *E* has his sets of equations, and the introspective notes referring to relative difficulty of match, etc. His records should contain at least one full series of determinations: *i.e.*, an account of all the steps whereby the equation was reached,

together with the reasons for change at each point. The following Questions arise.

E (1) What are the characteristics of a good series of coloured papers?

O (2) What unexpected help did you get from sensation itself in the matches of exp. (3)?

E and *O* (3) What corollaries, as to the results of mixing three or more colours together, can you derive from the three laws?

E and *O* (4) What other modes of colour mixing can you suggest? Which of them do you recommend? What are the advantages of mixing by rotating discs?

Questions to be answered from the literature:

(1) How do Helmholtz and Hering respectively explain the phenomena of colour mixture?

(2) What does Hering mean by 'local adaptation' and 'simultaneous light induction'?

(3) Who first formulated the laws of colour mixture?

EXPERIMENT II

§ 9. **The Distribution of Colour Sensitivity over the Retina: Campimetry.**— This experiment shows us that the retina of the eye is not uniformly sensitive to colour over its whole surface, but that there are three distinct zones or regions of sensitivity: an inner, efficient zone, over which we see all the primary colours (Hering's red, green, blue and yellow), and the intermediate colour qualities, besides blacks, whites and greys; a middle, partially colour-blind zone, over which we see only blues, yellows, blacks, whites and greys; and an outer, totally colour-blind zone, over which we see nothing but blacks, whites and greys.

MATERIALS.— Campimeter. [This is a sheet of stout grey cardboard, 70 cm. in length and 31.4 cm. in breadth. It is pierced towards one end by a circular opening, 1.4 cm. in diameter. This opening, placed at the centre of the breadth of the sheet, *i.e.*, having 15 cm. on either side of it, is 40.6 cm. distant from the farther, and 28 cm. distant from the nearer edge, in the longitudinal direction. The sheet is supported lengthwise

by two iron standards, with vertically adjustable clamps.] Colour mixer, with discs. Protractor. Small white fixation-point on strip of grey card. Eye-rest. Eye-shade. Grey screen. Mm. scale [either printed on the campimeter, upon the 40.6 cm. and one of the 15 cm. meridians, or ruled on a separate strip of paper].

PRELIMINARIES. — The colour mixer is laid horizontally on a table of convenient height for the experiment. The campimeter is adjusted over it in such a way that the circular opening lies directly above some portion of the area of the colour-disc. Care must be taken, of course, that only the disc (and not the central nut and washer) shows through the opening. The campimeter

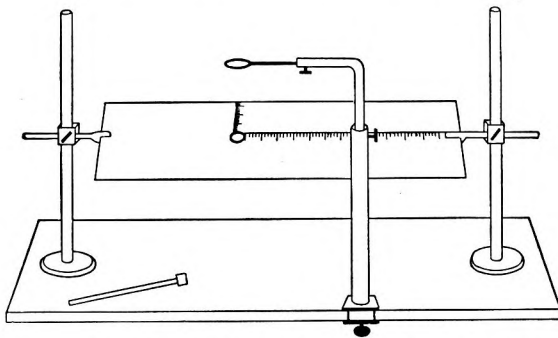

FIG. 4. — Campimeter, made by Chicago Lab. Supply Co., \$4.00.

must be set so high above the mixer that no shadow is cast by it upon the spot of colour seen through the circular opening. The eye-rest is now placed directly over this opening, at a height of 15 to 20 cm. above the campimeter.

During an experiment, *O* is to stand at the table, his observing eye pressing steadily on the eye-rest, and his weight supported principally upon his hands, which grasp the edge of the table (everted, slightly abducted, arm strongly extended at the wrist-joint). Eye-glasses, if worn, are to be removed. The eye-shade is carefully fitted over the eye which is not to be employed in the experiment. This eye should be kept open; but no light must be allowed to leak into it round the edges of the shade. In the intervals between experiments, the unshaded

eye should avoid extremes of brightness; *i.e.*, should not be turned towards a very bright window, or be held upon any very dark surface. It is well to hang a screen of grey cloth or cardboard on a near wall, fronting the seat which *O* takes in the periods of rest.

EXPERIMENT. — Let us suppose that *O* is to use his right eye, and to move this eye to the right: so that it is the temporal half of the observing retina which will receive the stimulation. The campimeter is arranged for comfortable observation; the longer of the two mm. scales extending to the right of *O*, parallel with the edge of the table.

(1) *E* places a red disc upon the mixer, and lays the white fixation-mark upon the mm. scale, at a distance of about 1 cm. from the centre of the circular opening. *O* settles his eye in the eye-rest, keeping it closed until the signal is given. When the "Now!" comes, he opens his eye, and fixates the white point. *E* at once begins to draw the mark steadily outwards, along the mm. scale: *O* follows the white point with his eye. The rate of movement must be learned by practice: it must neither be so slow that *O* grows tired in following the mark, nor so fast that his call to stop arrests it noticeably too late. When the mark has travelled a certain distance towards the edge of the campimeter, the red changes subjectively to a dull yellow. *O* calls out "There!" and at once closes his eye, bringing it back to its original position. *E* records the scale-mark at which the colour change took place. — The experiment is then resumed. At a second "Now!" *O* fixates the white point at its first position (1 cm. from the centre of the opening); *E* moves the mark out, very rapidly, to the place of change, — *O* following the movement as before; when this point is reached, *E* moves the mark steadily and evenly, at the old rate. Presently, all trace of colour disappears: the red is seen as a black or dark grey. *O* calls out "There!" and *E* notes the scale-mark.

When *O* is sufficiently rested, the experiment is repeated in the opposite direction: *i.e.*, *E* moves the point inwards, from right to left, and *O* at each "Now!" swings his eye quickly outwards to find the white spot. — *E* thus obtains four scale values. The average of the first and fourth gives the limit of

the efficient zone (horizontal meridian, temporal retina), and the average of the second and third gives the limit of the blue-yellow zone, for this particular *O* under these particular experimental conditions.

The same experiment may be tried, with a blue-green disc upon the mixer. The circular patch of colour, at first seen as bluish green, passes at a certain point upon the scale into blue, and at another, farther point, into grey. Incoming and outgoing determinations are made, as before, and the results noted.

The experiment may be repeated with as many combinations of the colour discs as the time allotted to campimetical work permits.

(2) Since the red disc of the first experiment passed over into yellow, before it became colourless, it follows that a red which contains no trace of orange in it, Hering's *Urroth*, will show no trace of colour in the blue-yellow zone, but will become grey or black at once when the limits of the innermost, efficient zone are transcended. *E* places on the mixer a mixed disc of red and blue. The fixation-mark is moved outwards. If *O* finds any trace of yellow in the disc, before it becomes colourless, *E* must add more blue to the red; if *O* finds any blue in it, *E* must decrease the amount of blue. After a few preliminary experiments, in which the right amount of blue is determined, a series of experiments is made, incoming and outgoing. Nothing will be seen but red and black or dark grey. This red-blue mixture is, then, the primary psychological Red.

Three similar series are made: one to find a green which passes into black, white or grey, without showing any trace of blue or yellow; another to find a yellow which remains unchanged until it becomes grey, *i.e.*, does not become a clearer yellow, or lose any trace of redness or greenness, as it crosses the boundary of the inner, efficient zone; and a third, to find a blue which also remains unchanged until it becomes grey, *i.e.*, which loses no trace of violet or greenish blue as it passes the boundary of the innermost zone. These are the three other psychological primaries: Hering's *Urgrün*, *Urgelb* and *Urblau*.

E notes the scale values of the points of subjective change, as

before, — two values for each colour. He also notes carefully the composition of the discs which correspond to the primary colours.

(3) If the illumination of the room remains constant during all the experimental series, and if the brightness-values of the primary red and green, and of the primary blue and yellow, are equal, then the limit of green-vision will coincide with the limit of red-vision on the campimeter, and the limit of blue-vision will similarly coincide with that of yellow-vision. Two colours are said to show 'equality of brightness-values' when they match, so far as brightness is concerned, the same grey (mixture of black and white); or, in other words, when they look 'equally bright' or 'equally dark.' It is not easy, without practice, to get a reliable brightness-equation between colours; it is difficult to abstract from the colour, and attend simply to the brightness-component in the impression. The experiment should, however, be made, as follows.

Find the primary red and primary green in preliminary experiments. Now place these two colours — the primary red and the primary green — upon two ordinary colour mixers. Stand the mixers before a neutral grey background. Note whether the colours appear equally bright, or whether the one appears brighter than the other. If the latter is the case (as will probably happen), add black to the brighter-looking or white to the darker-looking colour, or both, until the two compound discs show an equal brightness.

When *O* is fully satisfied that the two discs are equally bright, the campimeter experiments may be resumed. Mark the disappearance and reappearance of the red, outgoing and incoming. Then proceed at once to mark the disappearance and reappearance of the green. If the conditions have been favourable (illumination constant, match of colours good, *O* not too tired for accurate observation), the red and green zones (the two points averaged from the four scale values) will coincide.

A similar experiment should be made with the primary blue and yellow.

RESULTS. — *E* has a series of measurements from the first set of experiments; a similar series, and composition formulæ, from

the second; and formulæ for the brightness-match of the primaries, and campimetical determinations, from the third. All these data should be entered in the note-book.

If time allows, all three sets of experiments should be repeated, at least upon the remaining three principal meridians of the retina. Thus, if the campimeter be turned through 180° , the longer of the two mm. scales will lie to the left of O , and the nasal half of his right retina will receive the stimulation of the colour patch. If it be turned through 90° , so that the shorter mm. scale extends towards or away from O , the lower or upper half of the retina can be worked over. Intermediate positions of the scales correspond to intermediate retinal meridians. As a result of a full series of experiments, maps of the zones for the two eyes may be prepared, by means of coloured crayons, and inserted in the note-book.

The following Questions arise.

E (1) In exp. (1) we determined the boundary of the innermost, efficient zone: we took the average of the scale values at which red passed over into dull yellow, and *vice versa*. In exp. (2) we made a similar determination: we noted the point at which the primary red passed over into grey. The two boundaries do not, however, coincide; the first lies farther out upon the campimeter than the second. Why should this be the case?

E (2) What advantages has this campimeter over one in which the fixation-point should be kept constant, and the coloured stimulus moved to and fro? What are its disadvantages?

O (3) Are we aware of the existence of the three colour-zones in everyday life? Make a rough test, by fixating some point on the wall of a furnished room. How do you account for the fact thus brought out?

E and *O* (4) Does the arrangement of visual sensations on the retina suggest anything to you as regards the probable course of development of those sensations? Is the suggestion confirmed by what you know of the facts of colour blindness (partial and total)?

EXPERIMENT III

§ 10. **The Phenomena of Visual Contrast.**—Every patch of brightness or colour in the field of vision is affected by the simultaneous presence of all the other patches, and affects them in its turn, in certain quite definite ways. This reciprocal induction of brightnesses and colours is termed *contrast*. The chief laws of contrast are as follows. (1) The contrast-effect is always in the direction of greatest qualitative opposition. (2) The more saturated the inducing colour, the greater is the contrast-effect. (3) The nearer together the contrasting surfaces, the greater is the contrast-effect. (4) Colour contrast is at its maximum when brightness contrast is eliminated. (5) The contrast-effect is enhanced by the elimination of contours.—In the present experiment, we shall verify these five laws.

A. The contrast-effect is always in the direction of greatest opposition.—This law says that the contrast-effect of a white will always be in the direction of black, that of a black in the direction of white, and that of any colour in the direction of its antagonistic (complementary) colour. We will first of all establish the truth of the law in a general way.

MATERIALS.—Black velvet. Black paper (paper which, as compared with the black of the velvet, is a dark grey). White card. Pins.—Coloured papers. Grey papers. White tissue paper. Scissors.

EXPERIMENT (1). *Brightness contrast.*—Cut out from the 'black' paper a parallelogram 2 cm. in breadth and 10 cm. in height. From the centre of this, cut out a piece 12 mm. wide and 8 cm. long. There remain two strips, 4 mm. wide, connected by cross pieces at their two ends. Fold the end pieces upon themselves, for stiffness, and fix the strips vertically upon the background of velvet by two pins thrust through the doubled ends. Do not push the strips close up to the background, but leave them about 1 mm. from it.—Precisely in the centre of the velvet area enclosed by the strips place a pin-head, to serve as fixation-point.

O fixates this point steadily. *E* moves in, from the side, a piece of white card, 7.5 cm. high, and as long as is convenient

for holding, keeping its incoming edge precisely parallel to the vertical 'black' strips. The card is pushed in under the strip, until it hits against the pin-head in the centre of the figure. *O*, keeping his eyes always upon this pin-head, describes the appearance of the two 'black' strips at the moment when the white card emerges from under the strip on *E*'s side of the background.

(2) *Colour contrast*. — Cut pieces of coloured paper, 10×7.5 cm. Cut, further, strips of grey paper, 2×1.5 cm. Match the two sets, roughly, paper for paper, as regards brightness; so that every colour shall have a grey that is, at least approximately, of the same brightness as itself.

E lays a matched grey upon a coloured piece, and covers the two with tissue paper. *O* describes the appearance of the grey as seen through the white tissue. This is repeated, until the whole series has been worked through.

We proceed now to a more exact verification of the law, as illustrated by the induction of a grey by a surrounding colour.

MATERIALS. — Two colour mixers and discs, the latter 11 cm. in diameter. Rings of black and white paper, 12 mm. in breadth, and 7.5 cm. in (outside) diameter. Protractor. Grey screens.

PRELIMINARIES. — Select one of the most saturated colour discs: say the standard red of the series. Place it upon a colour mixer, before a grey background. Choose a grey screen that is *approximately* of the same brightness as the red.

Paste (or pin) a white ring upon the red disc, centring it as accurately as possible. The ring is much lighter than its red background. Paste (or pin) sectors from a black ring over a portion of the white, and set the mixer in rotation. The black and white mix to give a grey ring; but the grey is, in the present case, tinged with the contrast colour. Is this contrast colour lighter or darker than the red background, or is it of the same brightness? In either of the two former cases, add or subtract black, until the whole disc (red and contrast ring) is of the same brightness throughout. — We now have an uniformly bright contrast disc, seen against a grey screen which itself is of approximately the same brightness as the disc.

The problem is, to produce on the other colour mixer a colour which shall be the exact match, in colour tone and brightness, of the colour of the contrast ring. Noting the composition of this second disc, we shall have an objective expression of the contrast-effect. We shall be able to say that, under the conditions of our experiment, the red disc turns a grey ring, composed of x degrees of white and y degrees of black, into a verdigris which is matched by a mixture of p degrees of blue, q degrees of green, r of white and s of black.

EXPERIMENT (3). — O sits directly opposite the two mixers, at such a distance that the contrast ring shows an *uniform* contrast colour, *i.e.*, is equally coloured all over. E sets up the second mixer by the side of the first, before the same screen, and places on it either three discs (contrast colour, black and white) or—if the contrast colour (as is probable) cannot be exactly matched from any of the papers—four discs (the two which, when mixed, give the contrast colour, and black and white). These three or four discs are varied, until O declares that the contrast ring and the mixture on the second mixer are exactly alike in every respect. O must make his judgments quickly, and with steady fixation; otherwise after-images will arise, and disturb the experiment. The changing of sectors on the second mixer should be carried out methodically, as in Exp. I.

This experiment is to be repeated with the standard orange, yellow, green, blue and violet of the coloured paper series.

B. The more saturated the inducing colour, the greater is the contrast-effect. — This law can be verified by a modification of the experiment just performed.

PRELIMINARIES. — E has the contrast discs (coloured discs with black and white rings) of the preceding test. He takes one of these, *e.g.*, the red, and fits it together with a black and a white disc. Let us suppose that 20° of white and 40° of black are added to 300° of the red. On rotation, the disc shows, of course, a less saturated red. Equality of brightness between this less saturated red and the grey ring must be maintained by keeping the same proportions of black and white in the exposed part (300°) of the original ring as were used for the full ring of

the previous experiment. — The grey screen must be changed, to match the brightness of the changed disc.

All our previous conditions — equality of brightness in background, disc and ring — are now realised, only that they are realised for a different saturation of the inducing colour. The problem is, to match the colour of the ring, both in colour tone and in brightness, by a mixture of verdigris, black and white on the second colour mixer.

EXPERIMENT (4). — The experiment is carried out in the same way as before. When O has matched the contrast colour induced by $300^\circ R$, $20^\circ W$ and $40^\circ B$, other inducing mixtures are taken: *e.g.*, —

$$\begin{aligned} 240^\circ R + 40^\circ W + 80^\circ B, \\ 180^\circ R + 60^\circ W + 120^\circ B, \\ 120^\circ R + 80^\circ W + 160^\circ B, \\ 60^\circ R + 100^\circ W + 200^\circ B, \\ 30^\circ R + 110^\circ W + 220^\circ B. \end{aligned}$$

The results of these comparisons give us an objective expression of the decrease of contrast-effect with decrease of saturation of the inducing colour.

When the red series is concluded, other series may be taken (whether with the same or with different intermixtures of black and white sectors) with orange, yellow, green, blue and violet.

C. The nearer together the contrasting surfaces, the greater is the contrast-effect. — The evidence of this law is given by experiments upon *marginal* contrast. It is found that, when two contrasting surfaces are apposed, there is a margin of pronounced contrast-effect, beyond which the contrast gradually diminishes, until with increasing distance it becomes unnoticeable.

We can demonstrate marginal contrast, and determine its saturation, by an experiment of the same kind as the two preceding.

PRELIMINARIES. — *E* makes up a disc of black and white sectors, 11 cm. in diameter, to match one of the standard coloured discs (say, the red) in brightness. Over the mixture is laid a smaller disc, 5.5 cm. in diameter, of the corresponding colour

(red). When this mixture is rotated, *O* will see a ring of contrast colour surrounding the smaller disc; the ring appears to extend (under favourable conditions) for about 6 mm. into the grey, but is very distinctly most saturated at the line of junction of the grey with the colour (red).

EXPERIMENT (5). — The disc just described is set up in front of an appropriate grey screen. By its side is mounted, on the second mixer, a mixture of the complementary colour (verdigris, black and white). The problem is, to match the complementary mixture with the most saturated line (marginal line) of the contrast band upon the original disc. The match must be made exact, both in colour-tone and in brightness.

The experiment should be repeated with each of the standard colours of the series.

D. Colour contrast is at its maximum when there is no simultaneous brightness contrast between the two surfaces. — In all the preceding experiments, we have taken great care to avoid brightness contrast. The reason is, that the presence of such contrast would have seriously impaired the saturation of our contrast colour. This law may be verified as follows.

PRELIMINARIES. — *E* selects one of the prepared (ringed) discs of experiment (3), and cuts a number of black and white ring-sectors for pasting (or pinning) to it. Thus, if the ring consists of 120° white and 240° black, he cuts sectors of 30° white (so that he can increase the white of the ring to 150° , 180° , 210° , 240° , 270° , 300° , 330°) and of 30° black (so that he can increase the black to 270° , 300° , 330°).

EXPERIMENT (6). — The contrast disc, with an extra 30° of white or black in its ring, is set up before its appropriate background. The contrast colour is matched upon the second mixer, as before. Note that the same grey background must be retained for the second mixer, in order that the contrast relations may remain the same on both discs.

Repeat the experiment with another 30° of white or black in the ring; and so on, till both series are concluded.

Repeat the whole experiment for all the standard colours of the series, *i.e.*, for all the ringed discs of experiment (3).

E. The contrast-effect is enhanced by the elimination of contours. — The elimination of contours, *i.e.*, of the lines of demarcation between the inducing and the induced papers, has been secured to a large extent in the preceding experiments by the use of rotating discs. The colour mixer is useful, on the one hand, because it allows us to produce any colour that we need by putting together a number of constituent colours; without it, we should be at a loss for exact matches and fine gradations of tint and saturation. But it is useful, on the other hand, because of its efficacy in eliminating boundary lines and other irrelevant features that might distract the attention. The grain of the paper is obliterated by rotation; small flecks and irregularities of texture are smoothed over; there is no 'edge' to be seen, where the small disc borders on the large; we have a single surface, uniformly illuminated.

The dependence of the contrast-effect upon the elimination of contours may be shown as follows.

PRELIMINARIES. — *E* selects a grey paper which has the same brightness (approximately) as one of the standard coloured papers: *e.g.*, the grey paper that has served as background, in previous experiments, for the standard red. From this paper a contrast ring is cut, and pasted (or pinned) upon the red disc.

EXPERIMENT (7). — The red and grey disc is mounted on the mixer, before its background. The mixer is *not* set in rotation. The problem is, to match upon the second colour mixer, placed beside the first and before the same background, the contrast colour of the stationary grey ring.

When this match has been made, the experiment is repeated, only that this time the first mixer is rotated. The sole difference introduced by rotation is the elimination of the edges of the grey ring. — Notice the enhanced saturation of the contrast colour in the second case.

We can, however, improve even upon the rotating discs. And we can show, by a modification of exp. (2), that the elimination of contours will enhance the contrast-effect, even if it involve a diminution of the saturation of the inducing colour: a factor which exp. (4) proved to be of prime importance for contrast.

PRELIMINARIES. — *E* cuts a number of discs, 10 cm. in diameter, from white tissue paper. When one of these discs is laid over one of the ringed discs of experiment (3), and the whole rotated, we have a contrast disc of lessened saturation, but of an ideal uniformity as regards contours.

EXPERIMENT (8). — Experiment (3) is repeated, except that the tissue-covered discs are set upon the first mixer. Working through the full set of standard colours, we get a number of contrast matches which we can compare with those of the original experiment. The grey backgrounds must be regulated to match the discs.

At the end of the experiment, it is well to set up, on the first mixer, a given contrast match from experiment (3), and on the second the corresponding match of experiment (8), and so to assure oneself of the greater saturation of the latter. The two may be shown to *O*, simultaneously, without any information as to which is which; and he may be asked to decide which is the better colour. Suitable backgrounds must, again, be chosen.

RESULTS. — *E* has the results of *O*'s introspections, thrown for the most part into tabular form. All notes regarding change of objective illumination during the experiments, disturbance by after-images, by a definite expectation on *O*'s part, by flicker of the discs, by slipping of fixation, etc., must be carefully kept.

The following Questions arise.

E and *O* (1) Does contrast arise gradually, or is it given at once with the presence of the inducing colour?

E and *O* (2) We have been working with a grey and a colour. What would happen if we worked with two colours?

E and *O* (3) Can you suggest any way of obtaining contrast-effects from surfaces that are even more uniform, and show even less contour, than the tissue-covered discs?

Answers to the following must be obtained from the literature:

E and *O* (4) What is the precise difference between the contrast-theories of Helmholtz and Hering?

E and *O* (5) By what experimental steps did Hering disprove the Helmholtz theory?

EXPERIMENT IV

§ 11. **Visual After-images:** (1) *Negative.*—If we are exposed, for some length of time, to visual stimuli of approximate constancy, our eyes become ‘adapted’ to their surroundings; we ‘grow used’ to the particular visual environment. The law of this adaptation is that all brightnesses tend towards a middle grey, and all colours towards neutrality.

PRELIMINARY EXERCISES.—(1) After working in ordinary daylight, shut yourself in the dark room. What is the immediate effect? How does it change with time? (2) When you have ‘grown used’ to the darkness, pass out of the dark room into a light (if possible, a sunny) room. What is the immediate effect? How does it change with time? (3) Turn on the gas, or light an oil-lamp, in a curtained room. What is the colour of the illumination? Does it persist? (4) Hold a bright coloured glass (preferably from the region yellow to blue-green) before the eyes, wrapping a black cloth around the hands for the exclusion of lateral light, and look through it at the landscape. What is the immediate effect? Does it persist, say, for five minutes?

In these exercises, the adaptation has been ‘general,’ extending over the whole of the visual field. The same phenomena are observed if the stimuli are ‘local.’

(5) Lay a sheet of baryta (or other dead-finish white) paper and a piece of dead-black velvet side by side. Fixate steadily a point upon the line of junction of the two surfaces. What do you see? (6) Take a dark grey and a light grey paper, and lay them together. Fixate as before. (7) Try with any two coloured papers. What is the effect of the steady fixation upon their colour and brightness? (8) Lay a small coloured disc upon an extended background of any quality. Fixate the disc steadily. What happens?

Adaptation, whether general or local, has its after-effects. If we pass from lamp-light into a dark room, our eye is blue-sighted. Adaptation to the yellow of the lamp-light means that ‘real’ yellows tend towards grey, and that all other light has a tinge of the complementary blue. If we pass from daylight into darkness,

our eye is somewhat green-sighted. The light that penetrates to the retina through the sclerotic is reddish; we therefore become adapted to red; and this means that 'real' reds tend towards grey, and that all other light has a tinge of the complementary verdigris. If we pass, again, from light to dark, our eye is dark-sighted. We have become adapted to the light; *i.e.*, all lights tend towards a middle grey, and the darkness into which we enter has a tinge of the antagonistic black. It should be noted that the shift of brightnesses by adaptation is, apparently, less radical than the shift of colours. A colour is readily brought to disappearance; but brightnesses fall short of the middle grey. When we wake in a darkened room after a night's sleep, the room is distinctly grey, and not black; but the grey does not lie half-way between black and white.

These after-effects of general adaptation have no specific name. The after-effects of local adaptation are known as 'negative after-images.'

The chief laws of the negative after-image are as follows. (1) The colour or brightness of the image is always antagonistic to the colour or brightness of the stimulus. (2) A contrast colour in the stimulus is effective in the after-image. (3) The interaction and reciprocal influence of differently stimulated parts of the retina persist in the after-image. (4) The after-image is intermittent or periodic, not continuous. (5) The intensity and duration of the after-image are a function of the intensity (relative and absolute) and duration of the stimulus, and of the intensity (relative and absolute) of the reacting light.

MATERIALS. — Black velvet; black cloth; dead-finish black and white cardboard or paper. Scissors. Compasses. Thumb-tacks. Standing desk, or table desk. Small pins.

EXPERIMENT (1). — Lay the black velvet evenly on the desk. Cut a disc of white paper, 1 cm. in diameter, and mark its centre by an ink dot. Lay it on the centre of the velvet.

O fixates the ink dot steadily, for 15 to 60 sec. He then closes his eyes, and places his hands over the closed lids. *E* lays the black cloth over his face.

O describes the appearance and course of the after-image in the darkened field of vision.

EXPERIMENT (2). — Lay the white cardboard on the desk. Pin to its centre a strip of black paper, 2 cm. long by 4 mm. broad.

O fixates the pin-head, and observes the after-image, as before.

EXPERIMENT (3). — Arrange the materials as in (1). Drive a pin into the velvet, so that its head lies exactly under the ink dot at the centre of the white disc.

O fixates the ink dot as before. When the time of stimulation has elapsed, he blows away the white disc, and fixates the pin-head. The after-image develops upon the velvet surface.

EXPERIMENT (4). — Lay the white cardboard on the desk. Drive a pin into its centre. Directly over the pin-head lay the black strip used in (2). The pin-hole serves as fixation-mark.

O fixates the pin-hole. At the end of the time of stimulation, he blows away the strip, and fixates the pin-head. The after-image develops upon the white surface.

EXPERIMENT (5). — Tack a sheet of white cardboard to the desk. Lay over it the black velvet and the white disc.

O fixates the ink dot on the disc. At the right time, *E* draws away the velvet and disc, and *O* fixates the pin-hole left in the white card by (4). The after-image develops on the white surface.

A better variation of this experiment is as follows. Tack the white cardboard to the desk. Lay the two halves of a sheet of black cardboard over the white, leaving a strip of white, 1 cm. broad, at the centre. *O* fixates the pin-hole at the centre of the strip. At the right time, *E* draws away the two black pieces, and the after-image of the strip develops on the white ground.

EXPERIMENT (6). — Tack the black velvet to the desk, and drive a pin through its centre. Lay over this the white cardboard and the black strip.

O fixates the pin-hole. At the right time, *E* withdraws the white card and strip, and *O* fixates the pin-head. The after-image develops on the black surface.

A better variation is as follows. Tack the black velvet to the desk, and place the pin as before. Lay the two halves of a sheet of white cardboard over the black, leaving a strip of black, 1 cm. broad, at the centre. *O* fixates the pin-head. At the right time, *E* draws away the two white pieces, and the after-image of the strip develops on the black ground.

These six experiments show the fundamental phenomena of the negative after-image, as seen in the fields of the closed and open eyes. We may now proceed to verify the first law in the case of colours.

MATERIALS.—An upright wooden frame, grooved in front to take a half-sheet of cardboard (*i.e.*, a piece 55 by 35 cm.). Cardboard. Coloured paper discs, 2.5 cm. in diameter. Pins. [The frame must be screwed or clamped solidly to the table. To the back is tacked a half-sheet of light-grey cardboard, or of cardboard covered with light-grey paper. An ink dot is made at the centre of the card. The grooving on the front of the screen is so made that another half-sheet of grey card can be slipped in and out from the side, not from above. A paper disc is pinned to the centre of this second card.]

EXPERIMENT (7).—The frame is set up on a table, in moderate diffuse daylight. *O* seats himself at a convenient distance before it. *E* slips in the front grey card, and pins to its centre one of the coloured discs. *O* fixates the pin-head steadily for some 30 sec. *E* then quickly withdraws the card and disc; *O* fixates the ink dot on the second grey card, and reports the course of the after-image.

The experiment is repeated with at least six papers (R, Y, O, G, B, V).

The experiment may be varied by the projection of the coloured after-image upon variously coloured backgrounds.

MATERIALS.—Coloured surfaces, marked at the centre with an ink dot, to replace the grey projection-screen of exp. (7). Other materials as before.

EXPERIMENT (8).—*O* projects the after-images of the six discs upon each of the six backgrounds, R, O, Y, G, B, V. The changes in the appearance of the after-image are to be reported and explained.

We have now verified our first law. Incidentally, other laws have been exemplified.

Question (1) Have any of the foregoing experiments shown that a contrast colour in the stimulus is effective in the after-image? Have any of them shown that contrast is enhanced in

the after-image? Can you devise a 'pure' experiment to demonstrate the law?

(2) Have any of the foregoing experiments shown that the reciprocal action of the differently stimulated parts of the retina is continued in the after-image? Can you devise a modification of any one of them which shall give a striking demonstration of the law?

(3) Have you made any observations which tend to prove that the after-image is discontinuous in its course? Are there any possible factors in the experiments that might lead you to regard the image as intermittent, when in reality it is continuous?

The fifth law may be verified as follows.

MATERIALS. — Dark asbestos-lined box, containing a Welsbach gas-burner, and carrying a tube and condensing lens. Black screen, with circular opening, 3 cm. in diameter, at the centre of a square frame, 15 by 15 cm. Ground glass, to fit into the frame, marked at the centre with an ink dot. Coloured gelatine sheets.

Dark box, asbestos-lined, open in front, containing a second Welsbach burner. Ground glass, to fit the front of the box.

Black cardboard screens. Rubber gas-tubing. Two cocks. Head-rest. Metronome.

PRELIMINARIES. — The apparatus must be set up in the dark room, preferably upon a long black table. *O* sits at one end of the table, his head secured in the head-rest. At a distance of some 1.5 m. stands the large black screen, extending across the table; the centre of the circular opening should lie a little below the level of *O*'s eyes. The required gelatines and the ground glass are placed in the frame, the glass (rough side outwards) towards *O*. Behind the screen stands the first dark box; the cock that governs the gas-supply is screwed to the table, just outside of the box.

A smaller table stands by the side of the larger, a little nearer *O* than the large screen. On this is placed the second dark box, its ground glass fronting obliquely upon the ground glass of the screen. The cock that governs the gas-supply to the second burner is screwed upon the table, just outside of the box.

E sits beside the first box, in the angle made by the tables. The two cocks must be within easy reach of his two hands. The cardboard screens are set up along the edge of the large table, to shield *O* from the light of the second burner.

The cocks are so arranged that a turn of the handle raises the flame from bare existence to the intensity needed for the experiments. The stimulus-flame should be fairly high; the second light must have a much lower intensity.

EXPERIMENT (9). — *O* sits for 15 min. in the dark room, that his eyes may be properly 'adapted.' *E* arranges the apparatus: sets up the side screens, lights the burners (turning the flame down to its lowest intensity), etc.

O settles his head in the head-rest, covers one eye, and looks towards the screen. *E* starts the metronome. Two seconds after a "Now!" he turns up the stimulus-burner, and *O* fixates monocularly the centre of the coloured circle.

After a certain number of seconds has elapsed, *E* turns the stimulus-burner down and the second burner up, simultaneously. *O* fixates the ink dot on the ground glass of the dimly lighted screen, and describes the appearance and course of the after-image.

It will probably be necessary to take, say, ten preliminary experiments, for the sake of practice. These may be made with a 20 sec. exposure of the stimulus. In the formal series, ten experiments should be made upon each eye with each of the exposures

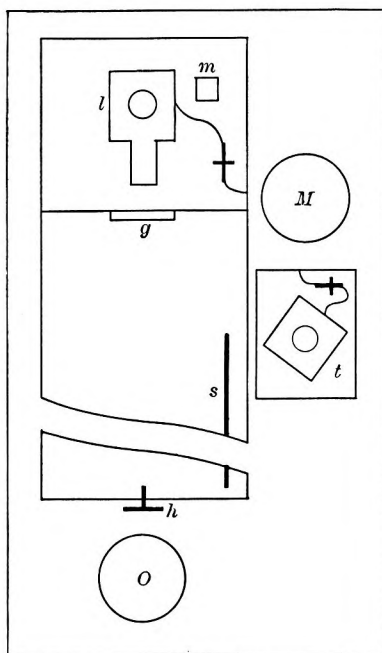

FIG. 5. — Apparatus for the observation of negative after-images. *O*, observer's chair; *h*, head-rest; *s*, screen; *g*, ground-glass window; *l*, lantern; *m*, metronome; *M*, manipulator's chair; *t*, second table with dark box, etc.

5 sec., 10 sec., 20 sec., 30 sec., 45 sec., and 60 sec., the times being taken in irregular order. Every phase of the after-image should be reported by *O*, and jotted down by *E*, who also records (by counting the metronome strokes) the time of its appearance.

So far, we have kept the intensity of the stimulus and of the reacting light constant, and have simply varied the duration of the stimulus. It is clearly possible, by varying the height of the two Welsbach flames, to vary the intensity of the stimulus and the intensity of the reacting light within fairly wide limits. Experiments may be made, under these changed conditions, as time allows.

RESULTS. — *E* has the record of *O*'s introspections, which in exp. (9) are given a tabular form.

Question (4) Explain these results according to the theory (*a*) of Helmholtz and (*b*) of Hering. Which theory is the more adequate?

(5) What are the parts played by adaptation and its apparent opposite, contrast, in the general economy of vision?

(2) *Positive After-images.* — We have already found cases in which the negative after-image is preceded by an image which repeats the characteristics of the stimulus, instead of reversing them. This image — a simple recurrence of the primary sensation, with diminished brightness and less saturated colour — is termed the positive after-image. It follows the disappearance of the primary sensation at a brief but distinctly noticeable interval; and it is itself separated from the negative after-image by a somewhat longer period. It has two chief conditions: a relatively intensive stimulus, of very short duration.

EXPERIMENT (10). — Seat yourself before a brightly illuminated window, which is partially covered by a shade, and through which a gate, trellis-work, shrubs, etc., can be seen. Secure the head in a head-rest, and fixate the window. Cover the eyes with the hands, and keep them covered, until there is no trace of an after-image in the dark field: maintain the original fixation as nearly as you can. When the field is clear, draw the hands rapidly aside, without any jar of head or eyes, and bring them as rapidly together again. What do you see in the dark field?

EXPERIMENT (11).—Turn an electric light, or a gas flame, quickly on and off in the dark room. Keep the eyes steadily directed, in the darkness, to the bulb or burner. What do you see?

If the duration of the stimulus be more than minimal, or its intensity unusually great, we have the conditions for the arousal of a negative as well as of a positive after-image. Whether the one or the other appear, depends primarily upon the character of the reacting light.

EXPERIMENT (12).—Glance for a moment at the setting sun. Project the after-image alternately upon the ground at your feet, and upon the dark field of the closed eyes. What do you see?

EXPERIMENT (13).—Fixate the window of exp. (10) for some 5 sec., and project the after-image alternately upon a white wall and upon the field of the closed eyes. What do you see?—Explain the changes in the after-image of these two experiments.

The interval which elapses between the disappearance of the primary sensation and the appearance of the positive after-image is filled, under certain circumstances, by a *positive and complementary* after-image.

EXPERIMENT (14).—*O* sits for 10 min. in the dark room. *E* then moves slowly to and fro, across the black field, a wire the point of which has been heated to red heat, or an incense-stick the point of which is steadily glowing. What is seen? How is it to be explained?

We have had occasion to notice, in experiments upon the negative after-image, that a colourless stimulus may have coloured after-effects. The same phenomenon may be observed in the positive after-images of white stimuli: as the after-image rings off, it passes through well-defined colour-stages, the 'flight of colours.'

EXPERIMENT (15).—*O* sits for 5 min. in the dark (or in a darkened) room. *E* so arranges a screen or curtain over the window that the two upper panes can be exposed for the required time.

At a "Now!" *O* looks towards the window. *E* removes the screen, and *O* fixates the vertical bar separating the panes. After 20 sec., *E* covers the window; *O* closes his eyes, and reports the course of the after-image in the dark field.

The experiments must be continued until the flight of colours is constant from trial to trial.

Question (6) How is the flight of colours affected by the varying brightness of the sky?

(7) How is it affected by change in the duration of stimulus?

(8) What explanation of the phenomenon can you offer?

(3) *Binocular After-images*. — We observe, under favourable conditions, that stimulation of the one eye produces an effect in the field of the other, unstimulated eye, which has all the characteristics of a true after-image.

EXPERIMENT (16). — Lay a disc of bright red paper, 1 cm. in diameter, upon a white field. Close and cover the eyes, until there is no trace of after-images in the dark field. Open the right eye, and fixate the red stimulus for 5 sec. Then close and cover the right eye; blow away the red disc, and fixate an ink dot upon the white field with the left eye. What do you see? How is it to be explained?

CHAPTER II

AUDITORY SENSATION

§ 12. **Auditory Sensation.** — There are two classes of auditory sensations: simple *tones* and simple *noises*. Simple tones (1) are given by weakly sounding tuning-forks, standing upon their appropriate resonance boxes, and by weakly blown bottles; (2) occur subjectively, as ‘singing in the ear’; and (3) can be heard (as difference tones or partial tones) in compound tones or *clangs*. Moreover, (4) all tones which lie near the upper limit of musical hearing, whatever their source, are heard as simple tones. Instances of simple (or approximately simple) noises are the pop of a soap-bubble, the snap of the electric spark, the thud of a leaden ball falling on a leaden block, etc.

The external stimulus of hearing is the vibration of some physical body, which is conveyed to the ear, under ordinary conditions, by a wave-motion of the air,—a rapid to-and-fro movement of the air particles in the direction in which the wave travels (longitudinal vibration). When the wave-motion, or system of wave-motions, is incomplete, rudimentary, we hear a noise; when it reaches a certain number of complete vibrations, a tone. Physically regarded, therefore, a noise is an imperfect tone; and it is probable that noise is the earliest form of auditory sensation in the history of the race. Psychologically, tone and noise are quite distinct, different kinds of sensation.

The series of tones forms a one-dimensional manifold, within which we may pass, without break, from sensation quality to sensation quality. It thus resembles the black-white series in visual sensation. There are no names for tones corresponding to ‘black,’ ‘green,’ etc., in the sphere of vision. Tones are named, absolutely, by conventional musical symbols (*C*, *#f*, *g³*), or by their pitch numbers, the number of vibrations which the particles of the sounding body perform in a second of time (thus

the *C* makes 66 total or double vibrations in the 1 sec.). They are named, relatively, by the names of the musical 'intervals.' Thus *C* and *E*, c^1 and e^1 , form a 'major third'; c^2 and d^2 a 'major second'; and so forth.

The following Table shows the pitch numbers of the tones in the scale of *c*-major, on the assumption that the a^1 has the pitch number 440. The names of the various octaves, and the letter-symbols of their notes, are also given.

	<i>C</i>	<i>D</i>	<i>E</i>	<i>F</i>	<i>G</i>	<i>A</i>	<i>B</i>	
Subcontra octave . . .	$16\frac{1}{2}$	$18\frac{9}{16}$	$20\frac{5}{8}$	22	$24\frac{3}{4}$	$27\frac{1}{2}$	$30\frac{1}{8}$	C_2-B_2
Contra octave . . .	33	$37\frac{1}{8}$	$41\frac{1}{4}$	44	$49\frac{1}{2}$	55	$61\frac{7}{8}$	C_1-B_1
Great octave	66	$74\frac{1}{4}$	$82\frac{1}{2}$	88	99	110	$123\frac{3}{4}$	<i>C-B</i>
Small octave	132	$148\frac{1}{2}$	165	176	198	220	$247\frac{1}{2}$	<i>c-b</i>
Once-accented octave .	264	297	330	352	396	440	495	c^1-b^1
Twice-accented octave	528	594	660	704	792	880	990	c^2-b^2
Thrice-accented octave	1056	1188	1320	1408	1584	1760	1980	c^3-b^3
Four-accented octave .	2112	2376	2640	2816	3168	3520	3960	c^4-b^4
Five-accented octave .	4224	4752	5280	5632	6336	7040	7920	c^5-b^5
Six-accented octave .	8448	9504	10560	11264	12672	14080	15840	c^6-b^6
Seven-accented octave	16896	19008	21120					c^7

The notes of the accented octaves are sometimes printed, less conveniently, as c' , c'' , c''' , etc.

The vibration ratios of the principal musical intervals are:

Octave	$c-c$	1:2	Major Second . . .	$c-d$	8:9
Fifth	$c-g$	2:3	Minor Second . . .	$c-\flat d$	15:16
Fourth	$c-f$	3:4	Major Seventh . . .	$c-b$	8:15
Major Third	$c-e$	4:5	Minor Seventh . . .	$c-\flat b$	9:16
Minor Third	$c-\flat e$	5:6	[Natural (subminor) Seventh 4:7]		
Major Sixth	$c-a$	3:5	Tritone	$f-\flat$	32:45
Minor Sixth	$c-\flat a$	5:8			

In actual experience, pure tones and pure noises are very rare. The ripple of a brook, the roar of city traffic, contain tones; and musical 'tones' are accompanied by noises, the violin tone, *e.g.*, by a rough scrape, the piano tone by a thud. Nor is this the only form of intermixture. The tonal part of the violin 'tone' is not a pure sensation of tone, but a medley

of tones: all musical instruments furnish compound tones, or clangs, not simple tones. And ordinary noises — hiss, crash, buzz, clatter, etc. — are made up of a number of simple noises given together and in succession.

PRELIMINARY EXERCISES. — The following exercises will serve to make clear the relation of the tone-stimulus to the noise-stimulus, and the introspective difference between the two sensation classes. They should be performed by both *O* and *E*.

(1) Take a book with a ribbed-cloth binding. Tap the cover with the finger-nail; or pass the nail slowly across two or three ridges. You hear a tapping or plucking or snapping noise. Draw the nail more quickly over a number of ridges. The noise is replaced by a harsh scroop which is distinctly tonal. The pitch (quality) of the tonal element rises as the movement becomes quicker. Notice that the pluck and the scroop are entirely different sense-experiences, although from the physical standpoint the latter is only a series of plucks.

(2) The 'imperfection' of the system of wave-motions which characterises the noise-stimulus may be produced by the *interference* of a number of complete wave-motions (tonal stimuli).

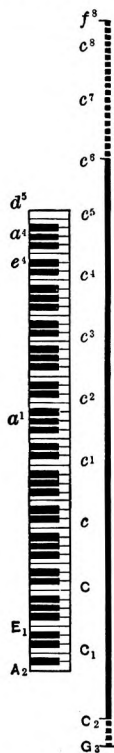

FIG. 6. — The series of auditory qualities. The keyboard of a grand piano extends from the A_2 of $27\frac{1}{2}$ vs. to the c^5 of 4224 vs. The smaller piano keyboard ranges between the C_1 of 33 vs. and the a^4 of 3520 vs. Helmholtz' lower limit of orchestral music is the E_1 of $41\frac{1}{4}$ vs. (German 4-stringed double bass); his higher limit, the a^5 of 4752 vs. (piccolo flute). The organ has a range of 9 octaves: C_2 ($16\frac{1}{2}$ vs.) to e^6 (8448 vs.). The highest note of the violin is the a^4 (2640 vs.). The range of audition is, approximately, from the G_3 of $12\frac{3}{8}$ vs. to the f^8 of 45056 vs. — See Ellis, in Helmholtz' "Sensations of Tone," 1895, 17 f.

Thus we can get a noise by pressing down simultaneously a number of adjacent keys upon the piano keyboard. Take wooden blocks of the right lengths, and press down two, three, four, etc., notes simultaneously. Give a sharp, clean pressure, and listen for the immediate result: do not wait for the after-resonance before making up your mind whether you hear a clang or a noise. In the middle region of the scale you must press down, probably, two or three full octaves; in the lower region the sounding of a single octave will generally produce mere noise. The experiment is easy for some observers, difficult for others. If the crash of the keys remains obstinately tonal, compare it with the noise produced by striking the wooden block upon the side or top of a radiator, or upon the bottom of a metal tray. The noises are very similar; and the comparison helps to bring out the essentially noisy character of the complex piano sound.

We see, therefore, that a frequent recurrence of noise-stimuli may give a tonal effect, and that the interference of a number of tonal stimuli may give a noise effect.

(3) To demonstrate the presence of tones in sound-complexes that pass for 'noises' in ordinary parlance, press down the loud pedal of the piano (carefully, so that the movement of the damper-heads does not set the strings in vibration), and clear the throat, or say 'Brrr-r-r-r' before the instrument. Notice the resonance. By careful observation it will be possible not only to localise the region of greatest resonance, but to determine the particular note which rings loudest in the mass of sound.

(4) Observe a number of tones (or clangs) and noises. Use all the sources of musical sound that the laboratory possesses: strike a note in the upper, lower and middle regions of the piano scale, blow a Quincke tube, strike a tuning-fork, etc. Similarly, get as many noises as possible: taps, thuds, crashes, etc. Write out a careful introspective account of tone and noise. Are there any constant characteristics of the tones, which the noises do not possess, and *vice versa*? Are there any common attributes? Do noises, *e.g.*, show qualitative differences, pitch-differences, akin to those of tones? Make your description as full and complete as possible.

QUESTIONS UPON AUDITORY SENSATION.—(1) Define the terms: pitch, pitch-number, quality (two meanings); tone, compound tone, clang, chord, interval; overtone, undertone, partial tone, upper partial tone, harmonic, fundamental, root-tone, prime; vibration, single vibration, vibration-ratio.

(2) Explain 'just' and 'equal' temperament.

(3) Describe the formation of the scale of any keyboard instrument (piano, harmonium, etc.). Is the octave of a fundamental 'like' the fundamental? What do you mean by psychological 'likeness'? Can you suggest a diagram that shall represent the character of the tonal scale more accurately than is done by a straight line?

(4) Work out the correlation between clang-tint and partial tones in the principal orchestral instruments.

(5) Differentiate the physical stimuli of simple noise, simple tone and clang.

(6) Give a theory of the auditory qualities.

EXPERIMENT V

§ 13. **The Phenomena of Interference: Beats.**—If two forks of the same pitch are struck simultaneously or in quick succession, we hear a tone which is louder than the tone proceeding from either fork separately. And the more nearly the phases of the air-waves coincide, — the more closely the hills and valleys of the one curve correspond to the hills and valleys of the other, — the louder is this resulting tone. Contrariwise, if the phases are in complete opposition, the hills of the one curve coinciding with the valleys of the other, the resulting tone has the intensity 0, and is consequently not heard at all. Silence is produced as the effect of the *interference* of the sound waves.

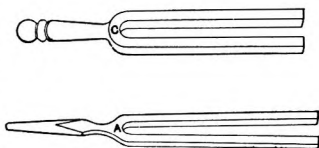

FIG. 7.

Every tuning-fork shows the phenomena of interference, since its prongs vibrate in opposite directions.

MATERIALS.—Tuning-fork. Felt hammer. Resonance-jar. Short tube of wood or rubber, large enough to slip over a prong without touching.

PRELIMINARIES. — *E* tunes the resonance-jar, roughly, to the tone of the fork, by pouring in water until the tone is distinctly strengthened by holding over the mouth of the jar.

EXPERIMENT (1). — *O* sits with his eyes closed, and his better ear turned towards the resonator. *E* takes the fork, and turns it slowly round its longitudinal axis over the mouth of the resonator. In one complete revolution *O* will distinguish four positions in which the sound is strong, and four intermediate positions in which it is inaudible. The first four are the positions in which one of the prongs, or one of the lateral surfaces of the fork, is turned towards the jar; the other four, the positions of silence, lie between these, practically in planes which make an angle of 45° with the surfaces of the prongs, and pass through the axis of the fork.

(2) *E* holds the fork in a position of silence, and suddenly slips the tube over one of the prongs, taking care not to touch the fork. *O* immediately hears the tone: the influence of the covered prong is almost wholly destroyed, and the uncovered prong acts alone and undisturbed. —

Similar fluctuations of intensity occur when two tones of slightly different pitch-number are sounded together. Suppose, *e.g.*, that two tones differ by 1 vibration per sec., and that at the moment of excitation their sound-waves are in the same phase. At every recurring second there is recurrence of this identity of phase; but during each second the one tone makes one whole vibration (hill and valley) less than the other. It follows that at the end of every first half-second a hill of the one curve coincides with a valley of the other, and the intensity of the resulting tone is weakened, — while at the end of every second half-second the reinforcement of the one wave-movement by the other brings about an increase of intensity. The two tones ‘beat’ once in every second. — In the same way, tones whose pitch-numbers differ by two vibrations per second beat twice in the 1 sec., and so on.

The counting of beats is done as follows.

MATERIALS. — Two tuning-forks of the same pitch. Felt hammer. Resonance-jar. Wax. Stop-watch.

PRELIMINARIES. — *E* tunes the resonator, as before. He

flats one fork a trifle, by sticking a fragment of wax to one of the prongs, near its extremity. *O* sits at the table on which the resonance-jar is placed, the stop-watch lying before him.

EXPERIMENT (3). — *E* gives the ready-signal to *O*, and strikes both forks sharply with the hammer, making the two blows so far as possible of equal force. The forks beat loudly as they are held over the resonance-jar. On hearing *E*'s "Now!" *O* makes ready to count. Fixing his eyes on the watch, he waits until the moving hand lies evenly upon a second's mark, and then counts the beats for 10 sec. It is easier to count "one, two, three . . ." than to count "nought, one, two . . ." If he counts in this way, however, *O* must always remember to throw off one beat at the end of the count. If, *e.g.*, he has counted 37 in the 10 sec., the number of beats was 36. This experiment should be performed 5 times over.

To check the result of the count by single beats, *O* should further count the beats in twos and fours. (4) The two-count is best taken in the rhythm one'-ty, two'-ty, three'-ty, etc., up to the two-syllable numerals, thir'-teen, four'-teen, etc. Thus the 37 count would end with the syllable 'nine' of nine'-teen. There are therefore $18\frac{1}{2}$ paired beats, *minus* the $\frac{1}{2}$ paired beat to be subtracted, in the 10 sec., — or 36 beats. This count should also be made 5 times over. (5) The four-count may be taken in the rhythm one'-ty-ah-ty, two'-ty-ah-ty, . . . thir'-teen-ah-ty, etc. The 37 count would end, *e.g.*, with the syllable 'ten' of ten'-ty-ah-ty. There are, therefore, $9\frac{1}{4}$ four-beats, *minus* the $\frac{1}{4}$ four-beat to be subtracted, in the 10 sec., — or 36 single beats. This count should be made 5 times, as before.

For the final result, the average of all three counts (15 series) is taken.

(6) A number of short series of experiments should be made, with different weights of wax, in order to determine the limits within which beats may be easily and accurately counted. —

What, now, is the *pitch* of the beating tone-complex? There are, evidently, several possibilities. We might, *e.g.*, hear both tones at their own pitch, and hear both of them beating; or we might hear the one tone beating and the other sounding continu-

ously ; or we might hear only a single beating tone, whose pitch should lie (perhaps) midway between the pitches of the primary tones. What are the facts ?

EXPERIMENT VI

§ 14. **The Pitch-difference of the Two Ears.** — It rarely (indeed, in all probability it never) happens that the two ears respond to a tonal stimulus by precisely the same tonal sensation. 'The same tone' is 'heard differently,' a little higher in pitch by the one ear than by the other. The object of the present experiment is to ascertain the fact of this pitch-difference, and to determine its amount.

MATERIALS. — Two c^2 -forks. Two a^1 -forks. Wax. Felt hammer.

EXPERIMENT (1). — *O*, seated comfortably in his chair, takes a c -fork in either hand, grasping the stem firmly between thumb and forefinger. He closes his eyes, and holds the two forks out, in front of him, a few inches apart ; the forks are so turned that their prongs will vibrate in the vertical plane. *E* takes the hammer, and strikes sharply down upon the two upper prongs, in quick succession, and as evenly as he can. *O* then raises the forks alternately to the two ears : first the right fork to the right ear, then (as soon as the pitch has been accurately cognised, thoroughly impressed upon the mind) the left to the left ear, and so on, until the tones become too weak for certain identification. A difference in pitch may quite possibly be noticed at the first trial. If this is not the case, the experiment must be repeated, *O* this time raising the left fork first. After a few trials, he will be able to say decidedly that one of the forks is higher in pitch than the other.

(2) This (the higher sounding) fork must now be flatted. *E* takes it, and sticks a fragment of wax to one of its prongs. He then returns it to *O*. The two forks are struck, as before, and the comparison repeated. If the flatted fork still sounds too high, a little more wax is stuck on, and the comparison made again. The procedure is continued till the forks sound exactly alike. — *O* knows, throughout, that the fork is being flatted, but should not be allowed to see the wax attached to the prong.

(3) The two forks, the flatted and the normal, are now allowed to beat, and the beats are counted (see Exp. V.). Let us term the number of beats per second n , and suppose that the pitch of the forks is 528, *i.e.*, that their prongs vibrate back and forth (complete vibration) 528 times in the 1 sec. Then the experiment shows that a tone of 528 heard by the duller ear is identical with a tone of $528 - n$ vibrations heard by the sharper ear. Now the note next below c on the musical scale is b ; and a c^2 of 528 corresponds to a b^1 of 495 vibrations. The 'half tone' $b^1 - c^2$ consequently covers 33 vibrations; and the fraction $n/66$ gives the pitch-difference of the two ears in terms of a musical 'tone.'

(4) The experiment is repeated, in the opposite direction. The fork already flatted is flatted still more, by additional wax. O is informed of this, and told that the tone will grow sharper at each succeeding trial: he does not see the manipulation of the wax. In the first trial, the flatted fork is, of course, distinctly too low in pitch, as compared with the normal fork heard by the duller ear. E therefore pares off a morsel of wax; again, O finds the tone too flat. The paring is continued, little by little, and further comparisons made, until the two forks sound alike.

They are then allowed to beat, and the number of beats per second, n' , is determined. The tone of 528 heard by the duller ear is thus proved equal to a tone of $528 - n'$ heard by the sharper.

For the final result, the two part-determinations, the descending (flattening) and the ascending (sharpening) are averaged. The pitch-difference of O 's two ears, at this point of the tonal scale, is $n + n'/2$ vibrations, or $n + n'/132$ of a musical tone.

(5) Both halves of the foregoing experiment may be repeated with the a -forks. If c^2 is a tone of 528, a^1 is a tone of 440 vibrations in the 1 sec. The 'whole tone' $g^1 - a^1$ covers 44 vibrations. From these data the results are worked out as before.

EXPERIMENT VII

§ 15. **Combination-tones.** — (*A*) When two tones, chosen within the limits of the octave, are sounded together, there arise, in addition to these tones themselves, certain other tones

whose pitch-numbers stand in various simple relations to the pitch-numbers of the generating tones. These extra-tones, 'combination-tones' (also termed 'resultant tones,' 'third tones'), are of three kinds. We have (1) the 'first difference-tone,' whose pitch-number is the difference between the pitch-numbers of the two primary tones. Thus, if the a^1 of 440 in the 1 sec. is sounded together with the c^2 of 528, a tone of $528 - 440$ or 88 vibrations in the 1 sec., the tone F , is also produced. This F is the first difference-tone of a^1 and c^2 . Again, we have (2) the 'second difference-tone.' Let l be the pitch-number of the lower generator, and u that of the upper. The pitch-number of the first difference-tone is $u - l$. The pitch-number of the second difference-tone is $2l - u$. Thus the a^1 and the c^2 give a second difference-tone of $2 \times 440 - 528$, or 352, the tone f^1 . Finally, (3) a tone is set up whose pitch-number is the sum of the pitch-numbers of the primaries. This is the 'summation-tone.' The summation-tone of the a^1 and the c^2 is a tone of 968, a rather flat b^2 .

I. The First Difference-tone

The first difference-tone, $u - l$, is also known as 'Tartini's tone' (so called from its discoverer, the Italian violinist G. Tartini, 1692-1770) and as 'lower beat-tone.' Like the other combination-tones, it is a pure tone, not a clang; and, also like

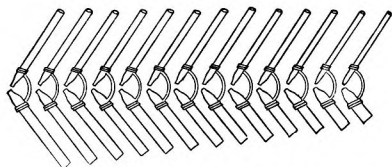

FIG. 8. — Set of Quincke's tubes.

them, it is an ear-tone and not an air-tone,—a tone set up by the function of the ear itself, and not by any objective wave-motion of the air. The present experiment shows us how to distinguish it, and to trace its relation to the generators.

MATERIALS. — Set of Quincke's tubes, g^3 to g^4 , numbered 1-13. Wax. Corks to fit the tubes.

PRELIMINARIES. — E must see that the wires of the tubes are secure, and that the mouth-pieces are properly adjusted to the resonators. A lump of wax should be used, to hold the tubes together in the right position: otherwise there will be slipping

of the wires, and general disturbance of adjustment, as the pairs are lifted from the table and laid down again. When all the tubes have been set to give a loud, clear, full, sustained note, the experiment can begin.

O sits, with closed eyes, sidewise to the table on which *E* has arranged the tubes, his better ear turned towards the source of sound. Attention should be concentrated upon the perception of this one ear, and not distributed to the two ears.

EXPERIMENT (1). — *E* takes the tubes marked 1 and 5 (major third), and sounds each two or three times over, in order to accustom *O*'s ear to the pitch of the generating tones. Then, after a preparatory signal, he sounds (*a*) the lower tone by itself, for a couple of seconds, and (*b*), with as little interruption of continuity as possible, the two tones together. At the moment when the higher tone is added, a difference-tone is produced which lies two octaves below the lower of the primary tones (vibration-ratio of major third is 4 : 5; $u - l$ is 1; the ratio 1 : 4 is the ratio of the double octave). The tone is of moderate loudness, and is so much lower in pitch than the *l* of the tubes that *O* should find it easily recognisable. The experiment must, however, be repeated, until *O* is entirely satisfied with his introspections.

(2) *E* takes the tubes marked 1 and 8 (fifth), and proceeds as before. The difference-tone, which lies one octave below the lower generating tone (vibration-ratio of fifth is 2 : 3; $u - l$ is 1; the ratio of 1 : 2 is that of the octave), is very loud. Again, *O* ought to have no difficulty in distinguishing it from the lower generator.

(3) However, the tones of the octave (1 : 2) are easily confused. Hence it will be well to verify the result of introspection in this case. The difference-tone of tubes 1 and 8, open, is plainly the proper tone of tube 1, stopped. *E* accordingly repeats the experiment with the fifth; and, when *O* has the difference-tone clearly in mind, quickly corks tube 1, and sounds it alone. *O* should be certain of the identity of this new tone and the remembered difference-tone.

(4) *E* now gives the intervals from the fifth to the octave, in regular order: minor sixth, major sixth, minor seventh, major

seventh, octave. The difference-tones advance nearer and nearer to the tone of the lower generator, ascending by greater intervals than the minor second of the generators. Are they audible?

O's introspection can be verified in every case. Thus:

Difference-tone of tubes	1,	9	open	is	tone	of	tube	4	stopped
"	"	"	1, 10	"	"	"	6	"	"
"	"	"	1, 11	"	"	"	9	"	(nearly)
"	"	"	1, 12	"	"	"	11	"	"
"	"	"	1, 13	"	"	"	1	open	"

The tones of stopped tubes 9 and 11 are a trifle too sharp to accord with the difference-tone. The difference-tone of open tubes 1 and 13 is, of course, not heard separately at all, being identical with the tone of the lower generator.

(5) Five intervals remain to be investigated: the tri-tone, fourth, [major third,] minor third, major second, minor second. If the pairs of tubes are sounded in this order, *O* will readily follow the series of difference-tones. Note that they are of great depth, descending by much wider intervals than the minor second of the generators.

(6) At this stage of practice, *O* should be able to hear the first difference-tone, (*a*) when the intensity of the generators is but slight, (*b*) when the two intensities are markedly unequal, and (*c*) when the duration of the primary tones is short. The first and third of these tests can be made by *E*; the second must be made by *O* and *E* together, *E* sounding the loud and *O* the soft tone. Intervals should be chosen which have given good difference-tones in the foregoing experiments.

II. The Second Difference-tone

The second difference-tone, $2l-u$, is also known as the 'upper beat-tone.' Its pitch is sometimes higher, and sometimes lower, than that of the first difference-tone.

Materials and *Preliminaries* as before.

EXPERIMENT (7).—*E* takes the open tubes 1 and 12 (major seventh), and proceeds as in (1). A second difference-tone is produced which lies three octaves below the lower of the generating tones (vibration ratio of major seventh is 8:15; $2l-u$ is

16-15, or 1; the ratio 1:8 is that of the triple octave). The experiment is repeated until *O* is satisfied with his introspections.

(8) *E* takes tubes 1, 6, 8, 10. The first difference-tone of 1 and 8 (fifth), as we saw, lies an octave below tube 1. The second difference-tone has here the same pitch as the first. (The ratio of the fifth is 2:3; and $3-2 = 2 \times 2-3 = 1$; the ratio 1:2 is that of the octave.) Hence the resultant difference-tone of this interval is much louder than either difference-tone of any other interval. *O*'s attention was called to the intensity of the 'first difference-tone' of the fifth in (2) above. He should now compare the difference-tones of fourth (first d.-t.), fifth (combined d.-t.), and major sixth (second d.-t.), as follows:

Tubes.	Tones.	Vib.-ratio.	First d.-t.	Second d.-t.
1, 6	g^3, c^4	3:4	c^2	—
1, 8	g^3, d^4	2:3	g^2	g^2
1, 10	g^3, e^4	3:5	—	c^2

The g^2 is much louder than either of the c^2 's.

(9) The intervals from fifth to octave are given, in regular order. What second difference-tones may be expected? Are they audible?

(10) The intervals from fifth to unison are given in regular order. Are the second difference-tones audible? *O* must verify introspection by help of the stopped tubes.

(11) Experiment (6) may be repeated, with intervals lying between fifth and octave.

III. *The Summation-tone*

The summation-tone is always very weak, and therefore difficult to hear.

MATERIALS. — Harmonium or Ellis Harmonical.

EXPERIMENT (12). — Experiments may be made upon intervals taken at random within the limits c^1-c^2 . Thus the major third

c^1-e^1 gives d^2 as summation-tone; the fifth c^1-g^1 gives e^2 ; the octave c^1-c^2 gives g^2 , etc., etc. Some of these summation-tones should be heard by O . Introspections must be verified upon the instrument.

(*B*) When the two generating tones form an interval wider than the octave, we have the following extra-tones. (1) The first difference-tone either disappears entirely, or at least becomes extremely weak. (2) The second difference-tone persists, as before. (3) A third difference-tone is generated, whose pitch-number is $3l-u$. Thus, if the a^1 of 440 and the c^3 of 1056 be sounded together, the first difference-tone (616, a sharp d^2) is not heard; the second difference-tone (176, f) remains; and a third difference-tone (264, c^1) is added. Lastly, (4) the summation-tone may be heard under favourable conditions.

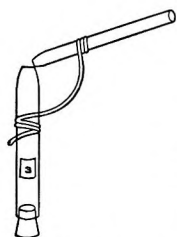

FIG. 9.—Quincke's tube, corked and labelled.

I. The First Difference-tone

Materials and Preliminaries as for I. and II. above. Since the 13 tubes, open and stopped, furnish two complete chromatic scales, experiments can be made, and the results of introspection verified, without additional apparatus.

EXPERIMENT (13). — Five trials may be made, as follows :

Difference-tone of tubes	1 st.	and 13 o.	is proper tone of tube	8 o.
"	"	" 1 st.	" 8 o.	" " " 1 o.
"	"	" 1 st.	" 6 o.	" " " 10 st.
"	"	" 1 st.	" 5 o.	" " " 8 st.
"	"	" 1 st.	" 3 o.	" " " 5 st.

The tube whose proper pitch is that of the expected difference-tone should be sounded first, and carefully memorised by O . Then the two generators should be sounded together, loudly, and quite close to O 's ear: the distance should in no case exceed 25 cm.

II. The Second Difference-tone

Materials as before.

EXPERIMENT (14). — Experiments may be performed as follows :

Tubes.	Tones.	Vib.-ratio.	Second d.-t.
I st., 2 o.	$g^2, a^3 \flat$	15 : 32	$A \flat$
I st., 3 o.	g^2, a^3	4 : 9	g
I st., 4 o.	$g^2, b^3 \flat$	5 : 12	$e^1 \flat$
I st., 5 o.	g^2, b^3	2 : 5	g^1
I st., 6 o.	g^2, c^4	3 : 8	c^2
I st., 7 o.	$g^2, c^4 \sharp$	16 : 45	$e^2 \flat +$
I st., 8 o.	g^2, d^4	1 : 3	g^2

Is the second difference-tone audible throughout? What may be expected to happen if the series is continued?

III. The Third Difference-tone

Materials as before.

EXPERIMENT (15). — The third difference-tones for the intervals employed in (14) above would be :

Tones.	Third d.-t.	Tones.	Third d.-t.
g^2, g^3	g^2	g^2, b^3	g^1
$g^2, a^3 \flat$	f^2 , nearly	g^2, c^4	c^1
g^2, a^3	$e^2 \flat$, nearly	$g^2, c^4 \sharp$	d
$g^2, b^3 \flat$	$b^1 \flat$	g^2, d^4	—

Are these tones audible? What may be expected to happen if the series is continued?

IV. The Summation-tone

MATERIALS. — Harmonium or Ellis Harmonical.

EXPERIMENT (16). — Intervals may be taken at random within the limits c^1 – c^3 . Thus the major tenth, c^1 – e^2 , gives a summation-

tone of b^2 (nearly); the twelfth, c^1-g^2 , gives c^3 ; the double octave c^1-c^3 , gives e^3 , etc., etc. O 's introspections must be verified on the instrument.

(C) Finally, recourse may be had to all the various sources of musical sound that the laboratory possesses, in order to determine the effect of (1) pitch-region, (2) clang-tint, (3) purity of intervals formed by the generators, etc., etc., upon the hearing of the combination-tones.

EXPERIMENT VIII

§ 16. **Pitch and Clang-tint.**—Suppose that the note a^1 is sounded on piano, harmonium and violin. We know that 'the same a ' is given in each case; but we have no difficulty whatever in distinguishing the three 'same a 's,' and in referring each of them to its own musical instrument. The fundamental tone is identical throughout, but the total impression of the clang varies. Such differences are termed differences of *clang-tint*. The violin clang is differently tinted, has a different coloration, so to speak, from that of the piano. Or, to employ another metaphor, each instrument sets its own hall-mark upon its tones, and they reach our ears with this *timbre* upon them.

The character of timbre or clang-tint depends primarily upon the number and relative intensity of the upper partial tones or *overtones* contained, in addition to the fundamental, in the musical note (Helmholtz). (1) If the clang approximates to the simple tone, *i.e.*, has few and weak partials, it is soft and pleasant, but of little strength, and dull or flat in low pitches (*cf.* flute, or organ flute-pipes sounding under low wind-pressure). (2) If the lower partials, up to about the sixth, are present and moderately loud, the clang is rich, musical, harmonious, while still sweet and soft (*cf.* piano, human voice *piano*, open organ pipes, French horn). (3) If only the odd-numbered partials are present, the clang sounds hollow or (if the partials are numerous) nasal (*cf.* clarinet, narrow stopped organ pipes). (4) If the fundamental is not strong enough to dominate the tone-complex, the clang is thin and poor. Piano strings struck by their hammers yield a rich, plucked by the finger a poor sound; reed-pipes with resonators are full and rich in tone, without, thin and bodiless.

(5) When the partials above the sixth are very distinct, the clang is cutting, piercing, rough, harsh (*cf.* bowed instruments, brass instruments, human voice *forte*, oboe, bassoon, harmonium). And it is clear that each of these five rubrics allows of numerous subdivisions. The last, *e.g.*, brackets together harmonium, violin and cornet,—instruments whose tones it would be very difficult to confuse.

It is, then, first of all, the presence of overtones that differentiates piano, harmonium and violin, and enables us to say from which of the three instruments the *a* proceeds.

PRELIMINARY EXERCISE.—If, now, the notes of the various musical instruments differed in no other respect than this of the number and intensity of overtones, they would still be easily distinguishable. In actual fact, however, there are a number of other, more extrinsic differences, which help us very materially in referring a given clang to the instrument which generates it. *O* and *E* may work together (*cf.* p. 5) to discover these differences: four, at least, should reveal themselves to introspection. The determinations may be made from memory, though it's better to make a series of trials upon typical instruments (reed, string, wood-wind, brass-wind, etc.) or to take notes while listening to orchestral music.

Where marked differences of clang-tint obtain, it is not easy, even for musically trained people, to judge of unison by the unaided ear. The piano and the violin 'go together' well. Yet practised violinists know that the pitch of their instrument is likely to be a little too flat, if they tune to apparent unison; experience teaches them that they must make it a trifle sharp, for the ear, if it is to be brought into objective agreement with the piano (Stumpf). Judgment of unison is, however, more especially difficult if the clang-tint of either of the compared notes is relatively unfamiliar. Thus soft and dull tones (flute, blown bottle, wide stopped pipe, tuning-fork on its resonance-box, etc.), which are heard comparatively rarely by themselves, are almost invariably estimated as lower than their true pitch. The statement may be tested, experimentally, as follows.

MATERIALS.—Quincke's tubes. Piano. Piston-whistle, graduated in semitones from c^3 to c^5 .

EXPERIMENT (1).—*E* sounds the note of one of the tubes, which he has selected at random and unobserved by *O*, as steadily as possible, two or three times over. *O*, with the note impressed on his mind by attentive listening, then seeks to 'match' it on the piano keyboard. The test may be repeated, until he is fairly satisfied. Record is kept of the separate trials, of the final match, and of *O*'s introspections during the test (uncertainty, limits of fluctuation, reasons for ultimate choice, etc.).

(2) *O* takes the tube, and *E* the piston-whistle. These two are now to be compared. *E* goes up the scale, semitone by semitone, and *O* sounds the tube immediately after each of *E*'s whistle clangs. At a certain point within the octave limit, the whistle and tube will 'match' in *O*'s introspection; the two clangs resemble each other more closely than did tube and piano in (1). The point of coincidence is recorded.—*E* now runs down the scale, *O* following step for step as before. Again a point is reached (and recorded) at which the clangs match.

The two points of subjective equality may or may not coincide. If they do not, the tone lying midway between them should be selected for the next stage of the experiment.

(3) *E* sets the piston-whistle for the selected tone, and sounds it and the tube together. The two may be in unison. If they are not, but the tones lie fairly near together, a deep (first) difference-tone will be heard. *E* then moves the piston slowly in the direction in which the difference-tone deepens, *i.e.*, in the direction of unison, until the difference-tone vanishes and perfect unison is attained. The pitch-number of the tone can be read from the nearest mark upon the whistle-scale, and the corresponding tone found upon the piano keyboard.

(4) Objective coincidence of whistle clang, tube clang, and piano clang, has now been reached. How near does the correct piano note lie to the note chosen by *O* in (1)?

Tube (or whistle) and its piano-match should be given by *E*, in immediate succession, several times over, in order that *O*'s ear may become accustomed to the recognition of unison beneath the disguise of varying clang-tint.

(5) Other comparisons may be instituted, according to the

resources of the laboratory. Thus, the clangs from tube, whistle and piano may be compared with a tuning-fork tone of the same pitch, with the notes of violin, zither, harmonium, flute, etc.

EXPERIMENT IX

§ 17. **Analysis of a Simple Clang: Overtones.**— We said above, p. 33, that the ‘tones’ of musical instruments are compound tones or clangs; *i.e.*, that their physical basis is not a simple pendular vibration of the air particles, but a vibration of complex form. And we saw in the last experiment that the clang-tint of a given instrument affects the apparent pitch of its notes. We have now to isolate the upper partials that are contained in a simple clang, and so to analyse the clang into its simple sense-elements.

The rule by which the ear proceeds in its analysis was first laid down as generally true by the German physicist G. S. Ohm (1787–1854). “Every motion of the air, which corresponds to a composite mass of musical tones, is, according to Ohm’s law, capable of being analysed into a sum of simple pendular vibrations, and to each single simple vibration corresponds a simple tone, sensible to the ear, and having a pitch determined by the periodic time of the corresponding motion of the air” (Helmholtz). The French mathematician J. B. J. Fourier (1768–1830) showed, further, that “any given regular periodic form of vibration can always be produced by the addition of simple vibrations, having pitch-numbers which are once, twice, thrice, four times, etc., as great as the pitch-numbers of the given motion” (Helmholtz). Since this mathematical analysis is objectively valid, — since, *i.e.*, “every individual system of waves formed by pendular vibrations exists as an independent mechanical [not merely mathematical] unit,” and “each single tone can be separated from the composite mass of tones, by mechanical means,” — we may represent the composition of a perfect clang as follows :

$$1 : 2 \quad 3 \quad 4 \quad 5 \quad 6 \quad 7 \quad 8 \quad . . .$$

where 1 is the pitch-number of the fundamental, and 2, 3, etc., are the pitch-numbers of the upper partial tones or overtones.

For instance, the first ten partials of the note *C* of the great octave (66 vs.) are represented thus, in musical notation :



The upper partials grow fainter and fainter, in proportion to their distance from the first partial or fundamental. Nevertheless, with practice and careful direction of the attention, we are able to hear a good number of them. The best instruments for experiment are strings, the harmonium or harmonical, and the more penetrating organ stops.

MATERIALS. — Monochord or sonometer. [This consists of a sounding board and box, of wood, over which a single string (wire) is stretched. The tension of the string can be increased

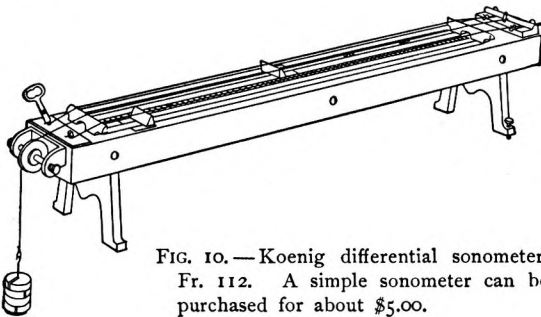

FIG. 10. — Koenig differential sonometer, Fr. 112. A simple sonometer can be purchased for about \$5.00.

or diminished at will. In some instruments, the one end of the string is attached to a screw, which can be tightened or loosened by means of a piano-key; in others, the free end of the string passes over a pulley-wheel, and carries a scale-pan in which weights may be placed. The former arrangement is the more satisfactory for tuning. Below the string lies a divided scale (usually 1 m. in length), to facilitate the discovery of the nodes.] Stiff camel's-hair pencil, pointed at the tip.

EXPERIMENT. — *O* sits near the instrument; his eyes are closed, and his better ear is turned towards the source of sound. *E* presses the camel's-hair brush firmly down upon the string at a point one-third of its length from the end, and plucks the string at about one-seventh of its length from the other end. The note given (consisting of the third, sixth, ninth, . . . par-

tials, in order of decreasing intensity) has the pitch of the third partial of the full string. When *O* has this tone well in mind, *E* sounds the note of the whole string, by plucking as before, and, while the note is still ringing, touches the string lightly with the pencil at the point touched in the previous experiment. The third partial sounds out clearly and loudly, with the fundamental of the string gently accompanying it. The experiment is repeated, the pencil brushing the string more and more lightly each time; so that *O* passes by very gradual stages from the isolated partial to the clang of the full string. At last he will be able, without assistance, to hear the partial sounding in the natural musical tone of the string.

Repeat the experiment for the fifth partial. When this has been heard, proceed to the fourth, sixth and second partials, in that order. Then, plucking the string nearer the end than one-seventh, experiment for the seventh, etc., partials, up to and including the tenth.

CHAPTER III

CUTANEOUS SENSATION

§ 18. **Cutaneous Sensation.** — The skin has many functions to perform in the economy of the organism. It protects the underlying soft tissues from injury; it carries the hair and nails; it contains sweat-glands and oil-glands. It is, further, the oldest of the organs of special sense. We do not obtain from it a series of graded sense qualities, as we do from the ear, or in still greater variety from the eye; it yields us four detached sensations, of unchanging quality. Three of these, the sensations of pressure, warmth and cold, come from the cutis proper; one, the sensation of pain, comes from organs in the epidermis.

It is tempting to regard the four skin qualities as types of primitive sensation, to look upon them as representing each the potentiality of a series. We might then parallel, *e.g.*, warmth and cold with the dark and light of the primitive eye: the dark and light which were merely dark and light, incapable of gradation, not terms in a series of brightnesses such as we ourselves possess. Or we might parallel pressure with the noise sensation of the primitive ear: the noise which was the sole auditory quality, just differentiated from the bodily tremor or vibration out of which hearing would seem to have developed, not a definite term in such a series of noise qualities as our own ears furnish. But we must remember that the skin has been shaped by natural selection for its offices as surely as have the eye and the ear for theirs. While it is true that the skin qualities have resisted differentiation, it cannot be true that they have persisted altogether without modification through the animal series. They are undoubtedly clearer-cut, less cloudy, more definite and more easily discriminable, than the corresponding sensations in lower organisms. They take us far back in the scale of minds,

but not so far as do, *e.g.*, the organic sensations of hunger and thirst.

We are accustomed to pair the sensations of warmth and cold, functionally, as belonging to a single sense of temperature. Nevertheless, their organs are quite distinct: differently localised, and different in structure. The only psychological reason for putting them together is that they coöperate, under certain conditions of stimulation, to furnish a new perception quality, that of heat.

We are accustomed also to think of the sense of pressure as subdivided into a number of distinct qualities: contact, impact, pressure, touch, resistance; hardness and softness, roughness and smoothness, sharpness and bluntness, wetness and dryness. These terms are, in reality, one and all names of perceptions, not of sense qualities. In sensation, *e.g.*, contact and pressure are indistinguishable, save in degree of intensity; a contact is a very light pressure. When the two are distinguished, in popular psychology, the distinction is one of perception: a contact is a pressure which, by its lightness, does not suggest any determinate pressing object; a pressure is a pressure of something, of a definite physical body. The stimulus is then generally imaged in visual terms.

Pain is mediated by the deeper-lying tissues, as well as by the skin. We have no accurate knowledge of the pain-organs in muscle, etc. Nor can we say at present whether the various kinds of pain—dull, sharp, gnawing, piercing, stabbing, pricking, shooting, aching, sore—represent different pain qualities, or owe their characteristic colouring to intensive (dull, sharp), temporal (throbbing, beating), and extensive (thrilling, pricking) differences, and to intermixture with pressures. Cutaneous pain is of one quality throughout.

PRELIMINARY EXERCISES.—The law of adaptation obtains for pressure, warmth and cold, as it does for vision.

Prepare three bowls of water. The two hands are placed in the two outer bowls. The water in the one of these is gradually cooled, and that in the other gradually heated. The middle bowl contains lukewarm water. Presently the two hands are plunged together into the water of the middle bowl. It will

feel distinctly warm to the one, and as distinctly cold to the other.

Weight a large cork with sheet lead. Stand the cork upon the broad part of the fore-arm, and let *O* close his eyes. After a little time (varying with the weight of the cork) the pressure sensation will have entirely disappeared. *Cf.* our indifference to the weight of our ordinary clothing.

QUESTIONS. — (1) Give Hering's theory of the temperature sense. Criticise it.

(2) What do we know of the organs from which the four cutaneous qualities are derived?

EXPERIMENT X

§ 19. **Temperature Spots.** — This experiment enables us (1) to discover, and accurately to record, the sense-organs of temperature, which lie scattered about the surface of the skin; and (2) to become introspectively familiar with temperature sensations in their purest form.

MATERIALS. — Two metal cylinders, about 1 cm. in diameter, ending below in a smooth point and above in a disc of about

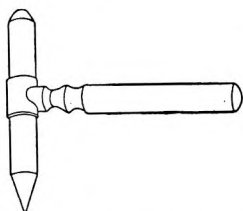

FIG. 11. — Temperature cylinder. Chicago Lab. Supply Co., \$1.00.

.5 cm. diameter, and carried in an adjustable clip, to which a transverse wooden handle is attached. Architects' paper. Aniline dyes, red and green, in weak solution; indelible ink; fine camel's-hair brushes. Millimetre scale. Two shallow earthenware pans, a larger and a smaller, to take a freezing mixture of salt and ice, and cold water, respectively. A Bunsen burner, with rubber tubing to attach it to the gas fixture.

PRELIMINARIES. — *O* lays out his left hand, lightly clenched, on the table, dorsal side upwards. The skin in the region of the second and third metacarpals thus presents a smooth, slightly strained surface. In this region, beginning from points situated to right and left of the interosseous space and lying about 1 cm. from the distal ends of the metacarpal bones, *E* marks out a parallelogram in indelible ink: the width (right-left direction)

may be 1.5 cm., the length (peripheral-central direction), 2 or 2.5 cm. This is the area to be explored. Six corresponding parallelograms are drawn upon the architects' paper.

EXPERIMENT (1). *Cold Spots*. — The smaller pan having been set in the larger, the points of the two cylinders are laid in the cold water, the cylinders resting by their projecting handles on the edge of the vessel. A cooled cylinder is taken by *E*, wiped dry, and (after the signal for attention) passed along one of the sides of the parallelogram. It must be moved slowly and steadily, with a firm but not intensive pressure, and must always be held vertical to the skin surface. When a cold spot is found, *O* says 'Cold!' or 'There!' *E*, however, does not immediately arrest the cylinder; he continues the movement for about 1 mm., in order that the spot may be exactly localised at the point of clearest sensation. The spot is then marked on the skin with a dot of green dye. If the sensation obtained from it be very intensive, one of the outline maps is laid over the skin, and a tiny ink cross made on the paper at the point where the dye shows through. After a signal, the movement of the cylinder is continued. If the instrument has lost appreciably in coolness, it is laid in the cold water, and the other cylinder substituted for it.

When this line has been worked over, and its cold spots noted, another line is begun, which runs parallel to it at a distance of 1 mm. When this has been investigated, a third is begun; and so on, until the whole area has been traversed at millimetre intervals either in the *PC* or in the *RL* direction.

The first series of experiments is now concluded. *E* lays one of the outline maps of the surface over the surface itself, and makes ink-dots at the points (not already marked with crosses) where the green dots show through the paper. He thus obtains a permanent record of the sense-organs of cold situated within this particular skin area; and the record distinguishes the points of very intensive from those of only moderately strong cold sensation. *O*'s hand may now be washed, only the indelible ink marks remaining.

The temperature spots are easily fatigued, and it is therefore unwise to attempt at once to verify the results of these first

experiments. At a later sitting, however, the same area must be worked over a second time, in the opposite direction (*RL*, if the first lines were *PC*, *PC* if they were *RL*). A second map is thus obtained. The two maps are then laid together, and a third map constructed from them. In this, the spots which were found in both experimental series are marked in green; those which were found in one series only, in ordinary black ink. The ink crosses are marked in, over the colour, when this is dry. All maps made are to be inserted in the note-book; not pasted in, but framed in four diagonal slits which receive their corners.

(2) *Warm Spots*.—That portion of a cylinder which lies between the lower edge of the clip and the beginning of the point is turned slowly in the flame of the Bunsen burner, until the metal has become perceptibly but not unpleasantly warm. The experiment is performed precisely as it was in the case of the cold spots, except that the warmed cylinder must travel over the skin somewhat more quickly than the cooled cylinder. Two preliminary maps (of red dots and ink crosses) are made. The warm spots which are found in both experimental series should be marked on the third, final map, in red; the others in ordinary black ink.

RESULTS.—*E* has his six maps, and the record of the introspections volunteered by *O* in the course of the experiments.

The following Questions arise.

E (1) Are the cold spots or the warm spots the more numerous? What types of distribution do they show? Are these types the same for both kinds of spots? Is it right to mark the two kinds by dots of the same size?

E (2) Which set of spots proved to be the more easily verifiable: the intensive set, marked by crosses, or the moderate set, marked by dots, in the preliminary maps?

O (3) The sensations of warmth and cold differ in quality. What other differences between them does introspection reveal?

O (4) Did you experience nothing but cold at the cold spots, and nothing but warmth at the warm spots?

E and *O* (5) What other experiments can you suggest, as likely to throw light upon the problems of the temperature sense?

EXPERIMENT XI

§ 20. **Temperature Sensitivity: Areal Stimulation.**—In Exp. X. we discovered and mapped a number of punctiform sense-organs, which we found to furnish us with sensations of varying intensity. The object of the present experiment is to ascertain how these organs (warm spots or cold spots) respond to a stimulation which is continuous over an area of some little size. We spread a stimulus, hot or cold, over a mosaic of temperature spots: what is the mental process set up?

MATERIALS.—As in Exp. X. Further: a thermometer (C.), a tripod with wire gauze to place over the Bunsen burner, vessels for heating and mixing water.

PRELIMINARIES.—On a convenient area of the skin,—say, the radial-dorsal surface of the fore-arm, just below the elbow-joint,—mark out a parallelogram 5 cm. long and 3 cm. wide. This is the area to be explored. Corresponding parallelograms are drawn upon the architects' paper.

Keep water heated over the Bunsen burner. The experiment requires a constant temperature of stimulus: use, for cold stimulation, 12° – 15° C., and for warm, 37° – 40° C.

EXPERIMENT (I). *Cold.*—The flat ends of the two cylinders are laid in the cold water. A cooled cylinder is taken by *E*, wiped, and (after the signal) pressed down for 1 sec. at a corner of the parallelogram. On its removal, *O* says 'intensely cold,' 'cold,' 'just (barely) cold,' or 'nothing.' The skin is marked in accordance with these results: for 'intensely cold,' the little circle is painted all over with the green dye; for 'cold,' it is heavily blotched; for 'barely cold,' dotted; and for 'nothing,' left unmarked. After the marking is finished, *E* gives the signal again, and sets the cylinder down upon the surface adjoining the circular area just stimulated. Record is taken, as before. This procedure is continued until the whole parallelogram has been stamped over, with the exception of the small tetract surfaces left between the circles.

The skin-map is now transferred to architects' paper, which is marked in the same way as the skin. After this has been done, the experiment is resumed, the cylinder being laid over the tet-

ract surfaces, in order. At the end of the series, the interstitial spaces on the paper map are filled up.

This whole experiment must be repeated, for purposes of verification, at a later sitting.

(2) *Warmth*.—A similar experiment is performed, upon the same area, with the warmed cylinders. The different degrees of warmth are more difficult of discrimination than those of cold; so that the two maps made at these two sittings may not agree quite so well with each other as the two maps previously made. Nevertheless, the three degrees of warmth can be distinguished by careful introspection.

RESULTS.—The maps are to be treated as in the previous experiment. Doubtful places in the final cold map (green) and the final warmth map (red) are to be outlined in ordinary black ink. Within the spaces thus left, *E* writes “3 or 2” (if *O* has said ‘intensely cold’ and ‘cold,’ in the two trials); “3 or 1” (if *O* said ‘intensely cold’ and ‘just cold’); etc.

The following Questions arise.

O (1) Which is the easier experiment, from the point of view of introspection: this or the preceding? Give reasons for your answer.

E (2) Do the results of this experiment in any way confirm those of the preceding? Give instances.

O (3) Does the areal stimulus call up in every case an uniform intensity of temperature sensation, or are there ever differences of intensity within the .5 cm. circle?

O and *E* (4) How is it possible that the stimulation of discrete organs, of a mosaic of temperature spots, should give rise to a continuously extended and unbroken sensation? Can you think of analogies from any other sense departments?

EXPERIMENT XII

§ 21. **Pressure Spots**.—This experiment answers the same questions in regard to the sense of pressure that Exp. X. answers in regard to that of temperature. We have to map out the sense-organs of pressure, and to familiarise ourselves with the pressure quality.

MATERIALS.—Rounded point of hard wood, not exceeding 1 mm. in diameter, adjustable in a clip to which a transverse wooden handle is attached. Architects' paper. Blue and violet dyes, in weak solution; indelible ink; fine camel's-hair brushes. Millimetre scale. Scissors. Reading glass (biconvex lens of short focus).

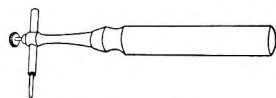

FIG. 12. — Pressure point. Chicago Lab. Supply Co., \$1.00.

PRELIMINARIES. — *O* lays out his hand, lightly clenched, on the table, dorsal side upwards. Over the interosseous space between the fourth and fifth metacarpals *E* marks out a square, of 1 cm. side, in indelible ink. Four similar squares are drawn on the architects' paper.

E now proceeds to make a map of the hairs lying within the marked space upon *O*'s hand. The hairs are cut off short with the scissors, a few at a time, and a tiny dot of blue is made upon the skin at the point where each shaft emerges. Part of the square may seem to be hairless; in that case, it must be worked over with the magnifying glass, in order that no fine hairs may escape notice. The blue-dotted map is then transferred to architects' paper, and the skin washed.

EXPERIMENT. — *E* takes the instrument, and (after the signal for attention) passes along one of the sides of the square, not continuously, as for temperature, but with separate pressures, set as near together as possible. The point of the instrument must make a noticeable depression in the skin at each application. The point should be moved steadily; not dabbed down and jerked away. It must always be held vertical to the skin surface. When a pressure spot is found, *O* calls out 'There!' *E* continues the movement of the point for another step or two, in order to localise the spot at the place of clearest sensation. The spot is then marked on the skin with a dot of violet dye. If it is very intensive, a cross may be made, in ink, on the architects' paper, as in the case of temperature.—After a signal, the movement of the point is continued.

When this line has been worked over, and its pressure spots noted, another line is begun, which runs parallel to it at a

distance of 1 mm. When this has been investigated, a third is begun; and so on.

A first map of pressure spots is now made, upon the architects' paper, and *O*'s hand washed.

The pressure spots are easily fatigued; the results of the first series of experiments cannot, therefore, be immediately verified. At a later sitting, the square must be worked over in the opposite direction. A second map is thus obtained. The two maps are then laid together, and a third constructed from them. In this, the spots which were found in both experimental series are marked in violet; those found in one series only, in ordinary black ink: the ink crosses are marked in, over the colour, when this is dry. All three maps are inserted in the note-book.

RESULTS. — *E* has his final pressure-spot map, to compare with the map of hairs; and the record of *O*'s introspections.

The following Questions arise.

E (1) What is the relation of the pressure spots to the hairs? Can you get by stimulation of the hair itself a pressure that is identical, for *O*'s introspection, with those obtained from the pressure spots? Do pressure spots occur in hairless regions? Do they give the same sensation as is given by the hair-spots?

E (2) Which set of spots is the more easily verifiable: the intensive (marked with crosses) or the moderate (marked with violet dots)?

O (3) What introspective differences are there between the sensation evoked by strong and that evoked by weak stimulation of a pressure spot?

O (4) Quality apart, which of the temperature sensations does that of pressure more nearly resemble?

O (5) Did the stimulus call out any other sensation than that of pressure?

E and *O* (6) Can you suggest further experiments?

EXPERIMENT XIII

§ 22. **Pain Spots.**—This experiment resembles Exps. X. and XII. We have to map out the organs of cutaneous pain, and to learn to distinguish the pain from the pressure quality.

MATERIALS. — A number of stout horse-hairs, sharply pointed by a razor or scalpel, to be attached by wax to a light wooden rod inserted (in place of the pressure point) in the pressure-spot apparatus. Millimetre paper; brown dye; indelible ink. Razor. Fine sponge, mounted on wooden handle; soap and water; fine cloth. Magnifying glass.

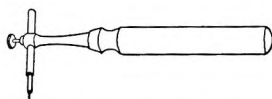

FIG. 13. — Pain point.

PRELIMINARIES. — *E* marks out, in indelible ink, two parallelograms of 2 mm. width within the *P* and *C* sides of the square worked over in Exp. XII. He thus has two areas, each of 20 sq. mm., in place of the single 100 sq. mm. area of the previous Exp. These 40 sq. mm. are to be tested for pain spots.

The two parallelograms are reproduced, upon an enlarged scale, on the millimetre paper. The fine furrows that cross and recross the skin within each area are carefully mapped upon the paper.

The skin is thoroughly softened with soap and water, and then shaved. The areas must be gone over with the magnifying glass, in order that no fine hairs escape notice. It is essential that the skin remain moist and 'flabby' throughout the experiment. To secure this condition, work should be begun upon one of the areas, while the other is kept moist by repeated applications of the wet sponge. As soon as the first area shows any sign of drying, *E* passes to the second, and begins work upon that, keeping the original area moist by sponge applications; and so on, shifting from area to area alternately. Drops of water are removed by the cloth.

EXPERIMENT. — *E* takes the instrument and (after the signal for attention) passes along one of the sides of the chosen parallelogram, dot by dot, as in the pressure experiment. The horse-hair point must be set down firmly, so as to produce a distinct depression of the skin, but care should be taken that it does not pierce the epidermis. As a general rule, it must be held down a little longer than is necessary for the arousal of pressure sensations.

When a pain spot is found, *O* calls out 'There!' *E* immediately transfers the spot to the enlarged map, localising it by the skin furrows: the magnifying glass will probably be of assist-

ance. If the sensation is very intensive, the cross may replace the dot on the map. After a signal, the movement of the point is continued.

Both areas are thus traversed, line by line, until the two maps are complete. At a later sitting, when the skin has fully recovered from its fatigue and possible soreness, the parallelograms are worked over, in the opposite directions, and two new maps thus obtained. A third map is constructed from each pair, in which the spots found in both experimental series are marked in brown; those found in one series only, in ordinary black ink: the ink crosses are marked in, over the colour, when this is dry. All six maps are inserted in the note-book.

RESULTS. — *E* has his final pain-spot maps, and the record of *O*'s introspections. The portions of the pressure-spot map that correspond to the two pain-spot maps should be enlarged, upon the same scale, and the distribution of the spots compared.

The following Questions arise.

O (1) Quality apart, which of the other three cutaneous sensations does that of pain most nearly resemble?

O (2) Give a full introspective characterisation of the pain quality.

E and *O* (3) What is the number of the pain spots, as compared with that of the pressure and temperature spots? Are they related to any peripheral structures, as the pressure spots are related to the hairs?

E and *O* (4) Why do we moisten the skin in this experiment?

E and *O* (5) Can you suggest further experiments?

CHAPTER IV

GUSTATORY SENSATION

§ 23. **Gustatory Sensation.** — There is a fairly close analogy between the skin and the tongue. Both organs have to be explored, point by point, for the determination of their sense qualities; both yield up four of these qualities, — the only true tastes being sweet, sour, bitter and salt; and the qualities are, in both cases, detached and separate, not arranged in a series.

Nevertheless, taste is 'a sense,' while cutaneous sensations belong to four, or at least to three, 'senses.' The four tastes are, for introspection, just as much alike, just as clearly members of a single group, as are the six visual ultimates, — black, white, red, green, blue, yellow. It is true that, in vision, we possess intermediary qualities, which link together the terms of the colour series, whereas mixed tastes have rather the character of perceptions than of pure sensations. But we find well-marked taste contrasts. The contrast-relations are, at present, perplexing: we cannot arrange the four qualities at the four corners of a quadrilateral, as we can R, Y, G and B in the colour pyramid. On the other hand, very little experimental work upon taste has as yet been done; and we may be sure that the contrast-laws will some day submit themselves to a formula. The problem is incomparably easier than it was in the case of sight.

It may be added that the taste-cells of a single papilla respond in the majority of cases to more than one of the four adequate stimuli, while the anatomists have not discovered any structural difference between the cells of one beaker and those of another. This sameness of end-organs may also be taken to indicate singleness of sense.

On the part played by smell in ordinary 'tasting,' see below, p. 71.

It must not be forgotten that the tongue is sensitive, not only to taste, but also to pressure, temperature and pain, and that it is, further, an organ of extreme motility. If wine tasting is principally a matter of smell, tea and coffee tasting are matters that depend in large measure upon tactual elements.

EXPERIMENT XIV

§ 24. **The Distribution of Taste Sensitivity over the Tongue: Taste Reactions of Single Papillæ.**—In this experiment we stimulate separate 'fungiform papillæ,' in order to determine whether each papilla is like all the rest, *i.e.*, whether all alike furnish all four of the possible taste sensations, or whether there are local differences of sensitivity (as there were, *e.g.*, in the case of the skin). The papillæ in question are recognisable as clearer, darker and redder spots, set in the opaque pinkish 'skin' of the tongue. They are usually less than 0.5 mm., but may be as much as 1.5 mm. in diameter. They are found in groups at the tip of the tongue; scattered along its sides; at the back, just in front of the circumvallate papillæ; and here and there over the median surface. Those at the back are not easily accessible, and those dotted over the middle portion of the organ are either insensitive or at best but very slightly sensitive to taste: we therefore work with the papillæ of tip and sides. Each papilla carries a number of taste-beakers, clusters of taste-cells and supporting cells, which constitute the specific end-organs of taste. We cannot then, in this experiment, stimulate a single end-organ, as we could a single pressure or temperature spot; we must be content to apply the stimulus to a single papilla. The method is less refined, and our results will be less clear-cut than in Exp. X.

MATERIALS.—Biconvex lens, held in stand, vertically adjustable. Five fine camel's-hair brushes, trimmed even at the point. Cotton wool. Two sets of solutions, weak and strong, in wide-mouthed bottles:

	Weak.	Strong.
Sugar	20%	40%
Salt	2%	Sat. sol.
Tartaric Acid5%	8%
Hydrochlorate of Quinine002%	2%

Distilled water, in similar bottle. Glass of distilled water, for washing brushes. Caraffe of distilled water, and glass, for washing mouth. Pan to take mouth rinsings.

PRELIMINARIES. — *E* and *O* are seated on opposite sides of a bench or narrow table, the lens between them. *O* puts out the tongue, flattening it over the lower lip and holding it as steady as possible. *E* adjusts the lens to give a clear magnified image of the exposed tongue. He then makes a rough map of it, marking contour and median lines, and putting in a few characteristic and easily recognisable groups of fungiform papillæ. Five individual papillæ, chosen from among these groups by their greater size and deeper colour, are localised very carefully upon the map, and numbered. These are the papillæ whose function is to be determined.

EXPERIMENT (1). *Strong Solutions.* — *O* plugs his nostrils with cotton wool, closes his eyes, and takes up a comfortable position in readiness for *E*'s signal. *E* takes a brush from the water; dries it with cotton wool; and dips it two or three times in the solution which he intends to use. At the word "Now!" *O* dries his tongue by squeezing it against the roof of his mouth, and then extends it. *E* sets the brush down gently and evenly upon the chosen papilla, being careful that the solution does not run. The brush may be held in place 2 to 3 sec., or until such time as *O*, having cognised the taste, withdraws his tongue.

O gives the result of his introspection, which *E* records. *O* washes his mouth out thoroughly with water, and *E* replaces the used brush in water. After an interval of 2 to 3 min., a second papilla is stimulated either with the same or with a different solution; and so on, until all five papillæ have been once stimulated.

After a pause of at least 5 min., a second series may be begun. The five papillæ are stimulated over again, but in a different order, with solutions which may be either different from or the same as those with which they were stimulated before. It is important that *O* shall have as indefinite an idea as may be, both (1) as to the papilla which is under stimulation, and (2) as to the stimulus which is being applied. To ensure this result, the solutions are applied in irregular order; the papillæ taken in

irregular order; and occasionally a papilla is stimulated with distilled water,—this being taken from a bottle of the same appearance as the others, and therefore unrecognisable by *O* even if he observe the dipping of the brush into the bottles.

The series should be continued, until each papilla has been stimulated 5 times over by each solution, irrespective of the applications of distilled water.

(2) *Weak Solutions*.—The experiment should be repeated, with the same papillæ, but with the weak instead of the strong solutions.

RESULTS.—*E* throws the results of *O*'s introspections into tabular form. In the extreme left-hand column is placed the number of the stimulated papilla, and in five succeeding columns the results of its stimulation by sugar, salt, acid, quinine and water. The sign ++ may be used to denote 'very strong and clear sensation' (thus, ++ under the heading 'sweet' would mean that the papilla in question gave a clear, strong and unmistakable sweet sensation); + to denote a clear but less intensive sensation; — to denote the absence of any sensation; and ? to denote a doubtful or indefinite result. If a stimulus is sensed, but not sensed in kind (if, *e.g.*, sugar evokes a sensation of 'salty'), the name of the sensation aroused must be entered in the Table.

The following Questions arise.

E (1) Is there any evidence in the results that the papillæ are selective or specific in function?

E (2) Are the confusions of one taste with another made at haphazard, or is there some degree of uniformity in *O*'s substitutions?

E and *O* (3) Is the fungiform papilla capable of furnishing any other sensations than those of taste?

O (4) Are all four tastes set up with the same rapidity?

O (5) What disturbing influences enter into these experiments, making the introspective judgments uncertain?

E and *O* (6) What further experiments, of the same kind, can you suggest?

EXPERIMENT XV

§ 25. **The Number of Discriminable Taste Qualities.**—In the preceding experiment we have taken it for granted that a fungiform papilla, if sensitive to taste at all, must be sensitive to some or all of the four qualities, sweet, bitter, sour, salt, and cannot furnish any other taste quality. Now that we are familiar with the method of stimulation of single papillæ, we may test this assumption. Is it true that the tastes named are the only tastes procurable from the tongue?

MATERIALS.—Lens, brushes, distilled water, vessels, as before. Series of ten taste-solutions in narrow-mouthed bottles.

EXPERIMENT.—All arrangements are made as in the preceding experiment, and the same five papillæ may be worked upon. Each papilla is stimulated, in random order, by each solution, also given in random order. The entire series should be repeated, with variations of order, three times over: so that each of the 5 papillæ is stimulated 3 times by each of the 10 'tastes' (150 separate tests). The only difference between this and the foregoing experiment, in procedure, is that *O* must in every case record the results of his introspection before he withdraws his tongue. Blank experiments, with water as stimulus, may be introduced if need arise.

RESULTS.—*E* should draw up three preliminary Tables, showing the facts obtained in the three separate series of experiments (order in which solutions were given, order in which papillæ were stimulated, *O*'s introspective records). He should then combine these into a total Table, showing simply the reaction of each papilla to each solution, irrespective of order.

The following Questions arise.

O (1) Is there any indication of taste sensations other than the familiar four?

E and *O* (2) Why must the haphazard order of experimentation be so strictly adhered to?

E and *O* (3) Why must *O* record his judgment before withdrawing his tongue?

E (4) Is there any special reason for keeping *O* in ignorance of the stimuli used in this experiment?

EXPERIMENT XVI

§ 26. **Taste Contrasts.** — The object of this experiment is to ascertain the existence of contrasts of taste quality; *i.e.*, to discover whether and in what way the stimulation of the tongue by a taste stimulus of one quality increases our sensitivity to tastes of other qualities. It may be said beforehand that taste contrasts exist, but that they do not obtain between all the taste qualities alike. We shall work with the two qualities ‘sweet’ and ‘salt,’ without asserting that these qualities do or do not contrast.

MATERIALS. — Two 20 cc. pipettes, graduated in .1 cc. Caraffe of distilled water, and glass; brushes; vessel to take mouth rinsings; cotton wool. Set of solutions, in wide-mouthed bottles, as follows:

Standard solutions	sugar, 30%; salt, 50% of sat. sol.
Subliminal “	“ 1%; “ .5% “ “
Weak “	“ 5%; “ 5% “ “
Distilled water.		

PRELIMINARIES. — *E* must assure himself that the ‘subliminal’ solutions really are subliminal for *O*, — that there is no suspicion of sweetness in the 1% sugar, and none of salt in the .5% salt. If necessary, the solutions must be weakened before the experiment begins. *O* works with stopped nostrils and closed eyes.

EXPERIMENT (1). *Contrast induced by sugar.* — *E* puts 2 to 4 cc. of standard sugar in the one pipette, and the same amount of water, or .5% salt or 5% salt in the other. *O* dries and extends his tongue. *E* takes the two pipettes in his two hands, and brings them into position over the two sides of the tongue, near the edge. He lets drop, as nearly as may be simultaneously, .2 to .3 cc. of the liquid of each pipette, — taking great care that the flow is steady, and that neither liquid extends across the median line to mingle with the other. *O* states the nature of the sensation aroused by the weaker stimulus (the water or salt solution).

After an interval of two to three min., during which *O* has very thoroughly cleansed his mouth, another test is taken. The standard sugar is applied to the side of the tongue which pre-

viously received the weaker stimulus, and *vice versa*. — This procedure is continued until each side has received all four possible stimuli (standard inducing solution, two weaker solutions of opposite quality, and water) three times over (18 separate tests).

(2) *Contrast induced by salt*. — The experiment is repeated, with standard salt for standard sugar, and with weaker sugar replacing weaker salt solutions.

RESULTS. — *E* throws the results of *O*'s introspections into tabular form.

The following Questions arise.

E (1) Do the results show evidence of contrast? Do you regard this contrast as a true taste phenomenon, or as merely due to suggestion?

E and *O* (2) Are the standard sugar and the standard salt equally powerful in inducing contrast?

E and *O* (3) What further experiments can you suggest, as likely to throw light upon the question of taste contrasts?

CHAPTER V

OLFACTORY SENSATION

§ 27. **Olfactory Sensation.**—The sense of smell is at a peculiar disadvantage as regards investigation. True, it is a peripheral sense; its organ is placed on the outside of the body. But we cannot explore the surface of this organ directly, as we can in the case of sight, taste, pressure, temperature and pain; nor have the sensations of smell been worked up into an artistic system, as have the sensations of tone in music, so that we might appeal to this and work back from it to the sensations themselves. We cannot do much more than proceed by analogy, following the methods that we have employed with good result in other sense departments, and hoping that they will do us the service here that they did us under more favourable conditions.

We shall naturally turn for assistance in the first place to the sense which is, in function, so nearly related to smell,—the sense of taste. We come at once, however, upon a difficulty. Taste has four qualities, and no more. Smell seems to have a very large number of qualities. Must not two senses, so different in their equipment, in the number of elements which they contribute to the make-up of mind, be very different in other respects?

It would be premature to say that this difficulty is merely imaginary. But we may reasonably doubt whether it is as formidable as it looks. For there is evidence that by far the great majority of odours are not elementary at all, but compound,—mental complexes, or ‘fusions,’ of the same sort as the note of a musical instrument, which is in reality a combination of a number of simple tones. And again: we have a method—laborious enough in its application, and as yet only very scappily applied, but still a method—which holds out good hope that we shall presently be able to reduce the number of smell qualities

to a comparatively small number: perhaps not to the four of taste, or the six of sight, but at any rate to a much smaller total than is suggested by ordinary experience.

This is, so far, encouraging. And encouragement comes from another source. While little progress has been made in the psychology of smell qualities, a good deal has been done towards the psychology of smell intensities. It has been found that intensive smell 'fusions' obey the same laws as do intensities of sensation in other fields. Various methods have been devised for the measurement of smell intensity, — the just noticeable smell, the just noticeable difference of smell, etc. We cannot deal with these questions here: but it is well to realise that they have been asked, and a good many of them answered.

PRELIMINARY EXERCISES. — It is very important to recognise clearly the wealth of smell and the poverty of taste, as given in our everyday experience. We saw in Exp. XV. that a large number of taste solutions might be applied to separate fungiform papillæ, but that all alike, if tasted, gave a sensation of sweet, sour, bitter or salt. We will now vary the experiment, bringing it nearer to the conditions of real life, in order to demonstrate what Ludwig called the 'unselfishness' of smell, — its self-sacrifice on behalf of taste. The greater part of what we eat is tasteless: our food gets its 'flavour' from scent and condiments.

MATERIALS. — Series of 8 tastes, as follows:

- (a) Sweets: honey, New Orleans molasses;
- (b) Bitters: strong coffee, tea not quite so strong as to be astringent;
- (c) Sours: lemon juice, cider vinegar, both diluted to lessen astringency;
- (d) Salts: clam bouillon, beef bouillon.

The bitters and salts should be warm, if possible.

Teaspoons. Cotton wool. Distilled water. Vessel to take mouth-rinsings.

EXPERIMENT (1). — *O* shuts his eyes. A teaspoonful of the various liquids, taken in haphazard order, is put into his mouth. He tries to identify the substance in each case, using taste and smell as in everyday life. After he has done so, he spits out the

stimulus liquid, and rinses his mouth thoroughly with water. — There will probably be no difficulty in naming the eight ‘tastes.’

The tastes are now taken in pairs: salts, sweets, etc. *O* sits with closed eyes and plugged nostrils. A teaspoonful, first of honey, *e.g.*, and then (after rinsing) of molasses, is put into his mouth, and he is required to identify them by taste alone. He must not breathe out during the stimulation. — The test is repeated with the two bitters, etc.

Is identification possible under these conditions?

(2) We see, then, that ‘tastes’ are, as a matter of fact, very largely taste-smell complexes. The converse of this fact appears in the names that we apply to smells proper. We are apt to name them after tastes; *i.e.*, there is likely to be an associative taste element in our apprehension of smell qualities. Thus the air in the neighbourhood of a sugar factory seems to ‘smell sweet,’ — though there is no such thing as a sweet smell; it is the taste of sugar that is sweet. Contents returned from the stomach by vomiting ‘smell sour,’ — though there is no such thing as a sour smell. The mass smells somewhat as acetic acid and curdled milk smell: and these things happen to *taste* sour. Hence the association.

To test the presence of this associative taste element in smells, give *O* a bit of baker’s chocolate and a little tincture of peppermint. How do they smell? They smell alike, and the word for this likeness is a taste word. Now let *O* taste them. Do they taste as they smelled?

(3) If time allow, *O* should be asked to classify a series of smells, on the basis of sense resemblance and not on that of affective value (pleasantness or unpleasantness). The scents should be in phials, of the same size and appearance, wrapped round with paper so that the colour of the contents cannot be seen, and numbered. Useful phials for this and the following experiments are the small stoppered sample bottles in use by druggists, about 6.5 cm. high and 12 mm. in inside diameter at the mouth. If the stimulus be a liquid, a few drops should be poured into a phial, and then a loose plug of cotton wool inserted; if it be a melted solid or a powder, rather more should be poured or shaken in, and then the cotton wool inserted as before.

The experiment should be performed in a leisurely way, as the nose is easily fatigued by smelling. Into how many groups or classes do these smells seem naturally to fall? Is *O* equally sure of the sense relationships within all his groups, or do some groups stand out markedly beside the rest?

EXPERIMENT XVII

§ 28. **The Field of Smell.** — Every one is familiar with the fact that, on a cold winter's day, the breath may be seen as a cloud of steam issuing from mouth and nose. If we sit in a cold room that is free from draughts, keep our head unmoved, and close our mouth, the steam-clouds take regular shape. They appear as two cones, having their vertices at the two nostrils. If, now, we could take a cross-section of the bases of these cones, at a known distance from the nostrils, we should obtain two roundish-oval areas, which would represent the portion of space covered by the exhaled breath. Or, since the difference between exhalation and inspiration in this regard is negligibly small, we should obtain the fields of inspiration, a map of that portion of space from which we draw air in breathing.

It is clear that the field of smell, the portion of space from which we draw olfactory stimuli that are effective in sensation, must stand in a definite relation to the field of inspiration. It cannot be larger than the breathing field. On the other hand, it may be coincident with the field of breathing: we may be able to smell all the scented air that we take in; or it may be smaller than the field of breathing: scents may be effective only over a certain circumscribed area within the base of each breathing cone. Our object, in the present experiment, is to map the fields of breathing and of smell, and so to decide which of these alternatives is correct.

MATERIALS. — Square of sheet tin, 14 by 14 cm. Head rest. Standard, with adjustable arm and clamp. Spirit level. Paraffin. Pan containing ice. Sponge. Black oil paint and camel's-hair brush. Chalk.

PRELIMINARIES. — *O* sits at a low narrow table or bench, his head adjusted to a comfortable position in the head rest. *E*, sitting on the opposite side of the table, smears the middle por-

tion of one of the edges of the tin square with paraffin. The wax should be spread widely enough to take the impression of *O*'s canines. The square is then clamped to the standard, which is placed to the right of *O*. The spirit level is laid upon the tin. *O* bites firmly into the paraffin; and, while he is holding it with his teeth, the tin square is brought to the right height, and the supporting arm turned until it lies evenly in the horizontal plane. *O*'s part in the experiment is then finished for the time being.

E draws chalk rings upon the floor round the legs of *O*'s chair, and upon the table round the support of the head rest and the feet of the standard. He carefully notes the height of the head rest and of the tin square above the table, etc. The outline of the clamp is painted upon the tin in black. The tin is then removed from the clamp, the wax cautiously pared away, and the outline of *O*'s teeth painted in a similar manner.

The apparatus can now be taken down, if need arise, without fear of error in its reconstruction.

EXPERIMENT (I). — *E* places the tin in position, and sponges its lower surface with ice water. When it has become sufficiently cool, *O* settles his head in the head rest, takes the tin between his teeth, and closes his lips and eyes.

O has now nothing to do but to breathe regularly and normally. At every expiration, clouds—the clouds that represent the breathing fields—form upon the surface of the cooled metal. *E* marks the outline of the two ovals, as accurately as possible, in black paint. The experiment must be continued until a satisfactory outline has been obtained. It may be necessary to interrupt the work, once or more, in order to cool the tin. The painting must be done quickly, since it is only in the first second or two that the breathing spots are true cross-sections of the breathing cones. The clouds very quickly evaporate along their edges.

At the moment of formation, the breathing spot is, so to speak, a 'solid' cloud. As evaporation begins, however, *E* will notice a cross-line, running obliquely inwards from anterior to posterior margin, and so dividing the spot into an anteromedian and a posterolateral portion. The borders of this line must also

be painted, and its width and direction verified in repeated trials.

RESULTS. — *E* has an accurate map of *O*'s field of breathing. The map consists of four irregularly shaped patches; the right and left pairs are roughly oval in form. We now proceed to compare the extent of this breathing field with the extent of the field of smell.

MATERIALS. — Architects' paper. Square of perforated tin, 14 by 14 cm. [The perforations in the tin should be 1 mm. in diameter, and neighbouring circles should be 1 mm. apart at their nearest points.] Needle and thread. Hypodermic syringe. Oil of cloves.

PRELIMINARIES. — A sheet of architects' paper is laid over the map of the preceding experiment, and the outlines of the breathing spots, the clamp, and *O*'s teeth carefully traced upon it. The paper is then cut to the size of the square, and sewed firmly to the perforated tin, which is to replace the sheet tin in what follows.

E takes up a few drops of oil of cloves in the syringe, — which must then be thoroughly cleaned on the outside, — and withdraws the piston to its full extent. The syringe is thus filled with air, heavily charged with the vapour of the oil.

EXPERIMENT (2). — The paper-covered tin is placed in the clamp. *O* bites into the margin, as before, closing his lips and eyes. *E* pushes the needle of the syringe through the paper, from below, at some point within the area of the breathing field, and says "Now!" He then presses the piston steadily upwards, through some 3 mm., while the mouth of the needle is at the level of the paper. After 2 sec. the syringe is withdrawn. *O*, as soon as he hears the ready-signal, sniffs very gently and evenly. If he smells the oil of cloves, during the 2 sec. interval, the pin-prick in the paper is marked by *E* with an ink cross; if he gets no sensation, the pin-prick is surrounded by an ink circle. If (as may happen) he seems to get 'something,' but cannot decide as to its quality, the pin-prick is marked with both cross and circle, and a special record of the introspection taken.

E works over, in this way, the surface of the four breathing patches, the surface of the three intervening areas, and a strip

about .5 cm. in width adjacent to the outer margins of the breathing spots.

RESULTS. — *E* has a map of the field of smell, laid over the map of the field of breathing. The following Questions arise.

O (1) Is the smell quality equally distinct at all parts of the field of smell?

E and *O* (2) What is the relation of the field of smell to the field of breathing?

E and *O* (3) Why is it necessary to set a time-limit (2 sec.) to the smell stimulation?

E and *O* (4) What are the principal sources of error in the experiment?

E and *O* (5) State, giving an explanatory diagram, the anatomical basis of the relation of the fields of breathing and of smell.

E and *O* (6) The field of smell, as mapped in this experiment, is rather surprisingly small. How do our experimental conditions differ from the conditions of olfaction in ordinary life?

EXPERIMENT XVIII

§ 29. **The Olfactory Qualities: Method of Exhaustion.** — We cannot lay the olfactory surface bare, and work over it with smell stimuli point by point, — as we can work over the skin with pressure stimuli. But let us suppose that the surface really is a mosaic of end-organs, attuned to different scents as the fungiform papillæ are attuned to different tastes, or the cutaneous 'spots' to pressure, warmth and cold. Is there no way of getting at the functions of these different organs, and so of determining the number and nature of the olfactory qualities?

We know that the nose is very easily fatigued. Let us, now, not only fatigue but actually exhaust the nose for a given odour; let us sniff at the substance until we can smell it no longer. On the assumption that there are different end-organs set in the olfactory mucous membrane, the odour in question will have exhausted some organs only, and left the rest (those to which it was not attuned) unwearied. Suppose, then, that after such exhaustion we sniff in quick succession at a number of other

odorous substances. If we cannot smell them, their odour must appeal to the exhausted end-organs; if we can, their odour must appeal to the unwearied. In the former case, the odours will be of the same quality (or belong to the same group of qualities) as the original fatiguing odour; in the latter, we are in presence of new qualities.

By continuing this method of elimination far enough, and using all the various odorous substances in turn as fatiguing odours, we should be able to determine the elementary, irreducible smell qualities: always on the assumption that there are specific end-organs of smell, of the sort indicated above. Indeed, we should in all probability not be obliged to work through the method to the bitter end; after we had gone some distance, the smells would tend to arrange themselves in natural groups, and we could make short cuts in our determinations.

The method has been tried, and promises to be successful; but it has not been carried very far. We will, however, verify the results hitherto obtained. First of all, we must familiarise ourselves with the phenomenon of exhaustion.

MATERIALS.—Set of odorous solutions, in similar phials. Cotton wool. Stop-watch.

EXPERIMENT (1).—*O* plugs one nostril (say, the left) with cotton wool. The plugging must be thorough. *E* lays the stop-watch on the table before him, and after a signal holds out an unstoppered phial to *O*, who brings it under his right nostril. The position of *O*'s head, and the distance of the phial from his nostril, should be kept as far as possible constant; though the experiment is too rough to require any very great precision. *O* breathes evenly and steadily, inspiring through the open nostril and exhaling only through the mouth. This latter rule is important. When exhaustion has set in—when the contents of the phial is no longer smelled—*O* returns the phial to *E*. *E* records the time that has elapsed between the first inhalation and the removal of the phial from the nostril.

Secondly, we may make use of the method of exhaustion to assure ourselves of the composite character of certain odours which seem simple at first smell. This experiment cannot be performed with any and every odour, but it can be performed

with a number sufficient to justify our working on the assumption of specific end-organs.

MATERIALS. — As before: except that the solutions are not the same.

EXPERIMENT (2). — We are now using scents which undergo a marked change of quality as the nose becomes exhausted. That is to say, the odours contain qualities which fatigue the nose with different degrees of rapidity. The experiment is, then, conducted as before: except that *O* indicates to *E* by a movement of the finger at what stages in the exhaustion-process such changes occur. *E* notes the times by the stop-watch.

We have now to enquire regarding the time of recuperation of the sense-organ, as we have enquired regarding its time of exhaustion.

MATERIALS. — Tincture of iodine; spirits of camphor. Stop-watch. Cotton wool.

EXPERIMENT (3). — *O* exhausts his nostril for the tincture of iodine. When exhaustion is complete, the stimulus is removed, and a pause of one min. is made. Then the iodine is again taken; the exhaustion period again determined; and another pause of one min. made. This procedure, of alternate exhaustion and one min. recuperation, is continued until the experiment reaches its natural end.

The experiment is repeated with spirits of camphor, except that the pauses are now of 2 min., instead of one min., duration.

Both tests are repeated, to ensure the obtaining of a typical exhaustion series. The results serve as a guide in the conduct of the next following experiment.

In this, we come upon our actual problem: the determination of the olfactory qualities by the exhaustion method.

MATERIALS. — Tincture of iodine, spirits of camphor. Set of solutions, in phials. Stop-watch. Cotton wool.

EXPERIMENT (4). — *E* selects five scents from the series. *O* familiarises himself with the odour of these, by inhaling each for a single breath, with four-breath intervals. After a 5 min. interval, *O* exhausts his nostril for iodine. When exhaustion has set in, he smells again at the five scents, in alternate breaths

(one inhalation, followed by a pause of one breath), and tells *E* in each case whether the odour is smelled strongly, faintly, or not at all. 'Strong' is, of course, a relative term, whose meaning is determined by the preliminary smelling. *E* enters these results in a Table.

At another sitting, five more scents are tried; and so on. — When the series has been completed with iodine exhaustion, it must be gone through again with camphor exhaustion.

Each of the full series should be taken three times over, in order to secure trustworthy results.

RESULTS. — *E* has (1) the exhaustion times for the substances used, (2) the exhaustion-analyses of the mixed scents, with time values, (3) the two recuperation series, and (4) a Table of qualities, classified as like or unlike by the exhaustion method. The following Questions arise.

E (1) What is the general result of exps. (1) and (3)? Is there any analogy to it in other sense departments? Can you explain it?

E and *O* (2) The 'mixed' smells of exp. (2) are spoken of as 'unitary.' Are there similar 'mixtures' in other sense departments, over and above the tonal fusions mentioned on p. 70? What form of connection among mental processes is the reverse of this 'fusion'? Give instances.

E and *O* (3) What general law can you derive from the results of exp. (4)?

EXPERIMENT XIX

§ 30. **The Olfactory Qualities: Compensations, Mixtures, Contrasts.** — (a) *Compensations.* — As there are certain visual qualities that are complementary or antagonistic, so there are certain smell qualities that are antagonistic, or, as it is more generally termed, compensatory. In other words, there are certain smells which, if given together, cancel or obliterate each other, so that no sensation is produced. This rule holds, even if the smell stimuli employed are of quite considerable intensity. We may prove it in two ways.

MATERIALS. — Double olfactometer, with cylinders. [This consists of a screen of odourless wood (cherry wood, well aired

and sunned, is good), 15 cm. broad by 10 cm. high, carried on a vertical rod for clamping to a standard, and pierced at the centre by two circular holes, 10 to 12 mm. in diameter and 18 to 20 mm. apart from centre to centre. Two hollow plugs of the same wood, turned in the shape of corks, pass easily into the openings and fit tight when pushed home. The bore of the plugs is 7 mm. Through plugs and screen are thrust two inhaling tubes: glass tubes, 5 mm. in bore, and 15 cm. in total length,—10 cm. projecting behind the screen, while the forward ends (1.5 cm.) are turned up at an angle of 40° to enter the nostrils. The tubes fit snugly into the plugs, and are further hindered from any chance

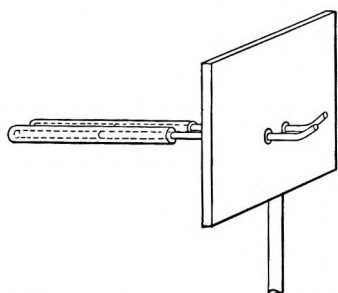

FIG. 14. — Double olfactometer. Chicago Lab. Supply Co., \$4.00.

slip by a little ridge of paper strips, fastened to the glass with gum arabic just in front of the forward edges of the plugs. The projecting lengths are graduated in 20 divisions of 5 mm. each. Over these pieces slide the odorous cylinders: hollow tubes of the fragrant material, 10 cm. long and 8 mm. in bore, themselves tightly encased in glass tubing (total diameter 14 to 16 mm.).

One end of each cylinder is sealed with paper, laid on with gum arabic,—a circular hole of 7.5 mm. diam. being punched in the centre of the paper cap, to allow air to be drawn into the inhaling tube when the cylinder is sliding over it.

Suppose, now, that a cylinder (say, of india rubber) has been slid over an inhaling tube to its full length, and that the bent-up part of this tube is inserted in the nostril. Nothing is smelled. The stream of air drawn into the nostril through the tube does not touch even the cut edge of the india rubber, since that is coated with paper. Now suppose that the cylinder is pushed one mark (5 mm.) off the tube. The air breathed in passes over the 5 mm. of exposed rubber-tubing surface before it enters the tube and so gets to the nose. If the cylinder is pushed out two marks, the stream of air passes over 10 mm. of the india rubber; and so on. It is thus possible to obtain a

number of smell stimuli, varying in intensity from zero to the strength of the full 10 cm. of stimulus surface.

If two qualitatively different cylinders are slid over the two inhaling tubes of the instrument, and these tubes thrust into the two nostrils, we get two simultaneous smell stimuli, of variable intensities.

The nine cylinders employed in the experiment have each a small paper label, marked with the letters A to H and K.]

Wooden clamp, for holding cylinders.

PRELIMINARIES. — The following are the rules for the use of the olfactometer.

(a) The inhaling tube should be thrust into the forward half of the nostril to the depth of 5 mm. If the tube presses against the back of the nostril, its scent will hardly be smelled at all, as the air current will take the direct path to the choana along the floor of the nasal cavity under the lower turbinal bone. Test this fact.

(b) The observer must discover for himself, by practice, the best rate and manner of breathing. Sniffing must be avoided. Expansion of the nostril reduces the intensity of the smell, because more air is taken in to dilute the odorous gas. Since the diffusion-rate within the cylinder is constant, an increased rapidity of breathing means dilution of the odorous substance with air: in other words, the more slowly one smells, within certain limits, the stronger will be the smell sensation. The air must be drawn in with sufficient force to send a part of the current above the lower turbinal bone. The observer must be trained never to breathe back into the inhaling tube.

In general, then, a quiet, steady, deep breathing, whose rate is self-regulated by the observer's comfort during the experiment, is the type to be aimed at.

(c) As the inhaling tube is breathed through, odorous particles will adhere to its sides. The effect of such adhesion, in the first one or two inspirations, is to reduce the intensity of the stimulus: the stimulus has lost so much of itself on the way. After this, the adhesion increases the intensity of stimulus: the odorous cylinder is, so to speak, continued into the inhaling tube, and the odour from the matter that has already adhered

more than compensates for the loss of strength due to that which continues to adhere.

It follows either that a large supply of tubes must be on hand for every experimental hour, or that the inhaling tube must be carefully washed and dried several times during an experimental sitting. On a damp day, in particular, the moisture left on the inside of a tube by the inspired air may be a very considerable source of error.

A keen lookout must be kept for evidence of the exhaustion error, which we have studied (for another purpose) in Exp. XVIII.

EXPERIMENT (I). — *E* removes one of the inhaling tubes from the instrument, so that this serves as a single olfactometer. He then takes the two cylinders marked A and K, and fits them end to end by the wooden clamp. The double cylinder is to be slipped over the tube, cylinder A going on first.

O sits at the table, and adjusts the olfactometer up and down its support till it is fixed at a comfortable height. The end of the inhaling tube is thrust into the right nostril, as directed above. The left nostril need not be plugged. *E* now slips the double cylinder over the tube, and *O* takes the handle of the clamp in his hand. The cylinders are pushed hard up to the screen, so that only cylinder K is smelled, and that in full intensity. *O* now moves the cylinders out, slowly and evenly, so that more and more of the smell of cylinder A can get to the nostril. Presently a point is reached at which the smell of this cylinder predominates, so that the original scent is lost. It is well to stop here, to note the point (so many mm. upon the inhaling tube) and allow *O* to rest.

After an interval of 1 to 3 min., the experiment is resumed. *O* moves the cylinders inward, starting from the point just fixed, very carefully and slowly, to see if he can find a point at which the two scents entirely cancel each other. If he goes too far, — if, *i.e.*, he passes through the point of compensation, and finds the smell of cylinder K coming to the front again, — he may push the cylinders outward a little; and so on, with a to-and-fro movement, until the compensation-point is either definitely found or definitely given up.

This test should be repeated three times, — at three different sittings. Similar tests should be made with the cylinders marked BK, CK, DK, the order being inner-outer in each pair.

EXPERIMENT (2).— We now pass to the use of the double olfactometer. The instrument is adjusted as before, and *E* places cylinder K on the one and cylinder E on the other inhaling tube. The former cylinder is held by the clamp, at the extremity of the inhaling tube, so that its full intensity comes to the nostril. The latter is pushed up against the screen, so that it is not smelled at all.

O takes the E cylinder in his hand, and moves it slowly and evenly outwards, until its scent becomes so strong as to predominate over that of K. A pause is then made, and the scale-mark of the E inhaling tube noted. After a rest, *O* moves the cylinder back, — if necessary, back and forth, — until the point of compensation is determined or the attempt to find it given up.

The test should be made twice for each nostril. Similar tests should be made with the cylinders marked ED, DC, E and D being the cylinders moved. Finally, tests may be made with the cylinders BF, GK and HK, *O* determining for himself which is to be moved and which to remain stationary at full strength.

RESULTS. — *E* has the scale-readings, and notes upon *O*'s introspections. The following Questions arise.

O (1) Do the experiments give evidence of compensation, — of the complete obliteration of scent by scent?

O (2) Do the experiments yield any evidence of smell mixture: *i.e.*, did the combined stimuli at any time give a third, novel smell quality?

E and *O* (3) What is the defect of the first of these two methods as compared with the second?

E and *O* (4) What conclusions, as to the specific energies of smell, can you draw from the results of the two experiments?

(*b*) *Mixtures*. — As certain visual qualities mix, to give a new quality, a quality which lies between the two primaries on the colour-cone, but is still itself simple, and different from either of them, so may smell qualities mix, to give a new 'mixed scent.' We have already seen (exp. (2), p. 78) that scents which seem to be simple at first smell may resolve into constituents in the

course of the exhaustion process. We have now to reverse this fact: to build up simple-smelling 'mixed scents' from known components.

MATERIALS. — Set of odorous solutions in phials. Small beakers, two sizes. Empty phials. Pipettes. Camel's-hair brushes.

PRELIMINARIES. — This experiment requires two rooms. The materials must be laid out in one room; *O* sits in another. The experiment may be performed in various ways.

EXPERIMENT (3). — (*a*) The simplest procedure is as follows. *O* smells separately the contents of two open phials. He then takes them together in his hand (not side by side, but the one before the other), and passes them slowly to and fro under his nose. He is to report whether, in the course of two or three inhalations, he gets the two original scents only, or gets a new third scent; and, in the latter event, whether the new scent is permanent, or present only from time to time, in flashes. (*b*) The same thing may be tried, with a phial held to each nostril. (*c*) Where the scents require to be taken in different proportions, a smaller beaker may be set within a larger, and a certain amount of liquid removed by pipettes from the two phials and dropped into the two beakers. The beakers are then taken in the hand, and smelled, as the two phials were. (*d*) If the amounts needed from two phials are very disproportionate, an empty phial should be taken, and some of the weaker-smelling liquid dropped into it, while a trace of the stronger is laid on the inner surface of the neck of the phial by a camel's-hair brush. The single phial is then smelled. — In every case the primary scents must be well known to *O* by previous smelling.

RESULTS. — *E* has the notes of *O*'s introspections. The following Questions arise.

O (1) Do the experiments give evidence of true mixture, — of the production of a new, simple quality from the combination of the two primary qualities?

O (2) If so, were the mixed scents all alike as regards stability and duration?

O (3) Do the experiments yield, on the other hand, any evidence of side-by-side persistence of qualities, of refusal to mix?

E and *O* (4) How should the experiment be carried out with the olfactometer?

(*c*) *Contrasts*. — We have already examined visual contrasts and taste contrasts. Arguing on these analogies, we shall expect that sensitivity to either one of the scents of a compensation-pair will be increased by previous stimulation with the other, whereas the sensitivity to any particular smell stimulus will not be increased by previous stimulation with a scent which is not antagonistic to it. Indeed, in the latter case, we may get an actual reduction of sensitivity by fatigue. Let us test these assumptions.

MATERIALS. — Double olfactometer, as before. Extra inhaling tubes. Set of cylinders, marked A, B, D, E, G, K, L, M.

PRELIMINARIES. — After the adjustment of the olfactometer by *O*, *E* places cylinder K upon an inhaling tube, pushing it hard up against the screen. *O* moves it out, carefully and slowly, until the rubber just begins to be smelled. This point is noted and recorded by *E*. After a rest (during which *E* cleans the tube, if necessary) the experiment is repeated. The same thing is done, until the point at which the rubber gives a liminal smell intensity becomes approximately constant.

E then takes *O*'s place. Or—and this is better, unless the change of seats and readjustment of the olfactometer are disturbing—*E* and *O* may take turn and turn about, from the beginning. Each records only the other's liminal tube-lengths.

The average liminal value obtained in these preliminary series gives us a norm or standard for the later work.

EXPERIMENT (4). — *E* places two cylinders, of which K is one, upon the olfactometer. The second is chosen at random, and is not known to *O*. Both are pushed up against the screen.

(*a*) *O* finds a liminal value for K. If this is done quickly and certainly, as it should be after the preliminary practice, the inhaling tube need not be changed.

(*b*) After a rest, *O* moves the unknown cylinder out, until its smell is quite distinct. He then runs this cylinder back to the screen, and takes (with the same nostril) the liminal value of K. — Plainly, if the unknown cylinder was a stimulus which compensates K, and if there really are smell contrasts, the K-limen

on this second trial will be smaller than that of (*a*). If the unknown cylinder does not compensate K, the K-limina should be approximately the same in both trials.

(*c*) While *O* is resting, *E* takes off the unknown cylinder, and puts another (also unknown to *O*) in its place, cleaning the inhaling tubes if necessary. When all is ready, *O* takes a K-limen, as before. That done, he takes the K-limen as affected by previous smelling of the other cylinder. *E* records the values obtained.

This procedure is continued until all the cylinders have been used (in irregular order, and always without *O*'s knowledge of what is coming) twice over. *E* then takes his turn as *O*.

RESULTS. — *E* has the liminal values, in mm., for the india rubber tubing (*a*) smelled alone, and (*b*) smelled after previous stimulation with other odorous substances. The following Questions arise.

E (1) Is there any evidence of smell contrast? Does the evidence tally with the results of the compensation experiments?

E and *O* (2) Can you suggest a better method for obtaining the limen?

E and *O* (3) Can you suggest any variation of procedure, on the lines of the compensation experiments?

CHAPTER VI

ORGANIC SENSATION

§ 31. **Organic Sensation.**—The organic sensations are given as fused complexes, whose constituent qualities emerge either not at all or only under very intensive stimulation. The problem is, therefore, in every case, to isolate each quality for itself; to eliminate all the members of the complex save one, and so to determine the character of the single component.

One of the most important of the organic complexes is the group of sensations, from muscle, sinew and joint-surface, which is brought into play by movement of the body or limbs. Experimental psychology, aided by pathology, has been markedly successful in the unravelling of the movement perception.

PRELIMINARY EXERCISES.—We are to deal, in Exp. XX., with the sensation of muscular contraction. It will be well to familiarise ourselves beforehand with the qualities of tendinous and of articular sensation.

(1) Clench the fist, and hold out the arm stiffly, as if you were supporting a heavy object. Or take a heavy weight in the hand, and let the arm hang down by the side. Note the sensation of strain (tendinous sensation) and its distribution.

(2) *Du Bois Reymond's Experiment.*—Take the two ends of a piece of elastic cord, say, 25 cm. in length, between the finger and thumb of the two hands. Draw the cord out, and relax it, three or four times over. Note that in the moment of relaxation you get a distinct push, as if the cord had become rigid (articular sensation).

QUESTIONS.—(1) Define organic sensation.

(2) Classify the organic sensations, giving the stimuli in each case.

(3) Estimate the part played by organic sensations in the mental life at large; in other words, indicate their place in a systematic psychology.

EXPERIMENT XX

§ 32. **The Sensation of Muscular Contraction.** — The object of this experiment is to isolate the specific muscular sensation; to identify the peculiar sensation quality that appears in consciousness when the sensory end-organs in striped muscle are stimulated.

MATERIALS. — Atomiser and ether. Weights. Arm-rest. Induction coil; wires; two electrodes; hot water; electric key; two Leclanché cells. [The *weights* consist of a hollow cylinder of soft wood, with closely fitting wooden cap, 12 cm. high and 5 cm. in outside diameter, lined on the bottom with chamois leather; a bag of shot which, together with the wooden box, weighs 100 gr.; and another bag of shot weighing alone 400 gr. The *arm-rest* should be solid, capable of adjustment in all directions by a ball and socket joint, and furnished with padded clips to hold the arm firmly in position. The best metal for the *electrodes* is brass, well nickel-plated. They may, however, be made in the laboratory, as follows. For the smaller, a disc of sheet tin, .5 cm. in diameter, is soldered to the end of a heavy copper wire, and covered with a moderately thick layer of soft sponge, the edges of which are tied to the wire with silk: if the wire is not insulated, a piece of rubber tubing slipped over it will serve as handle. For the larger, a piece of sheet tin, 4 by 5 cm., is covered with soft flannel, surrounded by a

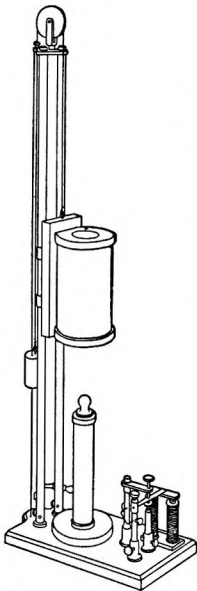

FIG. 15. — Upright inductorium of Du Bois Reymond. — Petzold, Mk. 120.

layer of fine linen; it is well to pierce the tin with rows of small holes, through which silk is threaded to hold the flannel and linen in place. Care must be taken that the metal does not come through its covering at any point. A stout wire is

soldered to the back of the tin plate as before. The ends of the wire handles are bent into loops, round which the wires used for connection to the secondary coil are twisted.]

PRELIMINARIES. — *O* bares his left arm from the shoulder down, and lays the fore-arm in supination upon the arm-rest. The height of *O*'s chair, or of the table upon which the arm-rest lies, and the position of the arm-rest itself, are carefully adjusted until an easy and comfortable position is obtained.

O closes his eyes. *E* puts the smaller bag of shot into the box, and stands this upon the broad part of *O*'s fore-arm, somewhat nearer the elbow than the wrist. *O* gives a full introspective account of all the cutaneous (and if there are any, of the subcutaneous) sensations set up by a 10 sec. pressure.

E puts the 400 gr. bag of shot into the box, and applies this as he did the smaller weight. *O* gives a similar account of the sensations aroused.

EXPERIMENT (1). — The portion of skin selected for the preliminary tests is sprayed with ether for 20 sec. The weighted box is then placed upon the skin for 10 sec., and *O* reports the sensations set up by it. The spraying and stimulation are repeated, until the cutaneous sensations have altogether disappeared. The experiment is continued for two or three sprayings beyond this stage, for the sake of exact introspection. Then the anæsthetised parts are allowed to recover. The stimulus is still applied, for the same periods and at the same intervals as before, that the gradual return of the lost sensations may be introspectively noted.

EXPERIMENT (2). — We now substitute stimulation by the constant current for mechanical application. The two cells are connected in series, through the key, to the two screws of the primary coil of the inductorium. The positive wire connects the secondary coil with the larger, and the negative wire with the smaller electrode. The former electrode is to be placed at the back of the neck, the latter on the fore-arm. The secondary coil is at a wide distance from the primary.

The skin of the back of *O*'s neck and the covering of the larger electrode are thoroughly moistened with hot water, and the electrode secured in position by a tape going round the neck.

The smaller electrode is to be tied upon the moistened skin of the fore-arm, over the motor point of flexion for, *e.g.*, the unguis phalanx of the second finger. The motor point should be localised, as accurately as possible, by reference to the diagram, and then found by actual experiment. The secondary coil is moved in until there is a sharp contraction of the finger at the break of the current.

The skin over the motor point is sprayed with ether until the cutaneous sensations have been wholly eliminated. The electrode is then tied in place, and *E* makes and breaks the current at the key. *O* closes his eyes, and reports the sensations aroused by muscular contraction.

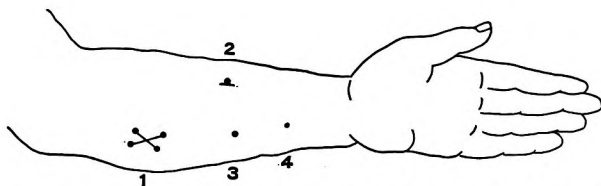

FIG. 16.— Motor points of the fore-arm (volar surface); W. Erb, Handbook of Electrotherapeutics [1883], 125. 1, flex. digitor. commun. profund.; 2, flex. digitor. sublim.; 3, flex. digit. sublim. (digit. II., III.); 4, flex. digit. sublim. (digit. indic. et min.).

EXPERIMENT (3).— Now that the muscular sensation has been isolated, we are in a position to recognise it in its usual complex setting. When the skin has fully recovered from the anæsthesia, *E* puts the box on the arm and presses it down heavily into the substance of the arm. The sensations set up are to be compared with those reported in experiment (2).

RESULTS.— *E* has *O*'s introspective reports. The following Questions arise.

O (1) Is there a specific muscular sensation? If there is, what known sensation does it most nearly resemble? Can you suggest any characteristic name for it?

E and *O* (2) Why do we use the induction coil in this experiment? Why do we not work directly from the cells?

CHAPTER VII

THE AFFECTIVE QUALITIES

§ 33. **Affection.**—When we set out upon our examination of Sensation, we left the question open whether or not there are any other kinds of elementary mental process (p. 3). Various candidates for this position have made their appearance in the different psychological systems. Only one of these has, however, been found worthy of serious consideration by experimental psychology. This is the affection, which professes to be the simplest characteristic process in feeling and emotion, as the sensation is the simplest characteristic process in perception and association of ideas. And even about affection there is wide difference of opinion: the whole psychology of feeling is still in a very unsettled state. The author inclines, at present, to the view (1) that affection is a conscious element, distinct from and ranged alongside of sensation in the composition of consciousness, and (2) that affection has two qualities only, those of pleasantness and unpleasantness. Reasons for this view will be found in his *Outline of Psychology*, 1899, 102 ff. It is the view upon which the following experiments are based. Should it prove to be erroneous, the experiments must be adjudged incomplete and imperfect; they would not, however, be wrong.

On the other hand, there are psychologists of high standing who hold the following, opposed opinions.

(1) Against the theory that affection is a conscious element, it is held:

(a) that affection is merely an attribute of sensation: sensations have, besides quality, intensity, etc., an 'affective tone';

(b) that affection is simply a closely welded complex of organic sensations; and

(c) that an affection is a reflexly-stimulated organic sensation: *i.e.*, that the process which under conscious stimulation appears

as organic sensation, appears under unconscious, reflex stimulation as an affection.

(2) Against the theory that there are but two qualities of affection, it is held that affection is a conscious element possessed of an immense variety of qualities,—as many as, or more than, the whole sum of sensation qualities put together. These qualities can be grouped in six great classes, as qualitative nuances of pleasantness-unpleasantness, tension-relaxation, excitement-tranquillisation.

In face of this divergence of expert opinion, it is plainly unwise to form a positive opinion of one's own. The student is advised, in approaching the following experiments, to take it for granted that affection is a separate process showing but two qualities; and to reserve his first-hand examination of the question until such time as he has attended a course of lectures upon Systematic Psychology.

EXPERIMENT XXI

§ 34. **The Affective Qualities : Method of Impression.** *Judgment by Paired Comparison.*—Our object, in this experiment, is to determine the relative affective value of coloured impressions. We have no absolute measure of the amount of pleasantness or unpleasantness that corresponds to a given stimulus; but we are able to say, when two stimuli are presented, which of them is the more and which the less pleasant. We shall work now with different colour-tones and different saturations of those tones.

In everyday life, we do not hesitate to say that we 'like' certain colours, and 'dislike' others. A good deal of this like and dislike, however, is due to 'association': what affects us is not so much the colour itself as the scene or incident which the colour suggests: we like colours that have played a part in agreeable situations, and dislike colours that have presented themselves under disagreeable circumstances. In the same way, we like a name, if we are fond of the person that bears it, and dislike the names of persons whom we dislike. With all this secondary or associative affective value we are now not concerned. But there is a good part of the like or dislike that is due to a direct affective reaction upon, or response to, the col-

oured impression itself. This direct value we shall determine, and express (relatively) in quantitative terms, in the present experiment.

MATERIALS. — Set of squares of coloured paper 4×4 cm. There should be (1) a set of 'standard' colours, containing at least R, O, Y, YG, G, BG, B, V and P, in the best possible saturation; and (2) a set of less saturated colours, one lighter ('tint') and one darker ('shade') than each of the standards.

Piece of neutral grey (or black, or white) cardboard, 20×20 cm., pierced in the middle by two windows, 3×3 cm. square and 8 cm. apart.

Cross-ruled paper.

PRELIMINARIES. — The experiment consists in the comparison of the affective value (pleasantness or unpleasantness) of every colour with that of every other colour in the series. As there are 27 colours in our supposed series, there will be $\frac{27 \cdot 26}{2 \cdot 1}$ or 351 separate comparisons to be made. In order not to waste time, we must work methodically, both in giving the stimuli and in recording *O*'s judgments.

(1) Lay the colours out, in spectral order, from R to P, placing always tint by tint and shade by shade (*e.g.*, RT, R, RS, OS, O, OT, YT, etc.). Number them in this order, 1 to 27. Construct upon the cross-ruled paper a Table like the following (carried out to 27 instead of only to 10 places):

Colour:	I	II	III	IV	V	VI	VII	VIII	IX
II	1								
III	2	3							
IV	18	4	5						
V	19	20	6	7					
VI	31	21	22	8	9				
VII	32	33	23	24	10	11			
VIII	40	34	35	25	26	12	13		
IX	41	42	36	37	27	28	14	15	
X	45	43	44	38	39	29	30	16	17

where the Roman numerals denote the colours, and the Arabic figures the number of the test. Note that each colour comes twice in succession: exp. 1, *e.g.*, compares I and II, exp. 2 com-

pares I and III, and so on. Take advantage of this fact to vary the position of each colour from experiment to experiment: let I be on the right in exp. 1, and on the left in exp. 2, etc., so as to avoid any possible space-error in the comparisons.

(2) Construct a similar, but blank Table, for the recording of judgments. Enter in it the number of the *preferred* colour in each test. Thus the following :

Colour:	I	II	III	IV	...
II	2				
III	1	2			
IV	1	2	4		
V	5	?	5	5	
:					

would mean that out of $\frac{5 \cdot 4}{2 \cdot 1}$ or 10 comparisons, I was preferred twice, II three times, III never, IV once, and V three times, while the judgment in the case of II *vs.* V was doubtful.

EXPERIMENT. — *O* sits at a table with closed eyes. *E* lays out colours I and II, and places the grey cardboard upon them. At the word of command, *O* opens his eyes, views the two coloured squares in the neutral frame, and gives an immediate decision as to which of them is the *more pleasant*. *E* enters the judgment in the Table; *O* closes his eyes and waits for the next test. *E* now lays papers I and III in the frame, and the experiment is repeated.

RESULTS. — *E* throws his tabulated results into the form of a curve, whose ordinates are measured by the number of preferences, and whose abscissæ are formed by the names of the colours, in spectral order. Where judgments of 'equal' or 'doubtful' occur in the Table, half a preference must be accorded to each of the compared colours, *i.e.*, the ordinates corresponding to them must be raised each by half an unit.

The following Questions arise.

E (1) Does the curve show any uniformity of preference, *e.g.*, preference for the colours at one end of the spectrum rather than for those at the other, preference for less or for more saturated colours, etc. ?

If so, then :

O (2) Can *O*, by introspection, without being shown his curves, name this preference, and roughly gauge the strength of it? Does the result of this general introspection square with the result of the experiment?

O (3) *O* had at first, in all probability, a good many *associations* with the colours. As the experiment and its method became familiar, these associations fell away, and the affective reaction was a reaction upon the bare sense impression. Was there noticed, over and above this direct affective value of the colours, any *emotive* value? Did the colours, *i.e.*, throw *O* into 'moods' or 'dispositions,' besides giving him a simple more or less of pleasantness?

E and *O* (4) Can you suggest any form of sense impression which is more likely to evoke a strong affective response than these colours? Give reasons (psychological reasons) for your answer.

EXPERIMENT XXII

§ 35. **The Affective Qualities : Method of Expression.** (1) *Involuntary Arm Movement as an Index of Pleasantness and Unpleasantness.*—In this and the following experiments we study the physiological symptoms or indications of the presence of an affective quality in consciousness. There are certain bodily 'expressions' of pleasantness, and certain others of unpleasantness. Our object is, then, to connect various forms and directions of bodily movement, registered by our apparatus, with the various kinds and degrees of affective process, as vouched for by introspection. And we begin by trying to discover how the involuntary tremor of the arm varies with variation of pleasantness and unpleasantness,—whether there is any general law of connection between the affective consciousness and this sort of bodily 'expression.'

MATERIALS.—Automatograph. [This consists of a light but strong board, 55 cm. long by 14 cm. wide, carrying at one end a small block of wood, 10 cm. in height and 8 in width, slightly hollowed out to take the elbow, and pierced at the other end by a circular hole, through which the stylus passes. The board is

slung in two loops of string, passing through screw-eyes on each side, and hooked together above for insertion in the

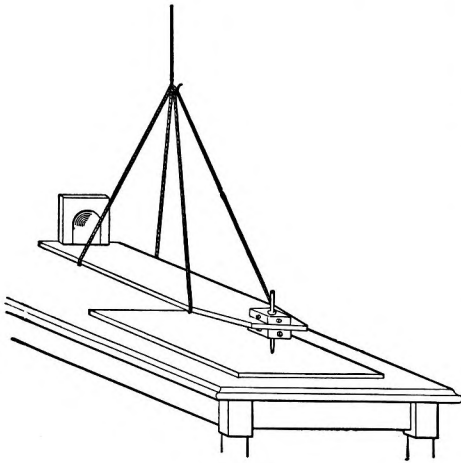

FIG. 17.

looped end of a strand of heavy wire, by which the whole apparatus is hung from the ceiling. The height of the board (its distance from the wire loop) can be regulated by passing the lower ends of the two string loops over any one of a number of screws, set in regular order on the lower surface of the board.

At the stylus end, the board carries, above and below, a block of

hard wood, 2 cm. high and 4 cm. square, through which (and the board itself) runs a circular hole of 1.5 cm. in diameter. The sides of each block are pierced by four screws, whose points project into the central opening, and serve as bearings for the stylus. This consists of a glass tube, about .5 cm. in diameter, weighted by a large wire nail or similar object, and drawn out below into a fine writing point. It must be so adjusted between the screw-points as to move freely up and down, but to have a minimum of play in the lateral directions. The stylus may be about 15 cm. in length.

On a table under the hanging board is placed a sheet of heavy glass, 60 by 25 cm. The surface of the glass may be about 8 cm. from the under surface of the board. Over the glass is spread a sheet of smoked paper, held in place by strips of lead or other weights along its edge. It is on this paper that the stylus writes. The table should be low: 65 cm. is a convenient height.]

Adjustable support, clamped to the table, and carrying a small tin dish which can be brought under *O*'s nose.

Set of 12 small tin dishes.

Set of 12 (six pleasant and six unpleasant) smell solutions or odorous substances.

PRELIMINARIES. — Let us suppose that *O* is to place his right arm in the automatograph. The stylus is removed; the instrument is allowed to come to rest; and the table is moved into such a position that the nearer edges of it and of the board are precisely parallel. *O* sits sidewise to the table, and slips his arm into the sling. The elbow is supported by the hollowed block; the hand rests, palm downwards, at the stylus end. The position must be entirely natural and comfortable. If there be any tilt in the board, from before backwards or *vice versa*, it must be removed (1) by a shift of the positions of *O* and table (coarse adjustment), and then (2) by a shift of the string loops over the screws below the board (fine adjustment). The board must lie evenly before an experiment is begun. Again: if there is any outward or inward turn of the board, — if the laying-on of the arm, despite the fact that the arm is quite slack, a mere dead weight, disturbs the parallelism of edges of board and table, — *O* must shift his position again: either the position of chair and table, or merely his own position in his chair. Everything must be square and true, and *O* must at the same time (as was said just now) be easy and comfortable.

Further: *O* must, at the beginning of every experiment, be in a 'normal,' *i.e.*, indifferent, frame of mind. It would plainly be absurd to arrange an experiment for the recording of the physiological response to pleasant and unpleasant stimuli, and then to select an *O* who was already affectively disposed (by the events of the day, by the trouble of the experiment, etc.) in a definite manner. If *O* is out of sorts, headachy, has a cold, has just received good or bad news, is particularly pleased with himself, — in all these cases, the experiment must be postponed.

EXPERIMENT (1). *The Normal Tremor*. — The first thing to do is to record the normal, indifferent movement of the arm. This tremor, due to the movements of breathing and other involuntary motor impulses, will serve as a standard with which we can compare the movements consequent upon pleasant and unpleasant stimulation.

O being in position, *E* lays the smoked paper on the glass. *O* closes his eyes, and, as far as possible, 'thinks of nothing.' That is, he lets his mind wander indifferently over indifferent topics, or lapses into a sleepy reverie. *E* lowers the stylus between its guides, and (when *O* is thoroughly settled) lets it slip down to touch the paper. The recording of the normal tremor may occupy 15 to 60 sec.; the time varies with the duration of *O*'s passive condition.

At the end of the 60 sec., or sooner if *O* has shown signs of distraction, *E* lifts the stylus from the paper, and *O* takes his arm from the sling. *O* declares, introspectively, whether the tracing is to be considered as a normal, or, if not, at what point (approximately) the disturbance which vitiated it began. *E* numbers the tracing, upon the paper; indicates by an arrow the direction (if there is any constant direction) which it followed; and readjusts the paper for a second experiment.

Six careful trials of this kind should be sufficient to establish the norm.

(2) *The Involuntary Movement as modified by Pleasant and Unpleasant Stimulation.* — All preliminary arrangements for experimentation are made as before. *E* adjusts the clamp, so that, when *O*'s head is in an unconstrained and natural position, the dish carried by it shall lie just beneath his nostrils. *O* closes his eyes, and the record of a normal tremor is begun. After 10 or 15 sec., however, *E* slips a dishful of odorous substance or liquid (pleasant or unpleasant, as the case may be) under *O*'s nose. *O* is allowed to take six inspirations of the odour, the stylus meanwhile registering his arm movement. At the close of the sixth expiration, *E* lifts the stylus from the paper, and the experiment is finished. *O* must on no account look at his tracing. *E* numbers the record, and indicates the direction (if there is a constant direction) of the movement.

The success of the experiment depends upon the affective value of the stimulus employed. If *O* declares that the odour was simply "a trifle unpleasant; but not bad," or "pretty good; but I didn't care much about it," we shall not obtain the affective reaction which we are seeking. Each stimulus must be

very distinctly pleasant or very distinctly unpleasant, if a definite result is to be secured. Moreover: *O*'s attitude to the stimulus is important. He must not be led off by the odour into a train of association, — speculating what the substance is, thinking of things that it reminds him of, pitying himself for being exposed to such nauseating stuff, — but must just, for the time being, *live* the odour: his consciousness must be a smell-consciousness, pure and simple. He is as passive as before: only, whereas he was formerly passive in a scatter-brained, dreaming way, he is now passive in a concentrated, absorbed fashion. If these directions are properly followed (and there is no serious difficulty in following them), twelve tests, six pleasant and six unpleasant, will be enough.

We have learned from Exp. XIX. that the scent phials must be kept in a different room from that in which the experiment is performed, and that ample time must be left, between test and test, for *O* to get rid of foregone smell sensations. These precautions are essential in the present experiment, where strong and insistent smells are employed.

RESULTS. — *E* has eighteen records, which may be regarded as reliable indications of affective consciousness: six with an introspective label 'quite indifferent,' six with the label 'extremely pleasant' (or its equivalent), and six with the label 'decidedly unpleasant' (or its equivalent). He has, further, a number of unsuccessful records: tracings with the label 'began normal; soon distracted,' and tracings labelled 'slightly pleasant' or 'weakly unpleasant.' All the tracings, after varnishing, must be cut out and pasted in the note-book.

The following Questions arise.

E (1) Is there any definite correlation between the tracings and the introspective records? If so, how is it to be formulated?

E and *O* (2) Can you suggest any biological reason for the correlation, if found, being as it is?

O (3) Which are the stronger affections, in this experiment: the pleasanths or the unpleasanths?

E and *O* (4) How could associations alter the tracing, if they did not alter the affective side of consciousness?

EXPERIMENT XXIII

§ 36. **The Affective Qualities : Method of Expression.** (2) *Muscular Strength as an Index of Pleasantness and Unpleasantness.* — This experiment has the same object as the preceding. In place of involuntary arm movement, however, we work with voluntary pull, from the wrist, upon the handle of a dynamometer. We have to see whether the amount of pull, measured in kg., varies with variation of the affective consciousness.

MATERIALS. — Finger dynamometer. [This consists of a Chatillon spring balance, reading in $\frac{1}{10}$ kg. units to 15 kg. The

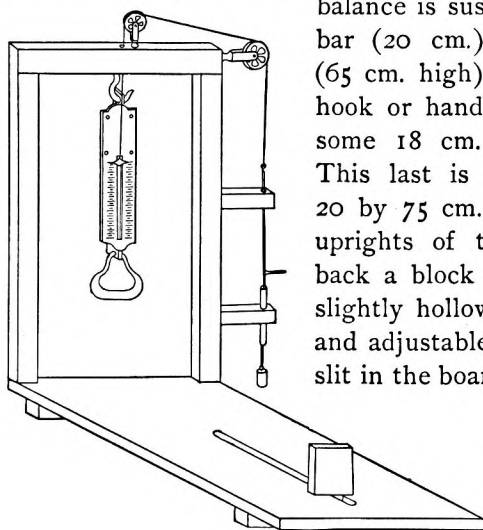

FIG. 18.

balance is suspended from the cross-bar (20 cm.) of an upright frame (65 cm. high) in such a way that its hook or handle hangs at a height of some 18 cm. above the arm-board. This last is a strong board, about 20 by 75 cm., carrying in front the uprights of the frame, and at the back a block of wood, 10 by 8 cm., slightly hollowed to take the elbow, and adjustable (by a set-screw and a slit in the board) to any length of arm.

The hook of the balance should be bent into triangular form, and padded, so that two fingers can pull upon it without dis-

comfort. A stop-watch hangs beside the balance from the cross-bar of the frame.]

Three hard-rubber syringes, each containing a table-spoonful of a taste stimulus.

Set of pleasant and unpleasant tastes.

Caraffe of distilled water and glass; vessel to take mouth rinsings.

PRELIMINARIES. — It is well to give *O* a little practice with the instrument before an actual experiment is taken. The right arm

is laid upon the arm-board, the edge of which is flush with the edge of the low table. *O* shifts his chair to and fro along the side of the table, until the elbow rests comfortably in the hollow block. He then lays his fore and second fingers in the dynamometer handle, thus bringing the arm into strong (but on no account painful!) extension at the wrist-joint. The pull is to be exerted in this position; *i.e.*, is to consist in an effort to flex the hand, without movement of the fore-arm above the wrist. There will be a tendency to bring the muscles of the upper arm and shoulder, perhaps even of the whole of the right side of the body, into play; but a little practice in taking up the proper position to the instrument will serve to correct it. There may also be a tendency to pull obliquely, instead of vertically down; or to thrust the hand out, forwards, instead of keeping it at its original distance from the body. In either case, the pointer-bar will bind in its bearings, and consequently the kg. readings will be vitiated by an objective source of error. Practice, again, will overcome the difficulty.

O's disposition must be favourable, as for Exp. XXII.

EXPERIMENT (I). *The Normal Curve*.—The first thing to do is to record the result of pulling, for a given period of time, under normal or indifferent conditions. *O* lays his arm on the board, and his fingers over the hook, and, at the word of command, pulls down with all his strength. This maximal effort is to be continued for 60 to 90 sec. *O* keeps his eyes and attention fixed upon the pointer of the balance, and is thus continually spurred on, by sight of its gradual rise, to exert the full power of his muscles. He tries, in other words, to hold the pointer continuously at the limit of maximal pull. *E*, seated at the other side of the instrument, reads off from the scale of the balance the position which the pointer has taken after the lapse of every 5 sec. His readings may, without difficulty, be made accurate to $\frac{1}{5}$ kg. At the end of the experiment, therefore, he has 12 or 18 kg. values, coordinate with the time values. *O*'s performance can be platted in the form of a curve, whose ordinates are kg., and whose abscissæ are the 5 sec. intervals.

There should be no localised pain, whether in wrist or fingers,

during the experiment. There will, naturally, be an increasing fatigue.

(2) *The Curve as modified by Pleasant and Unpleasant Stimulation.* — All preliminaries are as before, except that the tube of one of the filled syringes is inserted from the side into *O*'s mouth. Care must be taken that *O* is not disturbed by the position of the tube; if it is thrust in too far, *e.g.*, there will be a slight tendency to the vomiting reflex. But an indifferent position can always be found.

The experiment starts as before. At the end of 30 sec., however, *E* squeezes the bulb of the syringe (evenly and steadily, not with a jerk), so that *O*'s mouth is filled with the pleasant or unpleasant liquid. Records are taken for another 30 or 60 sec., as the case may warrant, and the total curve is platted as before.

This experiment must be repeated until *E* has records of three *very* pleasant and three *very* unpleasant stimulations (cf. Exp. XXII.). In order to avoid possible effects of 'suggestion,' a syringe may be filled with distilled water, of about 38°C. temperature, and *O* once in a while subjected to this neutral stimulus, instead of to a taste solution.

RESULTS. — *E* has some 15 curves: 3 normals, 3 very pleasant, 3 very unpleasant, and about half-a-dozen 'blank' (distilled water) curves and 'bad' records. Along with these go *O*'s introspections.

The following Questions arise.

E (1) Is there any definite correlation between the form of the curves and the introspective records? If so, how is it to be formulated?

E and *O* (2) Can you suggest any biological reason for the correlation, if found, being as it is?

O (3) Which were the stronger affections of the experiment, the pleasant or the unpleasant? If either, then:

E (4) Can this difference of affective intensity be read off from the curves?

O (5) What is the chief subjective source of error in this experiment?

EXPERIMENT XXIV

§ 37. **The Affective Qualities: Method of Expression.** (3) *Bodily Volume as an Index of Pleasantness and Unpleasantness.*— We find, in this experiment, that the volume of the hand and lower fore-arm varies with variation of the affective consciousness.

MATERIALS.—Plethysmograph. [F. Franck's plethysmograph (Gk. *πληθυσμός*, enlargement, and *γράφειν*, to write) consists of a round glass jar, 20 cm. high and 12 cm. in inside diameter. A turned wooden bar, held in place by cork ends, fits across the jar at about 6 cm. from the bottom: this serves as a handle, to be lightly grasped by the fingers when the arm is in position. Across the mouth of the jar is stretched a cap of heavy india-rubber sheeting, pierced by two openings. The larger of these, 5 cm. in diameter, receives the hand: its edge is continuous with a rubber sleeve, 6 cm. long, which extends down into the jar, and fits closely about the fore-arm of the subject. The smaller is continuous outwards with the bore of a short piece of rubber tubing, which in turn carries a glass tube, about 12 cm. in length, expanded midway into a hollow sphere of some 4 cm. diameter. From the further end of this glass tube a piece of rubber tubing runs to an air-cock, and thence to the tubule of a Marey tambour. The mouth of the jar is covered, above the rubber sheeting, by a disc of metal, pierced with circular holes corresponding to the wrist-opening and tube-continuation of the rubber. The disc is slit along its diameter, at the one end of which is a hinge, and at the other a catch; on its under side it carries clips that lock over the projecting glass rim.]

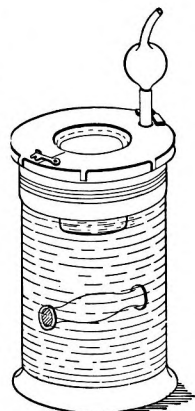

FIG. 19. — Franck's plethysmograph (Verdin, Fr. 30).

Vaseline. Lukewarm water. Set of pleasant and unpleasant stimuli.

Recording apparatus: kymograph and accessories, Marey tambour with writing-point, time-marker.

Adjustable high chair.

PRELIMINARIES. — *O* must become thoroughly used to the 'feel' of the instrument, before experiments are taken.

O bares his left arm, taking care that the rolled-up sleeves do not bind above the elbow. The hand and the fore-arm, up to about half its length, must be smeared pretty thickly with vaseline. *E* breaks the tubing connections of the apparatus at the far end of the glass tube,—so that the plethysmograph is freed, as in Fig. 19. He fills the jar almost to the top, with water of a temperature of 35° or 36° C. *O* forces his hand

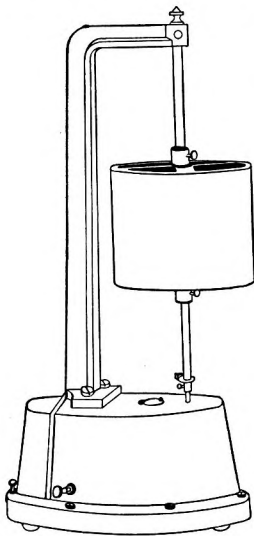

FIG. 20. — Kymograph. Chicago Lab. Supply Co., \$35.

gently down into the rubber sleeve, *E* holding the edges of the rubber sheeting to prevent a split. The hand is pushed in till the fingers can be clasped easily and comfortably round the wooden bar. Water is, of course, being pushed out at the end of the glass tube, and must be caught in a beaker or on a towel: it is, however, better to have too much than too little, as there must be no air-bubbles in the system,—and if air gets in, under the rubber sheeting, it is exceedingly difficult to drive it out again. When the hand is well in place, the metal cap is fitted over the mouth of the jar, and its fastening snapped. The plethysmograph should now be gently tilted, and the superfluous water allowed to run out: the water-level must stand about

half-way up the hollow glass sphere, when the instrument is vertical. The plethysmograph is then ready for connection to the tambour.

The high chair is placed at the side of a table, upon which the recording apparatus has been set up. *O* seats himself in the chair, locking the seat at such a height that his left arm hangs down comfortably while the plethysmograph stands upon the table. He sits passively, with closed eyes; *E* makes the required connections and adjustments. The clock-work of the kymograph is wound up, and the drum swung round to its

proper starting-point; the two writing-points are laid on, and their tangential position tested; the air-cock is opened, and the glass tube of the plethysmograph connected with the rubber tubing; the air-cock is then closed, and the rubber tubing laid over the arm of a standard so that there shall be no kinks or bends; the tambour writing-point (now moving) is raised or lowered as seems necessary. An experiment may then be taken.

EXPERIMENT (1). *The Normal Curve.* — *E* starts the drum, with or without a previous signal to *O*, and the tambour pointer begins to record the curve of normal volume. This curve is not a straight line, but a succession of slow rises and falls (breathing) notched by smaller rises and falls (pulse). If *O*'s disposition be even and indifferent throughout the test, the height of the curve above the time-line will remain constant.

When the drum has come round again to its starting-point, *E* arrests its movement, moves back the standards that carry the writing-points, and opens the air-cock. He then receives from *O* (who still has his eyes closed) a full introspective record of the course of the experiment. If *O*'s account is inadequate, he must try by judicious questioning and reminder to get an explanation of any irregularities that the curve may present.

There is no reason why the first curve taken should not be a satisfactory normal. If it is, and if *O* is not tired, and his arm not numbed by a constrained position or cold from the cooling of the water in the jar, *E* may proceed at once to the next experiment. If the curve is unsatisfactory, the cause of the failure should be noted, and the first experiment repeated. It is imperative that a good normal curve be obtained before the affective curves are attempted.

(2) *The Curve as modified by Pleasant and Unpleasant Stimulation.* — All preliminaries are as before, except that *E* has made preparations for giving *O* some pleasant or unpleasant stimulus. The drum starts, with or without a previous signal to *O*. After the third or fourth breath, the stimulus is given, say, for three breaths. It is then removed, and the volume curve continued until the limit of the drum is reached.

E marks on the drum the moments at which the stimulus begins and ends. When the experiment is over, and the apparatus disconnected, *O* dictates a complete introspective record of the experimental consciousness. Interest centres, naturally, about the behaviour of the curve during and immediately after stimulation: but the remaining portions must not be neglected. If *O*'s account is inadequate, recourse must again be had to carefully chosen questions and suggestions.

It is well to interrupt the experiment after two curves have been taken, and to allow *O* to withdraw his arm from the plethysmograph. This rule should be followed on principle, whether the curves obtained are successful or unsuccessful.

Suppose, then, that the experiments just described have given the curve of normal volume, and the volume curve as affected by a distinct unpleasantness. *O* now withdraws his arm from the plethysmograph, and *E* takes his place as subject. The experiments are repeated, except that the new *O* does not know beforehand whether his second trial is to be unpleasant or pleasant. When the curves have been obtained, another exchange of places is made. This time, *O* must give a normal and a pleasant curve, as he gave the unpleasant curve at his first sitting. He is not to be told which of the two will be taken first. Finally, when these two curves have been recorded, the exchange of places is made for the third time.

Eight curves are thus available: two normals, a pleasant, and an unpleasant, for each *O*. It is well to record an affective curve and its accompanying normal on the same paper; so that the whole experiment fills four drum-strips, — two to be kept by each *O*. Before the strips are varnished, *E* should enter upon them the date, the name of *O*, the order of each curve in the experiment, and the nature of the modifying stimulus (if such stimulus was employed). The points at which the stimulus was presented and removed have been already marked.

The experiments may be repeated, with varying stimuli, as often as time allows.

RESULTS. — *E* has the curves (four, at least), and the records of *O*'s accompanying introspections. The following Questions arise.

E (1) Is there any definite correlation between the course of the curves and the course of pleasantness or unpleasantness as vouched for by introspection?

E and *O* (2) Can you suggest any biological reason for the correlation, if found?

E and *O* (3) Were the curves affected by any extraneous influences during the experiment? Do the introspective reports of such disturbances tally with the drum-records and with *E*'s observation of *O*?

E and *O* (4) Can you argue from the appearance of these curves to other possible correlations of bodily process and affective consciousness? What experiments should you consider advisable?

CHAPTER VIII

ATTENTION AND ACTION

EXPERIMENT XXV

§ 38. **Attention.**—The word ‘attention’ has been employed, in the history of psychology, to denote very different things. Attention has been regarded, at various times, as a peculiar power of capacity, the ‘faculty of concentration,’ the ability to restrict at will the field of consciousness; as a peculiar form of mental activity, an effort which one puts forth or an initiative which one takes, so contradistinguished from the passivity with which perceptions and ideas are received; as a state of the whole consciousness, a state of clear apprehension and of effective thought; as a feeling or emotion; and, finally, as a sensation-complex, running its course alongside of the other mental processes, perceptions, feelings, etc., of the attentive consciousness.

The reader will, probably, find himself in sympathy with all five views. And such sympathy is natural: for theories, however mistaken or inadequate, rest always upon some basis of fact, and we need not look far afield for facts which appear to support these different interpretations. When I am so deeply sunk in a scientific problem that I forget my headache, or fail to hear the dinner-bell, I seem, pretty clearly, to be exercising the power of concentration. When I force myself to go to work, in face of the temptation to finish an interesting novel, I seem to be exerting a spontaneous activity, to be myself determining my world rather than determined by it. When, again, I wish thoroughly to understand a thing, to make myself master of it, I give it my full attention: attention is, then, that state of consciousness, that degree of being-conscious, which guarantees the best results of mental labour. Once more: I attend to what appeals to me as interesting, and interest is an affective process.

Attentive persons, in general, are persons who take an interest in observation ; and it does not sound amiss, at first thought, to define attention as 'pleasure in observing.' Lastly, when I am trying to attend, I invariably find myself frowning, wrinkling my forehead, holding my breath, setting head and body in a definite and rigid attitude. All such sets and movements give rise to characteristic complexes of strain and pressure sensations. Why should not these sensations be what we call 'attention' ?

The appeal lies to introspection. And our rule must be here as it is elsewhere, that if the results of introspection come into conflict with our preconceived opinions, the opinions are to be given up. We must be on our guard against hasty introspection and biassed introspection ; the 'results of introspection' must be the best results obtainable by the introspective method : but the verdict of introspection, once delivered, must outweigh all the authority of the schools.

Now introspection knows nothing of 'powers' or 'faculties' or 'activities.' What introspection knows are (*a*) processes, simple and complex, (*b*) attributes of processes, (*c*) states of processes, and (*d*) modes of connection of processes. Under which of these four rubrics does attention fall ?

Suppose that we are intently following the course of a surgical operation, or a scientific lecture demonstration, or the repair of a damaged bicycle, or the working-out of the plot of a novel. It is evident, in the first place, that the events attended-to are the clearest and most distinct events in consciousness. It is evident, secondly, that the events attended-from — the behaviour of our companions in the operating theatre or lecture room, the other constructions or repairs going on in the machine shop, the work on our desk that is waiting to be done — are unclear and indistinct, relegated, as it were, to the background of consciousness. Thirdly, we accompany the stages in the occurrence that we are attending-to by the strains and relaxations, the long breaths and the holding of the breath, mentioned above. And fourthly, we are all the while 'interested' in the occurrence ; our consciousness is an affective consciousness. In short, then, attention is a *state* of consciousness ; manifesting itself outwardly in attitudes

and movements which, like other attitudes and movements, set up certain *sense-processes*; and intimately connected with the arousal of *affective processes*. We must examine it under all three headings.

Question (1) What is meant by the 'faculty' psychology? By whom was it overthrown? Why is it untenable?

(2) In what various senses has the term 'activity' been predicated of mind? Is its use justifiable?

(3) How does a 'state of consciousness' differ from a 'conscious process'?

A. Attention as a State of Consciousness.—The principal laws of attention, regarded as a state of consciousness, are as follows.

(1) The process (or complex of processes) attended-to becomes clearer and more distinct than the rest of consciousness. The processes attended-from are rendered less clear and distinct.

(2) Under certain conditions, the process attended-to becomes more intensive, as well as more clear and distinct.

(3) Under certain conditions, the process attended-to becomes more durable, as well as more clear and distinct.

(4) There are never more than two degrees of clearness and permanence observable in the processes of a given consciousness. The difference is maximal in the case of 'absorbed' attention, minimal in that of 'roving' attention.

(5) The state of attention is of comparatively short duration; or, as it is usually put, the attention fluctuates.

(6) The processes attended-to cannot exceed a certain proportion of the processes constituting the total consciousness; or, as it is usually put, the range of attention is limited.

(7) The process attended-to rises more quickly than other processes which enter consciousness simultaneously with it.

We must verify (or, rather, illustrate) these laws in detail.

EXPERIMENT (1). *First Law.*—Materials: puzzle pictures.

Find the concealed figures in the puzzle pictures. Note that, when once found, they force themselves persistently upon you; their outline seems to be more distinct than the other lines of the picture, and the 'sense' of the picture as a whole recedes into the background.

Question (4) Are there any experiments that you have already performed, or that have been mentioned during this Course, which illustrate the first law of attention?

(5) Can you suggest any experiment, to be performed entirely without apparatus, the result of which may serve as illustration of this first law?

EXPERIMENT (2). *Second Law.* — Materials: piano.

(a) Strike on the piano the chord here indicated, and hold the keys down while the tones ring off. When the sound is quite weak, single out by attention some one of the constituent tones. Is the selected tone intensified?



(b) Strike a low tone upon the piano keyboard. Single out by attention some one of the overtones. Is it intensified? Now attend to the fundamental. Is it intensified?

(c) Strike the chord *c-e-g* strongly upon the piano keyboard, directing the attention to the *c*. Is it intensified? Strike the chord again, directing the attention to the *e* or *g*. Is the tone attended-to intensified?

Question (6) What are the conditions under which the second law is valid?

(7) What are the conditions under which the third law is valid? Give instances.

(8) What arguments can you urge for and against the validity of the fourth law?

EXPERIMENT (3). *Fifth Law.* — Materials. Colour mixer with Masson disc. Kymograph and accessories. Time marker. Rubber bulb, connected by rubber tubing to a Marey tambour and writing-point. Head-rest. [The Masson disc is a disc of white cardboard, 20 cm. in diameter. Along one of its radii is drawn an interrupted black line of even thickness (width of line, 5 mm.; length of broken pieces, 5 mm.; length of white interspaces, 8 mm.; distance between central end of broken line and centre of disc, 17 mm.). When the disc is rotated, each portion of the interrupted line mixes with the white of the remaining surface to form a grey ring, and the rings grow whiter and whiter, *i.e.*, less and less distinct, towards the periphery.]

PRELIMINARIES. — The disc is set up in an uniform, not too bright light, over against the head-rest, and at a convenient distance (say, 2 m.) from it. The kymograph must be placed as far away from *O* as possible, to avoid distraction by the noise of the clockwork. If it stands in the same room, it should be placed behind *O*, and screened by a curtain of some thick stuff. It is, however, better to put it in another room: the handles of the door may be removed, and the rubber tubing carried through the hole. In this case, the two rooms should be connected by electric bells, in order that *E* may give *O* the ready signal, and the signal to cease work, by ringing. The wires from the mixer should also be carried into the room in which the kymograph stands, and be connected to a key which is under *E*'s control.

E adjusts the time marker and tambour lever to the drum surface. The rubber bulb lies on *O*'s table, beside the head-rest, convenient to *O*'s right hand.

EXPERIMENT. — *O* settles his head in the head-rest, and lays his hand comfortably on the table, the fore and middle fingers resting upon the bulb. His eyes are closed. *E* starts the mixer. At the "Now!" or the bell-ring, *O* fixates the outermost grey ring of the disc, *i.e.*, the outermost grey patch that he can perceive upon the white surface. As the grey fades or drops out of view, he presses the bulb: gently, if the grey fade slowly, sharply if it 'jerk' out of sight. As (or when) the grey returns, he relaxes the pressure. The curve of fluctuation is thus written, above the time line, upon the smoked paper of the kymograph.

The experiment is continued during a single revolution of the drum. At its conclusion, *E* adjusts the two writing levers at a higher or lower level, while *O* writes out his introspective account of the course of attention. A second experiment is then taken.

At least ten such experiments should be made.

RESULTS. — *E* has the kymograph records and *O*'s introspections. The following Questions arise.

E and *O* (9) What is the average duration of a complete 'wave' (rise to rise, or fall to fall) of the attention? What is its mean variation? What were the extreme (longest and shortest) times found?

E and *O* (10) What is the relation of the periods of disappearance to the periods of appearance of the grey? Why do we choose this minimal stimulus-difference for observation, instead of looking for the fluctuations in intensive stimuli which would naturally hold the attention?

O (11) What are the chief sources of error in the experiment?

E and *O* (12) What further experiments can you suggest?

E and *O* (13) What evidence can you bring that these fluctuations are really fluctuations of attention, and not, *e.g.*, merely indications of some fluctuation at the periphery?

EXPERIMENT (4). *Sixth Law.* — Materials. Tube of black pasteboard, or of blackened tin, 50 cm. in length and 4 cm. in diameter. Disc of heavy white cardboard, 25 cm. in radius, having a sector of 36° cut out to the depth of 10 cm. from the periphery. Sector of 36° concentric with the disc. White object-cards, 6×6 cm. Accommodation card. Standards for tube and object-card. Rotation apparatus for disc, connected by belt to electric or water motor.

[The accommodation card is an object-card, at the centre of which an A is drawn or printed. Clear apprehension of the A means that *O*'s eye is rightly accommodated for the following object-card.

The object-cards have a single row of figures, 1 mm. in width of line, and high enough to fill the exposure field. The number of figures in the row ranges from one, at the centre of the card, to the full number that the card can contain. Series of cards should be prepared: lines, semicircles, circles, squares, diamonds, pot-hooks and hangers are the simplest available figures. The series may be increased by turning the lines, semicircles, etc., at different angles.

The lower edge of the object-cards is turned up a little, to form a ledge upon which the accommodation card may rest.]

PRELIMINARIES. — The disc is set up, in the vertical position, upon the table at which *O* is to sit. It turns with the clock-hand, from left to right; the rate of revolution should be once in the 1 sec. The blackened tube is clamped to its standard, in the horizontal plane, at the height of the centre of the disc. It stands on the right hand side of the disc, so that objects seen

through it and through the open sector of the disc are exposed from above downwards. The mouth of the tube is brought close up to the surface of the disc, the movable sector of which is fastened behind the disc proper. A second standard, holding a vertical object-card, stands 10 cm. behind the disc, directly opposite the mouth of the tube. The card must be brightly and uniformly illuminated.

The periphery of the movable sector should be divided up into ten equal parts of 3.6° . Since the disc revolves once in the 1 sec., a single division requires 0.01 sec. to pass a given point, and twice this time to pass over a field which just fills it. The disc and sector together thus give us exposure times of 2, 4, 6, . . . 20 hundredths of a second. If the figures are not as high as the opening in the sector, these times must, of course, be modified.

EXPERIMENT. — *E* sets the disc for 0.02 sec. exposures, and clamps a one-figure object-card in place. He lays the accommodation card upon the other, and says "Now!" *O* looks through the tube at the disc, sees the A for 0.02 sec., and accommodates for it. As the disc turns, *E* draws away the accommodation card, and so exposes the object-card. When the open sector comes round again, *O* sees the figure for 0.02 sec. He will have no difficulty in grasping it: the physical and physiological conditions are favourable, and the object lies well within the range of attention. After this single stimulation, *O* removes his eye from the tube, and describes (or draws) what he has seen.

The experiment is repeated, with a two-figure card. Again, *O* has no difficulty in grasping the stimulus. Then come 3-, 4-, 5-, 6-figure cards, etc. At a certain point in the series *O* will be in doubt as to what he has seen during the 0.02 sec. When this point is reached, he keeps his eye at the tube, and views the card during 2, 3, etc., successive exposures. Presently there comes a point at which he cannot grasp the stimulus at all, no matter how often the stimulation is repeated. The number of figures that can just be grasped with repeated exposure corresponds to the maximal range of attention, and is therefore the number to be determined.

RESULTS. — *E* has his own record of stimuli and exposures, and *O*'s description of the objects seen. The following Questions arise.

E (14) What is the maximal range of attention, as indicated by this experiment?

E and *O* (15) What are the requirements of a good tachistoscope?

O (16) Is the serial exposure of the stimulus (from above downwards) in this experiment prejudicial to the results? In other words: would an instantaneous exposure be better?

E and *O* (17) What further experiments can you suggest?

EXPERIMENT (5). *Seventh Law.* — Materials: bell metronome.

(a) Set the metronome pendulum for a fairly rapid beat, *e.g.*, 144 or 152 strokes in the 1 min., and the bell for sounding at every sixth stroke. What time-relation does the ring bear to its corresponding stroke? Do the two fall together? Or does the ring come before or after the stroke? (b) Set the bell for sounding at every second stroke. How are the ring and its stroke heard? Is it possible by shift of attention to shift the apparent time-relation of the two simultaneous impressions?

Question *O* (18) What conclusion do you draw from these two observations?

E and *O* (19) Suggest further experiments.

In what precedes, we have used the language of everyday life as regards attention; we have spoken of 'singling out' an overtone 'by attention,' etc. There is not the least reason why we should not employ these terms. We can no more break free of idiom here than we can elsewhere. No one thinks it foolish to enquire at what time 'the sun rises' or 'sets'; and so no one need think it foolish to ask how many things we can 'attend-to' at once. It is perfectly easy, when the true relations of things are understood, to mean aright what we say wrongly, — what we say, *i.e.*, in the form of words dictated by an exploded theory.

At the same time, a wrong form of words is apt, when the understanding of the phenomena is new, to bring about a lapse into the old mode of thinking. It must never be forgotten that attention is *not* a faculty which the mind possesses, *not* an

activity of a substantialised 'consciousness,' but in essence a state of consciousness, a mode-of-existence of conscious processes. This view of attention will be confirmed by the answers to the following Questions.

Question (20) What are the conditions of passive attention? In other words: under what circumstances *must* we attend, whether we will or no? Explain the working of every condition that you mention.

B. The Sense-processes in Attention. — Question (21) Give a full introspective account of the sense-processes characteristic of (a) visual attention, (b) auditory attention, (c) oscillation of attention between sight and hearing, (d) cutaneous and (e) tactual or motor attention.

(22) We are able, while we fixate a point immediately before the eye, to attend to impressions which fall upon outlying parts of the retina. Here, then, there seems to be a dissociation of attention and strain-sensations: the sensations belong to the object fixated, the attention to the object seen in indirect vision. How do you explain the anomaly?

(23) Suppose that it were possible to measure the intensity of the strain-sensations in a given attentive consciousness. Would this intensity be also a measure of the degree of attention?

C. Attention and Affective Process. — It is generally admitted that there is an intimate connection between the state of attention and the process of pleasantness-unpleasantness. There is, on the other hand, a great divergence in the statement of this connection, and a not inconsiderable divergence of opinion regarding its nature. We must first of all, then, get a clear idea of what the different psychologists mean by their formulæ, and then choose that which seems to square best with the facts.

Question (24) Explain and criticise the following statements.

(a) "Attention is identical with interest, and interest is a feeling. That is all there is to say" (Stumpf).

(b) "The sense-feeling is the mode of reaction of apperception upon the sense-excitation" (Wundt).

(c) "We dissociate the elements of originally vague totals by attending to them. . . . But what determines which element we shall attend to first? . . . First, our practical or instinctive

interests; and, second, our æsthetic interests. . . . These æsthetic and practical interests, then, are the weightiest factors in making particular ingredients stand out in high relief" (James).

(*d*) "'Interest' is so constant a condition of the apperception of a particular conscious contents that it has often been identified with attention itself. . . . But we must evidently draw a sharp line of distinction between attention and the feelings" (Külpe).

(*e*) "Affection and attention are simply obverse and reverse of a single process" (Titchener).

(*f*) "'To attend' means 'to be ready for mental work.' . . . During the time of this preparedness other psychical states may be set up: *e.g.*, interest, — which, as a part-condition favourable to the accomplishment of work, may be present in consciousness both before and during its performance" (Höfler).

(*g*) "Objective interest has, in every sphere, a very great influence upon the direction of attention" (Helmholtz).

EXPERIMENT XXVI

§ 39. **The Simple Reaction.** — A 'reaction,' in the technical sense in which we are here employing the term, is a movement made in response to an external stimulus. A 'simple reaction' is a movement made in direct response to such a stimulus. In the reaction experiment, we subject *O* to a prearranged form of stimulation, *e.g.*, a flash of light, to which he has to reply by a prearranged movement, *e.g.*, a pressure of the forefinger of the right hand. The instruments used are of such a kind that we are able to measure the time elapsing between the giving of the sense-impression and the performance of the answering movement. This time is named the 'reaction time,' and, if the movement is one of direct response, the 'simple reaction time.'

There are two sides, then, to the reaction experiment. On the one hand, *E* is called upon to set the apparatus, to give the prearranged stimulus, to record the time elapsing between stimulation and *O*'s movement, and to work out the numerical results of the experimental series. On the other hand, *O* is called upon to introspect the reaction consciousness, to give an introspective photograph of the processes that begin with the ready-

signal and end with the performance of the prearranged movement. This 'reaction consciousness' is the laboratory form of the 'action consciousness' of everyday life. An action, in popular parlance, is a movement made at the prompting of some conscious motive. The action consciousness consists, accordingly, of (a) a group of perceptions and ideas, the motive, and (b) a group of organic sensations, aroused by the movement of some bodily member. In the typical form of action, the former of these complexes is (c) attended-to, and the consciousness is therefore (d) an affective consciousness. In the reaction experiment, we make an artificial or schematic motive; we reduce the organic sensations to their lowest terms, by requiring the movement only of a single finger; and we secure attention, and regulate the direction of attention, by instructions given to O before the experimental series begins.

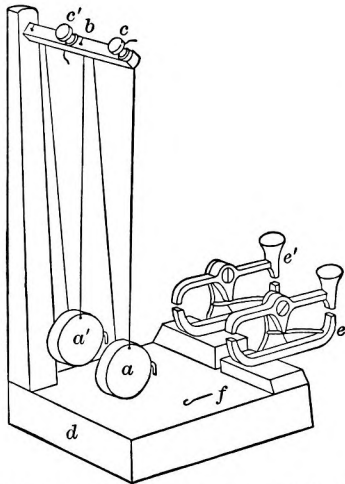

FIG. 21.—Vernier chronoscope (Clark University Lab., \$5.00).

Before we enter upon the experiment, it will be well to remind ourselves of the main points in the psychology of action.

Question (1) What is the problem that action sets to psychology?

(2) What is the typical 'motive' to human action, the motive from which all others may be derived?

(3) Make a Table, in the form of a genealogical tree, of the simpler forms of action. Give a full account of the composition of the motive in every case.

MATERIALS.—Vernier chronoscope, with accessories. [This instrument is figured in Fig. 21. As it is put in your hands, it consists of the cast-iron base and upright, *d*, with brass cross-bar, *b*; two brass pendulum bobs with face-hooks, *a* and *a'*; two lengths of stout silk, the one red and the other white; two

thumb-screws, c and c' ; two light brass-wire hooks, f ; two reaction-keys on brass posts, e and e' ; two large set-screws; a grey cardboard screen with a circular hole, 0.75 cm. in diameter; a bent piece of stout brass wire, threaded below and carrying a clip above; black, white and coloured papers; cotton wool; a short piece of rubber tubing. You will also need scissors, a screw-driver and a stop-watch.

The apparatus is set up and tested as follows. (a) Place the posts of the keys e and e' in the holes made for them in d . The key whose upper bar has a threaded hole is to be placed on the lower step of d (e in Fig. 21). Turn the set-screws into the side of the base, so that the key-posts are securely held. See that the keys face the base squarely, and not at an angle. (b) Knot the threads through the holes pierced for the purpose in b . Thread them twice (through, over, and through again) through the bobs a , a' . Bring their ends back to b , and clamp them by the screws c , c' . See that the threads lie in the four grooves cut for them on the surface of b . The bobs must hang quite evenly in the middle of their threads. (c) Place the hooks f between the lips of the keys, and hook the bobs into them by the face-hooks. Now release the nearer, longer pendulum by pressing the button of the lower key. Count the swings of the pendulum by help of the stop-watch. Note how many full, *i.e.*, back and forth swings occur in 1 min. Adjust and readjust the pendulum, by help of the thumb-screw c , until there are exactly 75 swings to the 1 min., — *i.e.*, until the length of a single swing is precisely 0.8 sec. When you have obtained this value, turn the pendulum up, out of the way, over the bar b . (d) Repeat the procedure with the farther, shorter pendulum. Take the time of swing in the same way. Adjust and readjust the pendulum, until there are 77 full swings to the 1 min. This gives (approximately) 0.78 sec. as the time of a single swing. (e) The time 0.78 sec. is the time required for a swing of the shorter pendulum. Suppose that we have it exactly: then it is clear that the longer pendulum will make 39 full swings while the shorter is making 40. Test your settings by letting the two pendulums swing together, and counting the number of swings of the long pendulum that elapse between coincidence and coin-

cidence of the four threads, *i.e.*, between the times of their lying in one and the same plane. It is not at all difficult, after a little practice, to be sure as to the moment of coincidence.

As your setting was not to 0.78 sec., but to a slightly smaller time, it may be that the coincidence does not fall precisely at the 39th, 78th, 117th swing of the longer pendulum. You must then lengthen the shorter pendulum a trifle: do not touch the longer pendulum. When the ratio 39:40 has been secured, the instrument is ready for use. We do not at present need the screen, papers, etc.]

The principle of the instrument is that of the nonius or vernier (so called from the French mathematician, P. Vernier, ? 1580-1637). In space measurements, the vernier consists essentially of a short graduated scale, *ab*, which slides along the principal scale *AB*. Its length is ordinarily equal to 9 of the *AB* units (hence the name 'nonius'), and it is itself divided into 10 equal parts. The nonius unit is thus 0.9 of the unit of the principal scale.

Let us apply the vernier to the measurement of the object *mn*. The object is longer than 4 and less long than 5 *AB* units. More than this we cannot tell from *AB*, except by ocular measurement; the scale itself does not help us. Now let us slide the vernier towards *mn*, so that the ends *n* and *a* touch; and let us see which of the scale-marks on the vernier is exactly coincident with a

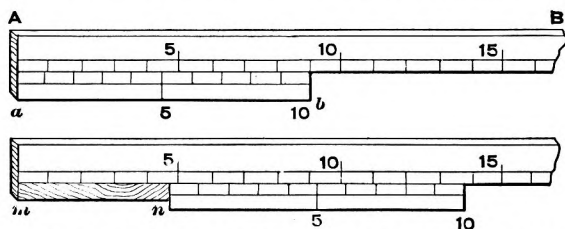

FIG. 22. — From Ganot's Physics (trans. by E. Atkinson), 1890, 5.

scale-mark upon *AB*. In the figure, it is the eighth vernier mark, counted from *n*, which is thus coincident. This means that the length of *mn* is 4.8 units of *AB*.

The proof is very simple. We remember that each of the vernier units is 0.9 of the *AB* units. Now let us work along the vernier, from right to left, starting from the point of coincidence. At the end of one vernier unit, we are 0.1 of an *AB* unit behind the next *AB* scale-mark; at the end of 2 vernier units, we are 0.2 of an *AB* unit behind; at the end of 3 vernier units, 0.3; and so on. At the point *n*, or at the end of 8 vernier units, we shall be 0.8 of an *AB* unit behindhand; or, as we said just now, the length of *mn* is 4.8 units of *AB*.

This vernier has increased the accuracy of the scale AB tenfold. Whereas we could, by that scale, read only to the AB unit, we are able by help of the vernier to read to 0.1 of the AB unit. And it is evident that by increasing the length of the vernier we may obtain an even greater degree of accuracy. If the length of the vernier be equal to 49 of the AB units, and the vernier itself be divided into 50 equal parts, we can read to 0.02, instead of only to 0.1, of the AB unit. And so on.

The vernier chronoscope applies the principle of the vernier to time, instead of to space. A full swing of the large pendulum, 0.8 sec., corresponds to the AB unit; a full swing of the shorter pendulum, 0.78 sec., corresponds to the ab unit. Suppose that we wish to measure a time: the time elapsing between the starting of the longer pendulum and the later movement of the shorter. We count, first of all, the swings that the longer pendulum makes before the shorter pendulum moves: say, 0, 1, 2, 3, 4: just as we first counted the 4 AB units in measuring mn . Now the shorter pendulum begins to swing. How long after the beginning of the last swing of the long pendulum did it start? We have only to know the number of swings that it has made when coincidence with the longer pendulum is reached, and we have our answer. There were eight scale-marks to coincidence on the space-vernier, and the extra piece of mn was therefore 0.8 of an AB unit. Let the shorter pendulum have made 8 swings when its threads coincide with those of the long pendulum. There are 40 vernier units to 39 long-pendulum units; the vernier reads, therefore, to $\frac{1}{40}$; and $\frac{1}{40}$ of 0.8 sec. is 0.02 or $\frac{1}{50}$ sec. The extra time is accordingly 8×0.02 sec.; and the total time that we wished to measure is $4 \times 0.8 + 8 \times 0.02$ sec., or 3.36 sec.

The reaction times that we shall measure will never, unless by some mistake due to lack of practice on the part of E or of O , amount to a complete AB unit, *i.e.*, to 0.8 sec. We shall not, therefore, have to concern ourselves with two different counts: the count of the long-pendulum swings before the short pendulum starts, and the count of the short-pendulum swings from its start to coincidence with the long pendulum. It is only the latter count that is necessary. Further: it is a good deal easier for E to count the swings of the long than to count the swings of the short pendulum, which is farther away from him and lies behind the other. As the number of swings is the same in either case, no error is introduced by transferring the count from the short to the long pendulum.

The scheme of the reaction experiment will now be as follows. E gives the sense-impression, and at the same instant starts the long pendulum. O makes a movement in reply to the impression, and in so doing starts the short pendulum. E counts the number of long-pendulum swings from the starting of the short pendulum to the moment of complete coincidence of the four threads; or—for we have seen that this is the same thing—counts the number of swings of the long pendulum from *its* start to the moment of complete coincidence. This number gives the reaction time in fiftieths of a second.

A. We begin with the various forms of simple reaction to auditory stimuli.

(1) *The 'Natural' or 'Central' Reaction*

PRELIMINARIES. — The chronoscope, adjusted in the manner described above, is set up at the end of a high table. It is well, though it is not necessary, to clamp the base to the table. *O* sits on a high chair sidewise to the end of the table; his right arm lies comfortably upon a cushion, and is so placed that the forefinger of the right hand can rest easily and lightly upon the button of the higher key. *E* sits on a lower chair at the side of the table, squarely fronting the pendulum bobs, so that he can accurately gauge the position of the threads.

The brass hooks are placed in the lips of the keys, and the keys closed. The face-hooks of the bobs are caught in the key-hooks. *E* lays the stop-watch on the table before him, and takes a light wooden rod in his right hand.

EXPERIMENT. — At the word "Ready!" *O* closes his eyes, and lays his finger lightly upon the button of the reacting key. *E* then says "Now!" and after an interval of 1.5 to 2.0 sec. (measured by the stop-watch) raps sharply but not heavily upon the button of the stimulus key. The sound thus made is coincident with the release of the long pendulum. On hearing the sound, *O* presses the button of the reacting key, and thus releases the short pendulum. *E* counts the swings of the long pendulum, from the time of its starting to the time of the first coincidence of the four threads. The number of swings, and the number of the experiment, are recorded.

O opens his eyes after the reaction movement, and (without looking at the chronoscope) writes out his introspection. He is to give an account of the contents of consciousness, from the "Now!" to the movement of his finger. The important points to note are (*a*) the composition of the motive, and (*b*) the degree and direction of attention. Ten experiments are to be taken in this way, and then *E* and *O* change places. When each has given 50 reactions, the first series may be considered complete. The numerical results are to be worked up as the Instructor directs, and to be entered, with the introspections, in the note-book.

(2) *The 'Complete' or 'Sensorial' Reaction*

Preliminaries are as before.

EXPERIMENT. — Before attempting this form of reaction, *O* and *E* are to receive full directions from the Instructor as to the conduct of the experiment. After the directions have been given, and, again, before the experiment begins, the following Question should be answered.

O (4) What is the composition of the motive to the sensorial reaction?

Introspection is concerned principally with this motive and with the degree of attention. The experiment is to be performed in alternate series of 10. *E* and *O* should both, if possible, give 100 reactions.

(3) *The 'Abbreviated' or 'Muscular' Reaction*

The procedure is as before. New instructions are to be received by *O* and *E*, and a similar question answered by *O*. One hundred experiments should be made.

(4) *The 'Natural' Reaction*

If time permits, *E* and *O* should give a second series of 50 natural reactions, so that each makes, in all, 300 experiments.

B. We pass now to the three forms of reaction to *cutaneous* stimuli.

(1) *The 'Natural' Reaction*

PRELIMINARIES. — *E* sits as before. *O* sits facing the end of the table, his arms resting upon it in such a position that his two forefingers may be laid upon the buttons of the keys. No pains should be spared to make this position comfortable.

EXPERIMENT. — At the word "Ready!" *O* closes his eyes, and lays his fingers lightly upon the two keys. *E* says "Now!" and after an interval of 1.5 to 2 sec. (which he should at this stage be able to estimate, without recourse to the stop-watch) raps sharply with the side of his own finger upon *O*'s left forefinger. The blow gives the required pressure stimulus and releases the long pendulum. The experiment continues as before. *E* and *O* should each make 20 experiments.

(2) *The 'Complete' Reaction*; (3) *The 'Abbreviated' Reaction*

These experiments are performed as before, *E* and *O* each taking 50 under each rubric — so that they make 120 cutaneous reactions in all.

C. Finally, we have the reactions to *visual* stimuli.

(1) *The 'Natural' Reaction*

PRELIMINARIES. — We must, in these experiments, rule out the noise made, when the stimulus key is opened, by the striking together of the outer lips. For this purpose, a bit of cotton wool is laid between the lips, and then a piece of rubber tubing, 1 cm. in length, is slipped over the bars, as if to connect them. The key still has plenty of play; but no disturbing sound is made when the button is pressed down.

The side-wire is now screwed to the top of the key, and the screen inserted in the saw-cut in the base. Note that the clip at the end of the side-wire moves about 1 cm. outward when the key is opened. A piece of black, white or coloured paper (the quality of which is known to *O*) is put in the clip, and trimmed to such a size that it is just invisible when the key is closed, but fills the circular hole in the screen when the key is open.

EXPERIMENT. — *O* sits sidewise to the end of the table. The chronoscope is set across the corner of the table, not square with it; so that *O* can see the screen clearly, while at the same time *E*, if he shifts his chair a little, has an equally clear view of the threads. At the word "Ready!" *O* lays his finger upon the reacting key, and at the word "Now!" fixates the opening in the screen.

E and *O* each make 20 experiments.

(2) *The 'Complete' Reaction*; (3) *The 'Abbreviated' Reaction*

E and *O* each make 50 experiments under both headings, thus taking 120 visual experiments in all.

RESULTS. — *E* has the 9 series of reaction times, worked up as directed by the Instructor, and the corresponding series of introspections from *O*. The following Questions arise.

E and *O* (5) What are the norms of the simple reaction time? What is the average time-difference between the sensorial and the muscular reaction? How do you account for it?

E and *O* (6) How could you adapt the vernier chronoscope to reaction experiments upon taste and smell?

E and *O* (7) Suggest further reaction experiments.

O (8) Outline the composition of the motive in your reactions, with special reference to your ideational type.

E and *O* (9) How does the simple reaction differ from the simple voluntary action of everyday life? We called it the 'laboratory form' of such action. Is it merely a simplified form?

E and *O* (10) What happens if the attention is allowed to relax in the three forms of simple reaction?

E and *O* (11) What are the characteristics of Practice as a state of consciousness? How, in other words, does the practised consciousness differ in introspection from the unpractised?

PART II

PERCEPTION, IDEA AND THE ASSOCIATION OF IDEAS

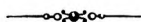

CHAPTER IX

VISUAL SPACE PERCEPTION

§ 40. **Perception.** — The psychology of perception follows directly and without break from the psychology of sensation. We may express this fact, for the sake of better understanding, in either of two different ways. We may say that the perception takes us a step nearer to the 'real' mind than sensation does; perception is one degree less abstract, has a little something upon it of the warmth and immediacy of our concrete experience: or we may say that perception is, in structure, an aggregate or group of the sensations which we have been defining, and that our study of it naturally follows, as study of the hydra, *e.g.*, follows that of the amœba.

Neither of these statements, however, is more than a half-truth. We are, in a way, getting towards the 'real' mind, when we attack perception. But we are still well within the sphere of abstraction. Mind, the mind that we use in everyday life, is not a sum or series of perceptions; and perceptions no more occur separately, in real experience, than do sensations. The popular view is to the effect that we have our perceptions of size and shape, rhythm and scale, distance and direction, duration and frequency, pigeon-holed and labelled somewhere 'in the mind,' and that we draw them out for use, separately, as the particular occasion requires. And the psychologies, no doubt, do something to confirm such a belief, by the mere fact that they

treat of perceptions one by one, in separate paragraphs. Let us, then, once and for all, throw this view overboard; and take in its place the belief—however paradoxical at first sight—that *we never have a perception*. Consciousness is a shifting tangle of processes, themselves inconstant, and the perception is a little bit of pattern ravelled out from the tangle and artificially fixed for scientific scrutiny.

The second half-truth is that a perception is an aggregate or group of sensations. To make this a whole truth, we must qualify it in two ways. (1) Not every group or aggregate of sensations is a perception. Take a simple case. The connection of sweet, sour, cold, pressure, green, we will say, gives you the lemonade-perception. But put together salt, bitter, warm, strain, blue. There is no perception: even if the tastes and the colour and temperature correspond, so far as they go, to the perception of some liquid, still strain will not fit in, and pressure (the feel of the stuff in the mouth) has been left out. You see, then, that a perception is not simply an aggregate or group of sensations; it is an aggregate or group of sensations put together under certain conditions, arranged or harmonised upon certain patterns. The conditions are found in the physical world about us, and the arranger or harmoniser is Nature herself.

Note the corollary. Lemonade is not what we supposed it to be: a connection of sour, sweet, cold, pressure, green. For the cold and pressure are *localised* in the mouth, and the bare sensation has no mark of locality upon it. Moreover, the green is a *transparent* or *translucent* green, not a green pure and simple. The lemonade-perception implies the perception of locality, of place where, and the perception of transparency; there is arrangement behind arrangement, harmony within harmony. No account of perception is complete which fails to note, besides the constituent sensations, the conditions under which these sensations have been put together.

(2) The other qualification is this. The perceptions that we tease out from our present consciousness are of very ancient origin, far older than man. Now we are told by the biologists that the few years of embryonic and child life recapitulate the life history of the human race; but that they do not just repeat

that history, with minutes in place of centuries, — they show all manner of short cuts in development, so that it is often difficult or impossible to parallel the growth of the individual with the growth of the species. Very much the same thing holds of mind. Mental process, too, has its short cuts; we do not pass through all the ancestral stages. And perception is, in this respect, the most puzzling of all mental formations. The original pattern has been modified: old sensations have dropped out, and new sensations have come in to take their places; or perhaps, to make our task still more difficult, old short-cuts have gone, and new short-cuts have been superinduced upon the fragments of the old material. You will understand this better when you have worked through the perception experiments. It accounts for the fact that there are so many, and so divergent, 'theories' of perception: why should there be different theories, if the psychology of perception meant merely the dissection of sensation groups? And it accounts, too, for the instantaneousness and sense-directness of perception: how could we *see* how far off a thing is, the first time that we look at it, — how could we *hear* a melody, the first time that it is played to us, — if we had to travel all the slow and tedious journey that our ancestors travelled in the time when the perceptions of tune and distance were in the making?

A perception, therefore, is primarily a group of sensations, arranged by external nature; but it has seen so much wear and tear, and has been so often amended and remodelled, that to know it we must know its history and genesis. The psychologist has a threefold problem before him: the analysis of the constituent sensations; the tracing of the pattern, the mode of connection, imposed upon them; and the discovery of the substitutions and short-cuts that have obscured the original formation.

Do not, however, let the complexity of this problem cause you to lose sight of what was said at the outset: that the psychology of perception follows without break from that of sensation. We may wish (for it would make things easier) that mind were a mechanical puzzle, so that the analysis of the constituent sensa-

tions should be the sole problem of perception. But the fact that mind is not a mere mosaic of sensation-bits, that there are the mode of connection to trace and the substitutions and short-cuts to discover, does not mean that anything psychological has intervened between the sensation and the perception. It is sensations that fit together in a pattern, sensations that are substituted for one another, sensations that form the cross-country tracks when the highway has proved to be too roundabout. The results of our genetic study, cross-sections of the perception tissue at various stages of its development, never transcend sensation. Or, to put the same thing in another way: we appeal to history, not because there is in the perception something more than sensation, some foreign contents which genetic study will discover for us, but simply because the series of cross-sections explains certain peculiarities of mental structure whose 'material causes' are not to be found in the adult human consciousness. Always and everywhere, we must explain perception in the light of sensation.

§ 41. **Visual Space Perception: Preliminary Exercises.** — "In order to understand the theory and construction of the stereoscope," writes Sir David Brewster, "we must be acquainted with the theory and general structure of the eye, with the mode in which the images of visible objects are formed within it, and with the laws of vision by means of which we see those objects in the position which they occupy, that is, in the direction and at the distance at which they exist." We are to discuss the stereoscope presently: but, in any case, we cannot approach the problems of visual space perception without the knowledge of which Brewster speaks. We must, in particular, have a thorough understanding of (1) the structure and function of the 'reduced' eye; (2) the formation of the retinal image; (3) the mechanism of accommodation; (4) the laws of binocular eye movement; and (5) the doctrine of corresponding points and double images. We will take up these topics in order.

(1) *The Reduced Eye.* — We may regard the eye as composed of two distinct structures: the retina or sensitive film, and the rest of the eyeball, consisting of the dioptric mechanism. The dioptric apparatus is, in reality, very complicated. We have

four refracting surfaces: the anterior and posterior surfaces of the cornea, and the anterior and posterior surfaces of the lens; and four refracting media: the substance of the cornea, the aqueous humour, the substance of the lens, and the vitreous humour. Even so we have made matters too simple: for the substance of cornea and lens is not uniform, and the capsule that covers the anterior surface of the lens is different in structure from the lens itself.

Fortunately, we are not compelled to work with so complex a system. If we know (*a*) the refractive index of each medium, (*b*) the radius of curvature of each surface and (*c*) the distance between surface and surface along the optical axis of the system, we are able mathematically to effect a reduction or simplification of the apparatus. This simplification, in the case of the eye, leaves us with a single refracting substance and a single (ideal) spherical surface. The substance has the refractive index of water, 1.33; and the surface a radius of 5 mm. The distances along the optical axis of this ideal system are: limiting surface to nodal point, 5 mm.; nodal point to posterior principal focus, about 15 mm. The whole dioptric mechanism is thus reduced to a convex lens, with a collecting power of about 50 diopters, or a focal distance of 2 cm.

The simplified eye is termed the 'reduced eye of Listing,' after the Göttingen physiologist by whom it was first worked out.

QUESTIONS. — (1) Draw to scale, $\times 5$, diagrams of the real and the reduced eye (left eyeball, horizontal section). Number the surfaces and media of the former diagram, and make out a Table of all the measurements necessary to reduction. Mark the four cardinal points of the reduced eye, and make out a Table of the corresponding measurements.

(2) Define: principal point, nodal point, principal focus, optic axis, diopter.

(2) *The Formation of the Retinal Image.* — The retinal image is a real, smaller and inverted image of the external object. Its position and magnitude are determined by lines drawn from all points of the object through the nodal point of the eye to meet the retinal surface. These lines are termed lines or rays of direction. The terminal point of a ray of direction upon the

retina is thus the image-point of the object-point from which the ray proceeds.

Retinal images are not equally clear and distinct at all parts of the retinal surface. Points imaged upon the fovea centralis, the central depression of the macula lutea or yellow spot, are seen clearly (direct vision); points imaged upon the outlying portions of the retina are seen less clearly (indirect vision). When we 'look at' a thing, we turn the eye and head in such a way as to bring its image upon the fovea. The difference between the foveal and the lateral images has been compared to that between images that are in and out of focus (Wundt), or to that between a carefully finished drawing and a rough sketch (Helmholtz).

QUESTIONS. — (3) Draw a diagram of the formation of a retinal image in the reduced eye.

(4) Define: fixation point (point of regard), line of vision (line of sight), line of regard, field of vision, field of regard, sighting line, visual angle.

(5) Draw a diagram, showing the relations of the optic axis, the line of vision, the line of regard, and the principal sighting line. Make the diagram at least as large as the figures of Question (1).

(6) Assure yourself, by direct inspection of a retinal image (method to be indicated by Instructor), that its characteristics are as given in the text.

(7) Can you see any advantage to the organism in the differentiation of the retina for direct and indirect vision?

(3) *The Mechanism of Accommodation.* — We know that the lens of our ordinary optical instruments (photographic cameras, opera glasses) gives a clear and perfect image of the object upon which it is focussed. If, however, we wish to obtain a clear image of some object that lies beyond or within this focal distance, we have to readjust the instrument. We must either alter the distance between the lens and the screen upon which the image of the object is thrown (this we do in the camera, in the telescope, in opera glasses); or, the screen remaining constant, we must replace the original lens by another, different one (this is usually done in the microscope).

In the eye, the distance between the lens and its screen, the retina, is constant. The mechanism of accommodation must, therefore, rather resemble that of the microscope than that of the photographic camera, only that, of course, there is no actual interchange of lenses. The lens of the eye is an elastic body, held between two layers of membrane (the suspensory ligament), whose tension can be lessened by the action of the ciliary muscle. In distant vision (far accommodation, relaxed accommodation), the muscle is inactive, the suspensory ligament is taut, and the lens is accordingly compressed. In near vision (near accommodation, or 'accommodation' simply), the muscle pulls upon the choroid, the ligament becomes less taut, and the anterior surface of the lens bulges forward in virtue of its elasticity. In other words, the lens in far accommodation is a less convex, and in near accommodation a more convex lens. The single elastic substance takes the place of the series of different objectives in the microscope.

The near limit of accommodation, for the normal or emmetropic eye, is about 12 cm.; the far limit is infinity. Infinity begins, however, at a distance of some 65 m.: since rays which reach the eye from a point at that distance may, for all practical purposes, be considered as parallel.

QUESTIONS. — (8) Draw a diagram, illustrating the mechanism of accommodation for far and near points.

(9) Assure yourself, by observation of Sanson's images (method to be indicated by Instructor), that the essential thing in accommodation is the bulging forward of the anterior surface of the lens.

(10) Perform Scheiner's experiment (method to be indicated by Instructor). What light does it throw upon the problem of accommodation?

(11) Name some of the commonest and most disturbing imperfections of cheap optical instruments. Can you devise tests which shall decide whether the eye suffers from them?

(4) *The Laws of Binocular Eye Movement.* — So far we have been working with a single eye, and with that eye at rest. Such a treatment is, of course, artificial. As Wundt says: "the eye is, from the first, a moved organ, and always functions, in normal

vision, as a double eye." We pass, therefore, to the consideration of this moving double eye. And we shall deal, first, with movement.

It is a remarkable fact that there is no trace, in the space perceptions of everyday life, either of the separateness of the muscular systems of the two eyeballs, or of the separateness of the two retinas. We know that we have two eyes, but we know it only 'by accident.' We may become aware of it by touch; by the reflection of our face in the mirror; by analogy from the faces of our friends; by 'getting something into' one of the eyes, and so finding it temporarily useless. Nevertheless, the two eyes work so well together, that ordinary visual perception gives no clue to their distinctness; to all intents and purposes we might be seeing with a single Cyclopean eye set in the middle of our foreheads.

This singleness of visual space perception must mean, on the one side, that the eyes *move* together by a single impulse. And we find, as a matter of fact, that the movements of the eyes are automatically coördinated for purposes of single vision. It is clear that, if the eyes are to function together as one organ, they must fixate in common; the lines of regard must be restricted to movements where a common fixation point is possible. There must, *e.g.*, be no divergent movements of the eyes, and there must be no asymmetry of up and down movements, — no moving-up of the one eye and lagging behind of the other. Under such conditions there could be no common fixation point. Consequently no such movements occur.

The movements that do occur give evidence of three distinct automatic coördinations of the muscles of the two eyes. The eyes move *up and down* together; there is coördination of the superior and inferior recti and of the corresponding (inferior and superior) obliqui in the two eyes. The eyes move together to *right and left*; there is coördination of the external rectus of the one eye with the internal rectus of the other. And the eyes turn *in* together; there is coördination of the two internal recti. These coördinations are fixed by the physiological mechanism; if they are not connate, they take shape automatically as the infant begins to use his eyes. They permit of three types of

movement. We find (*a*) movements in which the fixation point is infinitely distant, and the lines of regard parallel. These are movements up and down, or to right and left. We find (*b*) movements of symmetrical convergence, in which the lines of regard converge upon a common fixation point lying somewhere, nearer or farther, up or down, in the median plane of the body. And we find (*c*) movements of asymmetrical convergence, compounded (not consciously, but so far as physiological innervation goes) of a lateral parallel movement and a movement of symmetrical convergence. The result of each and all of these movements is that some luminous point in objective space, lying within the range

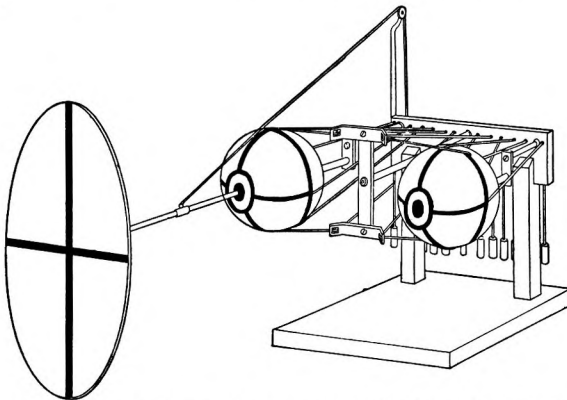

FIG. 23.—Ophthalmotrope (Zimmermann, Mk. 64). See Helmholtz, *Phys. Optik*, 1896, 667.

of accommodation, is imaged upon the foveas of the two retinas, *i.e.*, that a common fixation point is secured.

QUESTIONS. —(12) Work out, by aid of the ophthalmotrope, the actions of the six eye-muscles. Draw a diagram, illustrating the directions of action and the axes of rotation of the muscles.

(13) Define: centre of rotation, primary position, secondary position, median plane, torsion (wheel movement, swivel rotation), false torsion, orientation.

(14) "Of the first importance among eye movements," says Sanford, "is a certain constant reflex tendency." What is this tendency?

(15) Show by a diagram how the innervation for a movement of asymmetrical convergence is compounded of the two innervations mentioned in the text.

(16) Verify by experiment (method to be indicated by Instructor) the laws of Donders and Listing.

(5) *Corresponding Points and Double Images.*—If the singleness of visual space perception means, on the one hand, that the eyes move together, it must also mean, on the other, that the two retinas see together. We have already noted that the two foveas ‘correspond’ in this way; the object-point fixated in common by the two eyes is seen single. There must be a further, similar correspondence between image-points outside of the foveas.

The simplest way to think of this correspondence is to regard the two retinas as exact duplicates, and the two retinal images as simply superposed. Imagine two hollow hemispheres of thin metal, divided into quadrants by a vertical (black) and a horizontal (white) meridian. Lay the one in the other, with the meridians coincident, and drive a pin through any point of the two surfaces. The pin-holes will represent corresponding retinal points. Holes in the upper and lower halves of the one hemisphere will correspond to holes in the upper and lower halves in the other; holes in the nasal and temporal halves of the one will correspond to holes in the temporal and nasal halves of the other. Any point of light, then, which is imaged at two corresponding pin-holes will be seen singly by the two eyes. Any point of light imaged at non-corresponding pinholes will be seen double.

This view is, in the main, correct; but the exact geometrical representation must be somewhat modified. In the first place, the apparent vertical meridians of the two retinas do not exactly coincide. If we are to draw them as they are given in perception, putting the ‘subjective’ for the ‘objective’ vertical, our two black lines must not overlap, but diverge upwards by about 2° . In the second place, the corresponding points are not geometrically identical: a ‘point’ on the one retina corresponds to a small area on the other, a pin-hole in the one hemisphere to a nail-hole in the other. We must therefore, change our former statement, and say: any luminous point imaged on non-corre-

sponding *spots* of the two retinas will be seen double. The perception of double images as such, however, plays so small a part in real life that their existence "remains unknown to many people, even in adult life" (Helmholtz).

QUESTIONS. — (17) Define: identical points, congruent points, disparate points, lines of separation, retinal horizon.

(18) Verify by experiment (method to be indicated by Instructor) the divergence upward of the vertical retinal meridians.

(19) Devise a simple method for the demonstration of double images. Draw diagrams, illustrating the formation of double images with fixation before and beyond the object. Note the apparent positions of the double images with reference to the fixation point. How do these binocular double images resemble those of Scheiner's Experiment?

(20) "We have learned by experience to neglect double images, and to see things as they really are." Criticise this statement.

EXPERIMENT XXVII

§ 42. **Visual Space Perception: Stereoscopy.**—Our two eyes are, so to speak, two little photographic cameras, which take two pictures of every object that we see. These two pictures are slightly different, since the same object is photographed from two slightly different positions. Now when we turn the two eyes upon an object, we do not as a matter of fact see the object double, but we see a single object *solid*. Vision of this sort, vision of a solid object or of an object in tridimensional space, is termed 'stereoscopic' vision (Gk. *στερεός*, solid, and *σκοπεῖν*, to view).

It is evident that the conditions of stereoscopic vision can be synthetised, artificially reproduced, without our having recourse to more than two dimensions of space. For the two slightly different pictures taken by the two retinas are plane pictures, not themselves solid fac-similes of the object. Suppose, then, that we make two drawings on paper of one and the same thing, — one drawing of the thing as it looks to the right eye, and another drawing of it as it looks to the left, — and that we present each drawing to its appropriate eye. The two drawings, reversals of the two retinal images of a single object seen in

perspective, must combine to form the representation of such an object, *i.e.*, must give us the illusion (or rather the synthesis) of the third dimension. Let us test this argument.

MATERIALS. — Truncated cone, of wood or card. [The exact dimensions are immaterial. A cone of 10 cm. diameter at the base and 2.5 cm. at the frustum, 8 cm. high, does very well.] Stiff wire or thread. Pencil and paper. White cardboard. Scissors.

EXPERIMENT (1). — Support or suspend the cone, at the height of the eyes and at a distance of about 1 m. from the face, its axis lying in the median plane of the body. Close the right eye, and make an outline sketch of the cone (omitting light and shade) as it appears to the left. With the head in the same position, close the left eye, and make a similar drawing of the cone as it appears to the right.

Cut a strip of white cardboard, 17.5 by 8.5 cm. On this draw accurately in ink the two figures that you have just sketched. Make the diameter of the outer circles 3 cm., and the distance from centre to centre of the two figures 6.5 cm. Be sure that you enter the right-eye figure on the right, and the left-eye figure on the left.

Hold up the card before the eyes, at about 25 cm. from the face. Look straight forward, as if you were looking through the card, at some point lying midway between the two drawings at the other end of the room. The two figures will approach each other, and at last will overlap, fitting together with a 'snap.' At the moment of complete overlapping, the cone stands out with an almost startling tridimensionality. "It is," says Ruete, "as if the two images, when they have come very near to each other, attract one another with an increased velocity."

Again, we may have the fixation point before the card, instead of behind it. Cut another piece of cardboard, and draw on it the same figures in reverse order. Hold the card as before, in your left hand. Bring up the point of a pencil, in the median plane, to about 9 cm. from the face. Fixate the pencil point. The two figures approach, and finally fuse. This experiment is, perhaps, somewhat easier on the average than the preceding, and the result is even prettier, the outline of the stereoscopic figure being naturally much more distinct.

In both forms of the experiment the card may be moved in or out, if need arise.

The following Questions, to be answered both by *E* and by *O*, suggest themselves.

(1) When the fusion has taken place, each of the original figures is still seen separately, to right and left of the single solid figure. Why is this? Why should they not disappear in the solid figure?

(2) If the fixation point is beyond the card, the solid figure looks larger than the plane figure on either side of it; if the fixation point is on this side of the card, the solid figure looks smaller. Why is this?

(3) Draw diagrams, showing the optical principles upon which the two experiments are based: showing, in particular, why the order of the figures upon the card must be reversed in the second experiment.

(4) Suggest simple devices (apart from mirrors, lenses and prisms) whereby the obtaining of the stereoscopic effect may be made easier.

We pass now to a more systematic enquiry into the range and conditions of the phenomenon of stereoscopic relief.

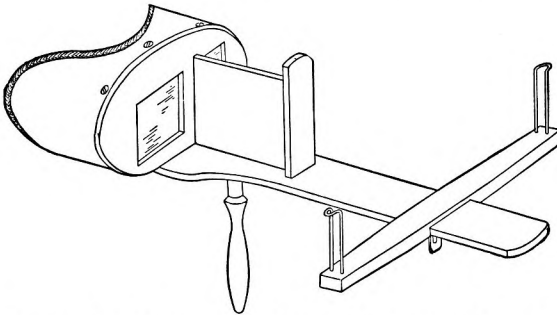

FIG. 24. — Hand stereoscope (Petzold, Mk. 8.50; Chicago Lab. Supply Co., \$1.50).

MATERIALS. — Hand stereoscope. [This consists, in general, of a light wooden hood, fitting closely over forehead and nose, and edged with plush or velvet; two semi-double convex lenses, the refracting instruments; a short screen, ending in a broader

upright, in the median plane; a wooden bar, along which the slide-carrier travels; and the slide-carrier itself,—a small wooden platform, grooved for the reception of the slide, and furnished with a light wooden back and a wire spring to hold the card in position.]

Set of stereoscopic slides.

Question (5) Draw a diagram, showing the optical principles upon which the refracting stereoscope is based. The semi-double convex lenses are to be regarded as lenticular small-angle prisms. What do the prisms do? What is gained by making them lenticular? What is the use of the hood of the instrument? What is the function of the bar along which the slide-carrier runs? Of the central screen and pillar?

EXPERIMENT (2). — We require here, as special Materials, two long, black-headed shawl pins, and a sheet of white cardboard.

Set up the pins, at a convenient distance, in front of the white background, in such a way that one of them stands in the median plane of the body, and the other to the left of this and farther off. Observe them with the right and left eye alternately, the head remaining in the same position. Note that to the right eye the heads appear nearer together than they do to the left. Draw a diagram, showing why this should be the case. — Place Slide i. in the stereoscope. What do you see? Invert the slide. What do you see now? Why?

EXPERIMENT (3). — We may use straight lines or curves instead of the dots. Place Slides ii. and iii. in the stereoscope. What do you see? Why? Invert the slides.

EXPERIMENT (4). — We require here, as special Materials, a flat ruler.

Hold the ruler, edge upwards, in front of your face, the lower end coming in towards you and the upper end tilted out from you in the median plane. Look beyond the ruler at some distant fixation point, so that its binocular image falls into double images. Close the left eye, and draw the ruler as it looks to the right; close the right, and draw the ruler as it looks to the left.

Change the position of the ruler, so that its upper end slants in and its lower end out, in the median plane. Make drawings as before.

Place Slide iv. in the stereoscope. Invert it. Describe and explain what you see.

EXPERIMENT (5). — Slides ii. and iv. give the two fundamental experiments of stereoscopic vision. Place Slides v. to xvii. in the stereoscope, and describe what you see, explaining the phenomena in the light of the foregoing experiments.

EXPERIMENT (6). — So far, we have combined diagrams, each of which is capable of a definite interpretation in terms of perspective. Even the two dots on either side of Slide i. may represent two points at different distances from us, however much we may incline (seeing each half of the slide singly) to think of the dots as lying in the same plane; and, if we give them a perspective interpretation, the dots must represent such points. So with the oblique lines of Slide iv.; they may be slanting lines in the same plane, but, if they are perspectively explained, they must be representations of lines stretching away from us in space. We turn now to slides in which the indication of perspective is confined to one of the diagrams only; or, rather, to slides, one diagram of which is capable (if it be taken perspectively at all) of a host of different interpretations, while the interpretation actually put upon it in stereoscopic vision is determined by the character of the other diagram.

Place Slides xviii. to xx. in the stereoscope. Describe and explain what you see.

Our initial argument has proved to be valid. We have obtained the stereoscopic effect, from the simplest and the most complex figures, by presenting to each eye its appropriate picture of some tridimensional object or group of objects. It will be interesting, and it will also be important for our theory of binocular vision, to pursue the experiment somewhat farther, and to ask what happens when we combine in the stereoscope diagrams that do not fulfil the conditions of stereoscopic vision. We cannot expect to get the depth perception. What shall we get?

EXPERIMENT (7). — Slide xxi. reproduces Slide ii., with horizontal lines in place of vertical. What do you see, when it is put in the stereoscope? What is the essential difference, then, between it and Slide ii.? In which of the two (do you think)

may the discrepancy between the diagrams be the greater, if fusion is still to result?

How do you see the figures of Slide xxii.? Examine the result of combination very carefully. Is there any possible condition under which these slides might represent the retinal images of a single object, apart from tridimensionality?

Place Slides xxiii. and xxiv. in the stereoscope. Are they to be classed with the two preceding? What is the general lesson to be learned from the four slides?

EXPERIMENT (8). — This lesson encourages us to go a step farther still, and present to the two eyes two entirely dissimilar pictures. Place Slide xxv. in the stereoscope. Here you have a black figure on a white ground for the one eye, and an uniform white ground for the other. What do you see? What is there in the result that requires explanation? What explanation can you offer?

Place Slides xxvi. to xxxi. in the stereoscope, and describe carefully what you see. Can you suggest a variant of Slide xxvi. on the lines of Slide xxv., that promises interesting results? Pay especial attention to Slides xxvii. and xxviii., and do not be content to discover only one new phenomenon in them.

EXPERIMENT (9). — Place in the stereoscope Slides xxxii. to xxxvii. State, before you look into the instrument, what you expect to see. Note whether the expectation is verified. Give an explanation of the various phenomena observed.

EXPERIMENT (10). — We have hitherto used black and white (or the photographic monotone) for our slides, and have avoided colours. The following set of slides, nos. xxxviii. to xli., shows in part phenomena with which we are already familiar, and in part phenomena which we have not yet met with, or, at least, have met with only in obscurer form.

Slide xxxviii. and its variants. — Cut small squares (3 cm.) of all the coloured papers used in the experiments upon Visual Sensation. Cut a piece of cardboard, 17.5 by 8.5 cm., to serve as back for the slides. Cut a piece of neutral grey cardboard, of the same size, and make in it two square (2 cm.) windows; the windows have the same positions as, *e.g.*, the two cones of Slide

vii. Be careful that the edges of the square openings are evenly cut, and are grey (not white).

Put any two pieces of paper upon the background, behind the two windows of the grey card, and slip rubber rings over the cards to hold the slide together. Then observe the combined image of the paper squares in the stereoscope. Work through all the possible pairs of colours in this way. Note the effect of (1) colour-tone, (2) saturation and (3) brightness of the combined colours.

Slide xxxix. — Paste smoothly, upon a smooth-faced card, two small squares (1 cm.) of red and two of blue paper. Choose dark and little saturated papers. The squares must lie upon the same horizontal line, at equal distances from one another, the two reds upon the one side of the slide and the two blues upon the other.

Remove the middle screen from the stereoscope, by unscrewing the handle. Place the slide in the instrument. After combination, you see five squares. How do these five images arise? Which of them are important for the present experiment? Give an exact description of the central image.

Repeat the experiment with other papers having the same characteristics (even grain, low saturation, little and approximately equal brightness).

Slide xl. — Paste a blue paper over the one half of a slide, and cover the other half with equal vertical strips of red and green. Choose papers whose brightnesses are as nearly equal as possible.

Replace the central screen in the stereoscope, and combine the two monocular colour-fields.

Slide xli. — Cover a card with red paper. On the one half, paste a 2.5 cm. blue square; on the other, a 1.5 cm. yellow square. What do you see in the stereoscope? Why?

QUESTIONS. — (6) Define the terms and phrases that you have used in classifying or explaining Slides xxv. to xli.

(7) Devise a Slide xlii. that shall demonstrate the right of black to be regarded as a sensation quality, on a par with white or the colour qualities.

(8) Devise a Slide xliii. which shall illustrate and confirm your answer to Question (2) above.

RELATED QUESTIONS. — The following Questions grow out of the results of the present experiment, and pave the way for the next.

(9) What are the limits, and what is the explanation, of monocular stereoscopy?

(10) What are the main sources of a perfect illusion in the cyclorama?

(11) What are the secondary criteria of distance?

(12) You have seen visitors to a picture-gallery observing a picture monocularly, through a tube made of the joined hands. What is gained by this?

EXPERIMENT XXVIII

§ 43. **Visual Space Perception: Pseudoscopy.** — We found, in our experiment with the stereographic drawings of a truncated cone, that the same appearance of relief can be obtained whether we fixate a point farther or nearer than the plane of the card; but that, in the latter case, the order of the drawings must be reversed. We are now to examine the phenomena of stereoscopic ‘conversion,’ *i.e.*, the appearance of the binocular image when — to retain for the moment the language of our previous experiment — the point of fixation shifts from far to near, but the diagrams are not reversed; or when the point of fixation remains in its original position, but the diagrams are reversed.

“A very singular effect is produced,” wrote Sir Charles Wheatstone in 1838, “when the drawing originally intended to be seen by the right eye is placed at the left-hand side of the stereoscope, and that designed to be seen by the left eye is placed on its right-hand side. A figure in three dimensions, as bold in relief as before, is perceived, but it has a different form from that which is seen when the drawings are in their proper places. There is a certain relation between the proper figure and this, which I shall call its *converse* figure. Those points which are nearest the observer in the proper figure are the most remote from him in the converse figure, and *vice versa*, so that the figure is, as it were, inverted; but it is not an exact inversion, for the near parts of the converse figure appear smaller, and the remote parts larger than the same parts before the inversion.”

Conversion may be secured in three ways: (1) by transposing the pictures from the one eye to the other; (2) by reflecting the pictures, while they remain presented to the same eye; and (3) by inverting the pictures without transposing them. These possibilities are indicated in the accompanying diagram, which Wheatstone explains (1852) as follows.

“If two different objects, or parts of an object, *a*, have a greater lateral distance between them on the right-hand picture than that which they have on the left-hand picture, the optic axes must converge more to make the left-hand than to make the right-hand objects coincide, and the left-hand object will appear the nearest. If the pictures be now transposed from one eye to the other, *a'*, the greatest distance will be between the corresponding points of the picture presented to the left eye; the optic axes must therefore converge less to make the left-hand objects coincide, and the right-hand object will appear the nearest.

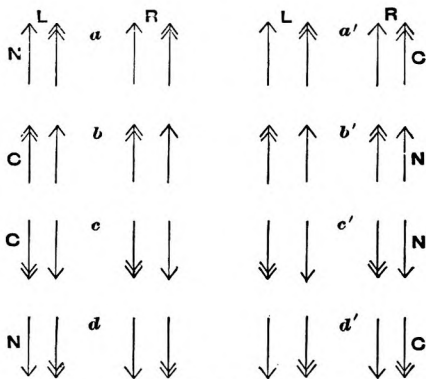

FIG. 25.—*L, R*, left, right; *C, N*, converted, normal.

“If the pictures, remaining untransposed, be each separately reflected, *b*, the relative

distances of the corresponding objects remain the same to each eye, and the left-hand object will still appear nearest; but in consequence of the lateral inversion of the objects in each picture by reflexion, that which was previously on the left will now be on the right, and therefore the object which before appeared nearest will now appear farthest.

“When the pictures are turned upside down, still remaining untransposed, *c*, the objects are reversed with respect to the right and left in the same manner as they are when reflected, and the lateral distances between the objects remaining the same to each eye, precisely the same conversion of relief is produced as in the preceding case, except that the resultant image is inverted. The diagram represents all the possible changes of the two binocular pictures; those marked *N* show the normal relief, and those marked *C* the converse relief.”

The equivalence of the three forms of conversion is well illustrated by slides of the type of Slide vi. If we cut the slide in halves, and (1) interchange the two diagrams, we are doing pre-

cisely the same thing as if we (2) presented to each eye the reflexion of its original picture, or (3) presented to each eye the inversion of its original picture. Transposition, reflexion and inversion give the same figures; and the same hollow pyramid is accordingly seen in all three cases.

Special instruments have been devised for the investigation of converted relief. Wheatstone coined for them the name 'pseudoscope' (Gk. *ψευδής*, false, and *σκοπεῖν*, to view).

MATERIALS. — Total-reflexion pseudoscope. [This consists of two brass tubes, 8.5 cm. long and 2.5 cm. in inside diameter.

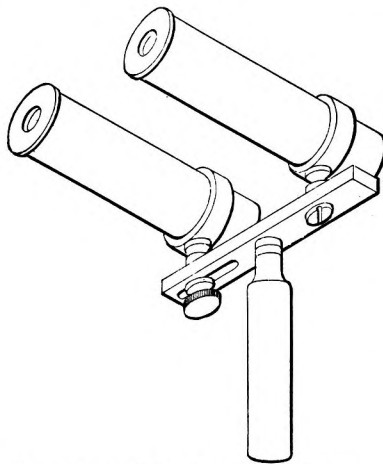

FIG. 26. — Total-reflexion pseudoscope.
Michigan App. Co., \$12.00.

At the one end of each tube is an ocular, with a circular opening of 1 cm. diameter; near the other end is a total reflexion prism. The reflecting sides of the prisms are vertical; their bases face each other, and lie parallel with the axes of the tubes. The tubes are held upon a cross-bar of metal, supported by a wooden handle. Both of them can be turned about a vertical axis, passing through the centre of the prisms; and the left-eye tube can be moved along the cross-bar to or from the other.]

Question (1) Draw a diagram, showing the optical principles upon which the instrument is based. What is the function of the tubes? Why must the prisms turn about the vertical axis? Why is the left-eye prism made to slide along the cross-bar? Which form of conversion does this pseudoscope effect?

PRELIMINARIES. — The pseudoscope may be used either for the combination of plane stereographic figures, or for the conversion of an object in external space. Since the pseudoscopic field is small, and the adjustment of the prisms may give the

beginner some little trouble, it is well to practise with the stereograms.

Set up one of the Slides v. to xiv. upon the table, at the height of the eyes, and at a distance of some 1 m. from the face. Loosen the screws of the pseudoscope, and adjust the instrument in such a way that a clear image of each diagram is shown in the opposite monocular field. Now bring the two images together, until they completely overlap in a single bright field. Note the conversion of relief.

Tighten the screws, to hold the tubes in the required position, and work through the other slides of the series.

EXPERIMENT (1).—We require here, as special Materials, a dead-finish black screen, 1 m. square, a small fixation-cross of white card, some differently coloured balls, and some differently coloured rods. [The balls may be the wooden balls, 2.5 cm. in diameter, which with a piece of elastic attached are sold as play-things at 1¢ each; pencils will serve for the rods.]

O sits directly opposite the evenly illuminated screen, at a distance of some 3 m. The white cross is pinned to the screen, and the pseudoscope is so adjusted that the cross appears at the proper distance and of its natural size. The cross is then removed, and the screws of the pseudoscope tightened.

At the word of command, *O* puts the pseudoscope to his eyes, and fixates the centre of the screen. *E*, reaching over from behind the screen, lowers two balls by their threads into the pseudoscopic field. *O* describes the relative positions of the balls, saying which colour is behind the other, and which to the right or left of the other.

In the same way, *E* brings two pencils from below or from the side into the pseudoscopic field, and *O* describes their relative positions.

Three or more balls are now suspended by threads of different lengths from a rod, which *E* holds obliquely over the screen from behind. In the same way, three or more pencils are brought into the field from below or from the side. *O* reports as before.

Question (2) Why do we set the pseudoscope for the white cross on the screen? Why should not the adjustment be

left for *O* to make as the various objects are brought into the field?

EXPERIMENT (2). — We need here, as special Materials, a number of half-hoops of wood, about 25 cm. in diameter; stiff wire.

O sits as before. *E* lowers into the pseudoscopic field, by means of a wire, one of the wooden hoops, its convexity towards *O*. *O* reports the direction of curvature. *E* then turns the concavity of the hoop towards *O*. Finally, *E* puts two or more of the hoops together, to form a convex or concave hemisphere, and shows the complex stimulus to *O*, who reports as before.

EXPERIMENT (3). — Special Materials: a square of white cardboard, 25 by 25 cm.; white paper; scissors; paste; stiff wire.

Make a paper cone, 10 cm. high and 18 cm. in diameter at the base. Paste the base of the cone by paper strips to the cardboard. Carefully cut out the circle of cardboard described by the base of the cone.

O sits as before. *E* lowers the cone by a wire into the pseudoscopic field, its vertex towards *O*. *O* describes its appearance. *E* then turns the cone through 180°, so that *O* looks into the hollow of the paper. *O* again describes the appearance of the stimulus.

EXPERIMENT (4). — On a table in front of the screen — or, better, upon a series of black shelves, arranged step-fashion before it — place a number of simple objects: balls, cones pointing to and from *O*, empty match-boxes set on end, a tea-cup (concavity towards *O*) with painted figures on the inside, a tea-cup (convexity towards *O*) with painted figures on the outside, some geometrical wire-models, a plaster medallion about 10 cm. in diameter, an intaglio cast of such a medallion, a small plaster bust, etc., etc. *O* reports the respective positions and appearances of the objects as viewed with the pseudoscope.

Up to this last experiment, everything should have gone smoothly; the pseudoscopic conversion, *i.e.*, should have been readily and certainly perceived. Now, however, the conditions are becoming more complicated. The positions of all the objects are, it is true, disturbed; but their far-near conversion presents

various degrees of difficulty and even of completeness. The same thing holds if *O* turns the pseudoscope upon objects in the room or in the landscape: sometimes there will be a complete conversion, sometimes a partial conversion, and sometimes none at all. Evidently, then, there are extraneous factors at work, which make against the conditioning of perception by the simple conversion of retinal images. Among these factors are the 'secondary criteria of distance' called for by Question (11), p. 144 above. Some of them are isolated in the following experiments.

EXPERIMENT (5). — Materials as in exp. (1). Suspend two balls by threads before the screen, as before. Set the ball that is more remote from *O* swinging, right and left, across the pseudoscopic field, — so that it passes behind the nearer ball, and is wholly or partially concealed by it, at a certain point of the swing. Let *O* report what he perceives.

Bring up two pencils into the pseudoscopic field from below. *O* notes their relative position. Lay a third pencil between the two, upon the black table or shelf, so that the lower end of the more remote pencil is concealed from *O*'s view. Let *O*, again, report what he perceives.

EXPERIMENT (6). — Materials: four squares of white cardboard, two of 4 cm., and one each of 2.5 and 5.5 cm., figured as in the diagram. The squares are to stand up on edge, so that a flap of cardboard must be left, for turning under, on one of the sides.

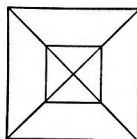

FIG. 27.

Arrange the squares, before the screen, in the positions indicated in the diagram: the line *mn* lies in the median plane of the body, and its length (the distance between the two pairs of squares) may be taken at about 25 cm. The two front squares may be some 20 cm. apart. Note that the two 4 cm. squares are in front, and the larger and smaller squares behind.

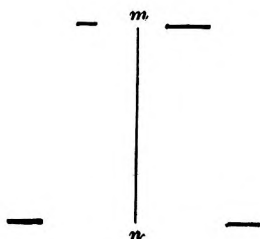

FIG. 28.

O sits at the usual distance, and looks through the pseudoscope into the 'gal-

lery' of squares. What is the resultant perception? How is it to be explained?

EXPERIMENT (7). — Materials: three pieces of heavy white-coated wire, 20 cm. long; one piece of similar, but dark-grey-coated wire, 20 cm. long; an empty spool or round ruler; four small squares of wood; a strip of black cardboard, 25 cm. long.

Bend one end of each wire round the spool, to form a closed ring. Set up the wires in the wooden bases. Place them as in Fig. 28, two white wires in front, and the grey and the remaining white wires behind. Stand the strip of black cardboard before the gallery of wires, so that *O* can see only the four rings.

O, sitting as before, looks through the pseudoscope at the four rings. What is the perception, and how is it to be explained?

EXPERIMENT (8). — Materials: piece of white cardboard, 30 by 20 cm., with flap on the longer side. Two paper cones, 4 cm. in height and 10 cm. in diameter at the base. Scissors; paper; paste; compasses; soft pencil.

Describe on the card two symmetrically placed circles of 10 cm. diameter. Carefully cut out one of the two. Paste one of the cones, vertex towards you, over the drawn circle; and paste the other, on the other side of the card, over the cut-out circle. Stand the card up, on its in-turned flap, and let a stream of light (from a sunny window, or from an electric light) fall upon its surface at an angle of some 40° . Note the shaded parabolas on the one cone and in the other. Darken these shaded areas evenly with a soft pencil.

Now turn the hollow cone inside out, so that its vertex comes towards you, on a level with that of the other. Be very careful that there is no change of place during this operation; the shaded parts of the two cones must retain their relative positions.

Set up the card before the screen, and let *O* examine the two projecting cones with the pseudoscope. Explain the perception.

EXPERIMENT (9). — Materials: pasteboard mask of the human face; oil paints.

Paint the inside of the mask as nearly as possible in fac-simile of the outside. Set the mask up, before the screen, the hollow side towards *O*. What happens when it is viewed through the pseudoscope? Turn the mask, right side towards *O*: what is the pseudoscopic perception?

The following Questions arise.

(3) Could the prisms of our instrument be replaced by plane mirrors?

(4) If reflexion implies conversion, why do not ordinary looking-glasses show the pseudoscopic effect?

(5) What is the limit of distance for pseudoscopic vision?

EXPERIMENT XXIX

§ 44. **Visual Space Perception: the Geometrical Optical Illusions.** — An ‘illusion’ may be defined as a “subjective perversion of the contents of objective perception” (Külpe). A visual illusion, then, is a perception which differs in some way from the perception which the nature of the visual stimuli would lead us to expect. All four sides of a square are equal. We should, therefore, expect that these sides would ‘look’ equal in the square figure. As a matter of fact, a perfect square always seems to be higher than it is broad. There is a discrepancy between the immediate perception of the ‘seeing eye’ and the later verdict of the ‘mathematical’ or ‘measuring eye.’ It is, plainly, the business of experimental psychology to enquire into the conditions of this discrepancy.

The illusions which we are here to consider manifest themselves in an “erroneous apprehension of spatial distances, directions, and differences of direction” (Wundt). They are given, in their very simplest form, in certain geometrical figures, and were therefore named by their discoverer, J. J. Oppel (1815–1894), ‘geometrical optical illusions.’ Since the date of Oppel’s first paper on the subject (1854–5), a very extensive literature has grown up, and attempts have been made to group the phenomena together, systematically, and to find basal principles of explanation. (1) One such attempt, that of Th. Lipps, Professor of Philosophy at Munich, sets out from a

law of 'mechanical-æsthetic unity,' which declares that every spatial form is endowed by us, in idea, with a living personality, or is regarded as the scene of the interplay of opposing mechanical forces. Thus the circle results from the counter action of two sets of forces, radial and tangential. The radial forces are the stronger; and the figure consequently has a centripetal character, seems always to be successfully 'holding itself together,' and so tends to be underestimated. The horizontal line seems, on the one hand, to be spreading itself out, and on the other to be strictly confined within its limiting points; and it depends on circumstances whether the one or the other 'striving' prevail, whether the length of the line is overestimated or underestimated. There is no illusion of perception, according to Lipps; we see the figures as they are drawn; but when we come to compare, to judge, to estimate, we are subject to illusion because influenced, unconsciously, by our 'anthropomorphic' attitude to the figures. (2) Another systematic attempt at explanation is that of Wundt. Wundt regards the illusions as matters of perception, not of judgment. It is not that we see aright but judge wrongly; we actually see illusorily. The conditions of the discrepancy between perception and stimulus-complex are to be sought in the laws of retinal image (fixation) and eye-movement.

We shall ourselves — as, indeed, the reader will have inferred from our preliminary definitions — follow Wundt's treatment. In doing this, we do not commit ourselves to the belief that all of Wundt's analyses are necessarily correct or adequate. It may quite well be the case that "many [illusions], even of those that seem most simple, are the resultant of several simultaneous tendencies" (Sanford), and that Wundt's principles ought, accordingly, to be supplemented by others. But there can be no doubt that the illusions in question are perceptions; and, even if we were in doubt upon the point, it would be our duty, as a matter of method, to seek a psychophysical theory of them before we had recourse to a purely psychological (to say nothing of an æsthetic) theory. As Wundt puts it: "Whenever a phenomenon in the sphere of sense-perception is due to the coöperation of physiological and psychological

conditions, the rule is (apart from special reasons to the contrary) that the physiological conditions are to be regarded as the primary."

EXPERIMENT (I). *Illusions of Reversible Perspective.*—All figures in which perspective elements are involved should be examined monocularly, not binocularly (see answer to Question 12, Exp. XXVII., above). In order to eliminate still more completely the suggestion of diagrams on a plane surface, the figures should be drawn in white lines on a black ground, and not in black on white. The black background suggests roominess,

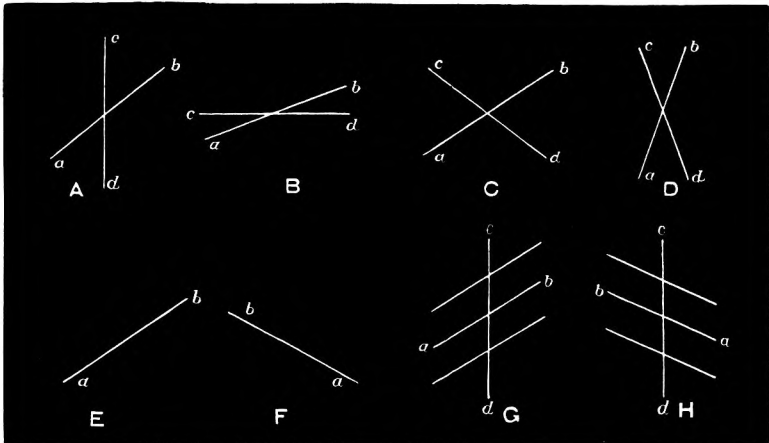

FIG. 29.—Hering's Crosses.

spaciousness, as certainly as the white paper surface suggests a plane projection.

(i.) Fixate the point *a* in *A* and *B* of Fig. 29. What is its position relatively to the plane of *cd*? Does its position remain fixed so long as fixation is steady? Move the eye slowly along the line *ab* to *b*. Does the position of *ab* remain constant? Does that of *cd* remain constant?

Fixate *a* in *C* and *D*. What happens? Does the position of *cd* remain the same? Fixate *b*. What happens? What of *cd*?

Fixate *a* and *b* successively in *E* and *F*. Is there any illusion? Is there anything special to be noted about it?

What illusions are possible with *G* and *H*?

(ii.) The diagrams of Fig. 30 are simple modifications of those of Fig. 29. How does the figure *A* strike you at first sight? Fixate some point on *be*. What is the appearance of the figure? Move the eye slowly from *b* to *e*, and back again. Does the figure change its perspective? Move the eye from *b* to *c*, and back again. Is there any change? Is there any uniformity of perspective, according as you move in the directions *bc*, *ba*, *ef*, *ed*, or in the opposite directions?

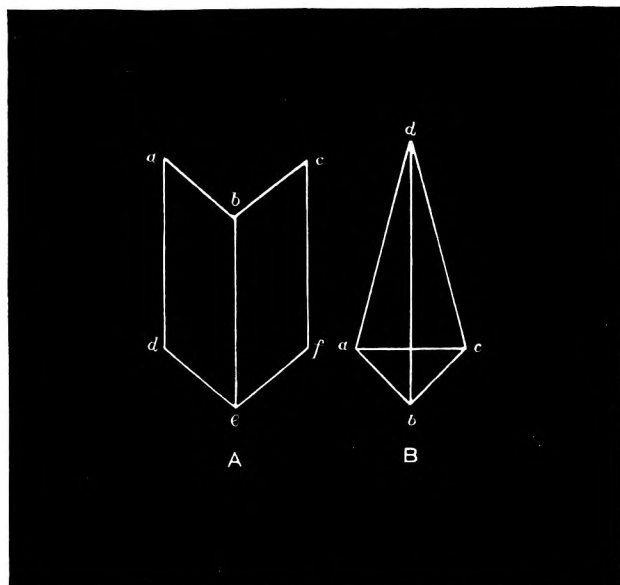

FIG. 30.

How does the figure *B* strike you at first sight? Fixate, first, a point upon *bd*, and then a point upon *ac*, *ad* or *cd*. Is there any difference of perspective? Move the eye slowly in the direction *ba* or *bc*; and then in the direction *ab* or *cb*. What happens in the two cases? What secondary modifications of the appearance of the figure are conditioned upon the shift of perspective? How many perspective illusions, in all, is the figure capable of producing?

(iii.) Fig. 31 may be seen either as a flight of steps, or as the underside of such a flight (or a piece of overhanging masonry,

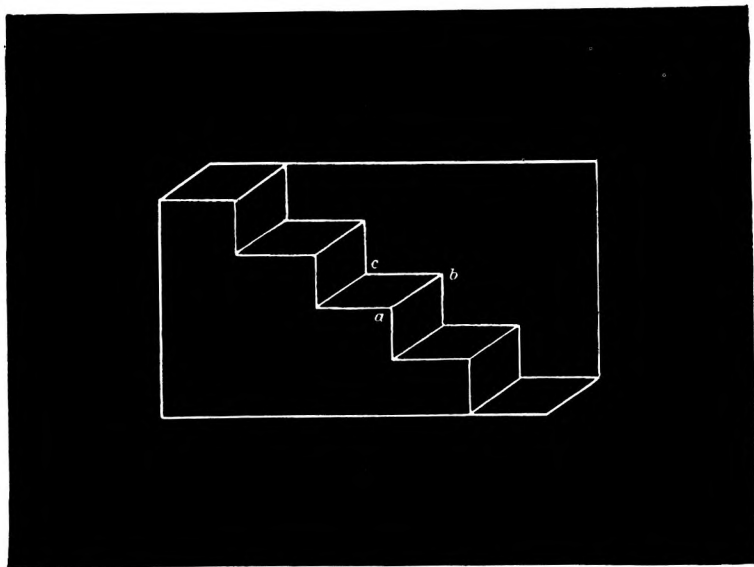

FIG. 31. — Schröder's Stair Figure.

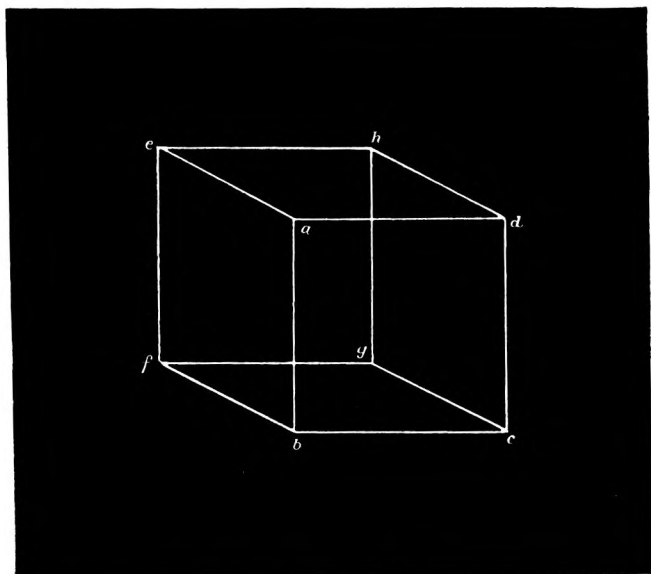

FIG. 32. — Necker's Cube.

with stones or bricks broken out in regular succession). Under what conditions of fixation and eye movement do the two perceptions occur?

(iv.) Fig. 32 may be seen either with the face *abcd* or with the surface *efgh* nearer the observer. Carefully describe the conditions and accompaniments of the change of perspective. What is the effect of turning the figure to right or left through 90° ? What other illusions may the figure produce? Under what conditions?

(v.) In the figures hitherto considered, the two conditions of

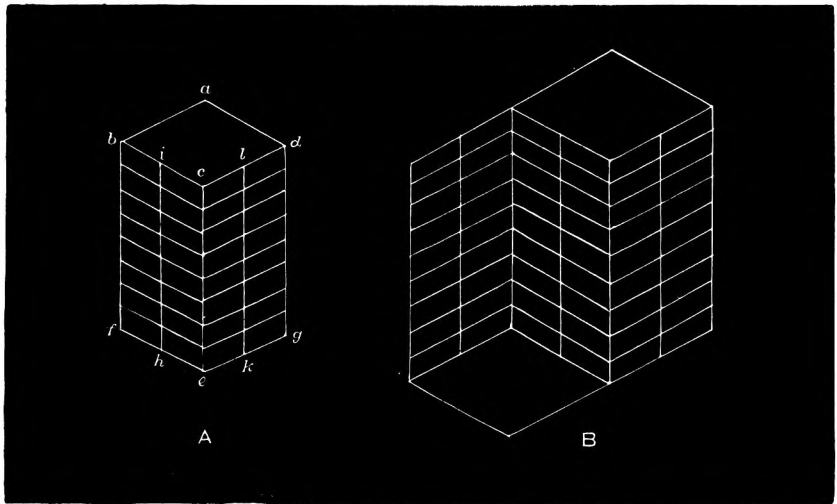

FIG. 33.—Thiéry's Prisms.

perspective interpretation, fixation and eye movement, have reinforced each other. Fixation of a point or edge has given a certain plastic effect, and this effect has been increased by movement of the eye along a line of fixation. In Fig. 33 we have an apparent opposition of the two motives: the effect of fixation is reversed by the eye movement which should reinforce it. There is, however, a simple explanation of the seeming anomaly. The figures are so constructed that movement of the eye along a fixation line necessarily ends in a position of fixation which converts the relief; the perspective interpretation is, in the

nature of the case, conditioned upon fixation and not upon eye movement.

Fixate the centre of the surface $abcd$ in A . How do you see the figure? Fixate a point on ce ; then a point on bf or dg . What are the illusions? Move the eye out, from ce , along an oblique line: then in, from bf or dg , along an oblique line. What is the

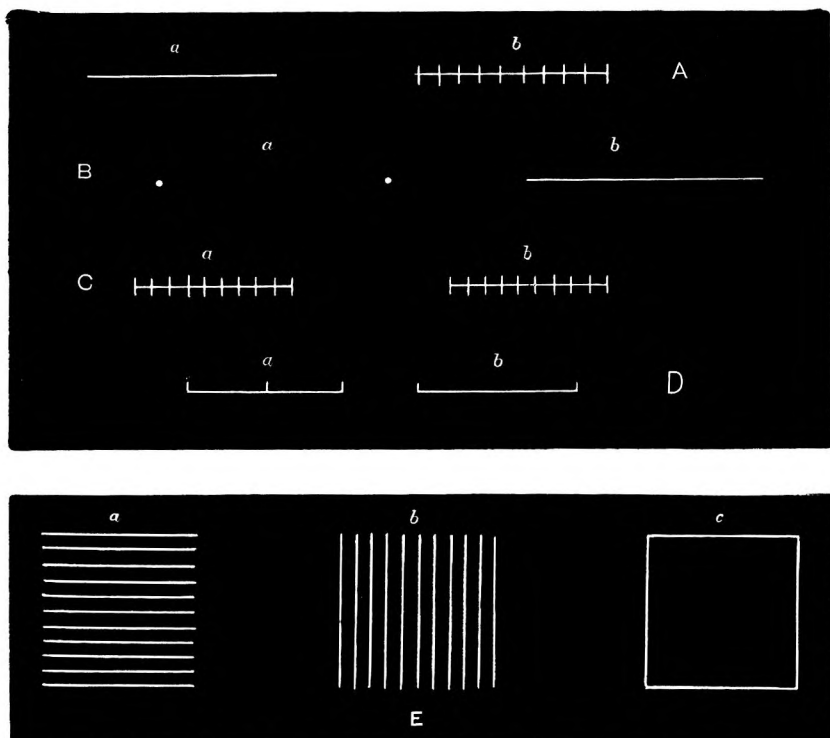

FIG. 34.—Oppel's Lines and Helmholtz' Squares.

result? Move the eye slowly up and down hi or kl : then let it move in or out, along an oblique line. Is there anything irregular or anomalous in the general results?

Analyse, in the same way, the illusions producible by B .

EXPERIMENT (2). *Variable Illusions of Extent*.—(vi.) Look at the figures of Fig. 34, in the way that seems most natural to you. What is the first thing, in the way of illusion, that strikes you

about them? Which is the longer line in *A*, *a* or *b*? Is the distance *a* or the line *b* longer, in *B*? In *C*, is the central space longer or shorter than *a* and *b*? In *D*, is *a* or *b* the longer?

Do these four figures show any illusion of perspective? If so, what is it? Do any of the figures indicate whether the illusion of extent is primary and the illusion of perspective secondary (conditioned upon the illusion of extent), or *vice versa*?

Which is better for the extent illusions, fixation or eye movement? Which is better for the perspective illusions? What is the effect of turning the figures through 90° ?

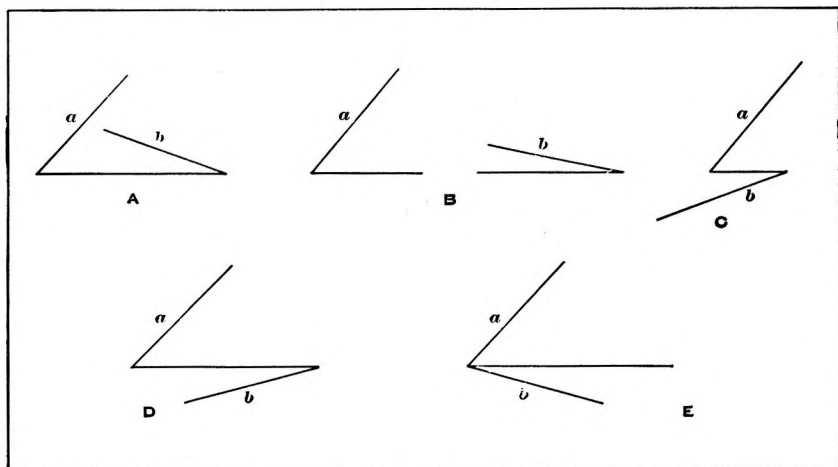

FIG. 35. — Láska's Figure and variants.

What light is thrown by the three figures of *E* upon the question whether the illusion of extent or the illusion of perspective is the primary?

Summarise the conditions of illusion (illusion of extent) in these figures.

(vii.) In all five figures of Fig. 35, the lines *a* and *b* are objectively equal. Do they appear equal? What is your method of estimating their relative length?

(viii.) The two verticals in *A* and *B*, and the two middle lines of *C*, in Fig. 36, are all equal. Do they appear equal? In which

of the three figures is the illusion of extent most marked? Do the figures show any perspective illusion? If so, is it reversible or irreversible?

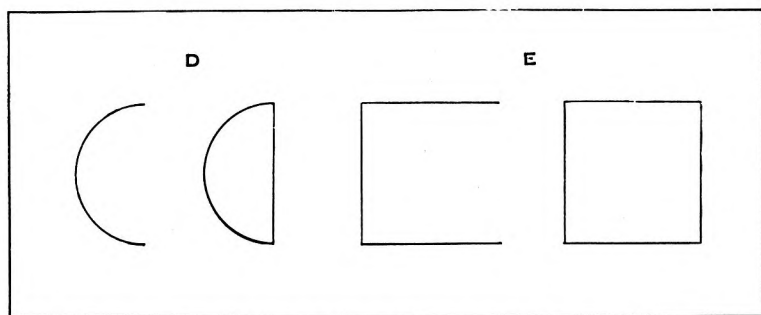
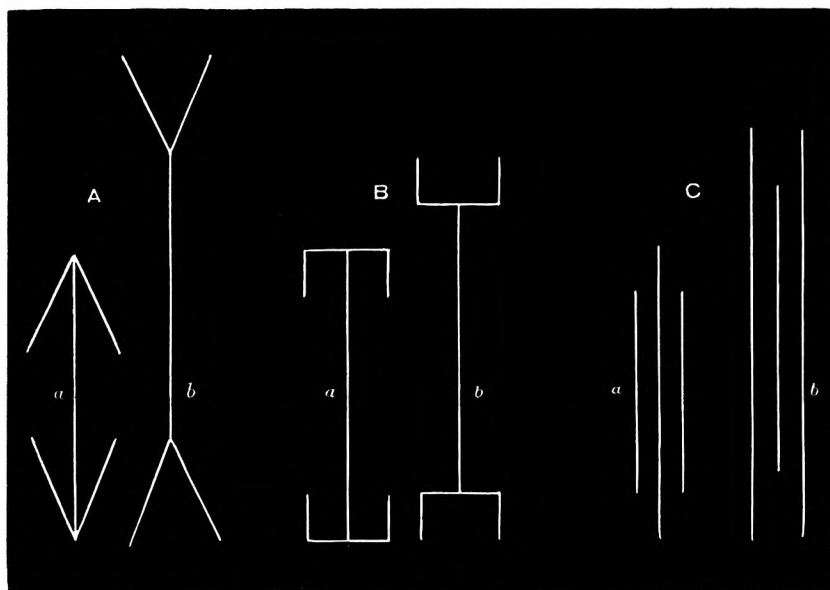

FIG. 36. — The Müller-Lyer illusion.

What is the influence of eye movement and of steady fixation upon the illusion of extent? Upon the illusion of perspective? What is the effect of turning the figures through 90° ?

Summarise the conditions of illusion in the three figures. Can the illusions of *D* and *E* be subsumed under the same conditions?

EXPERIMENT (3). *Constant Illusions of Extent.* —(ix.) In this group, we have no illusions of perspective.

Observe *A* of Fig. 37 binocularly. Is there any illusion of extent? Observe the figure monocularly. Is there any other

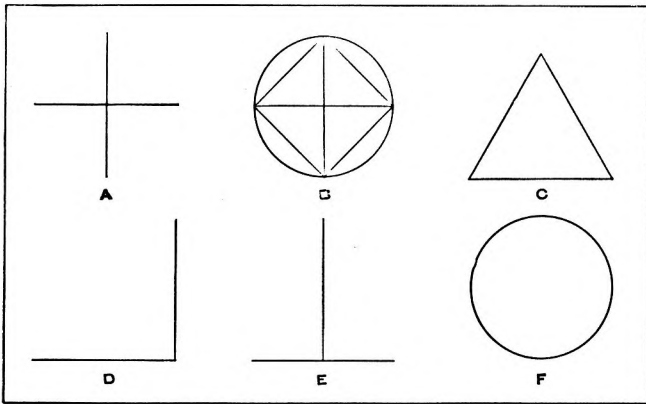

FIG. 37. — The illusions of Oppel, Delbœuf and Kundt.

illusion? Look very carefully, in both cases, and do not be satisfied with your first discovery.

What illusions do *B*, *C*, *D* and *E* present, when viewed binocularly? Do *B* and *E* show any further illusion, when viewed monocularly? Can you suggest any explanation of these illusions? Does the absence of illusion in *F* help you?

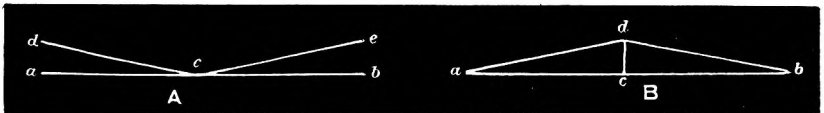

FIG. 38. — Oppel's Angles.

EXPERIMENT (4). *Variable Illusions of Direction.* —(x.) The lines *ab* in *A* and *B* of Fig. 38 are straight. Do they appear so, as the eye moves along them? Fixate *c*. Is there any illusion of perspective in the two figures? Do not be satisfied with a first description.

Under what general formula may the illusions of direction be subsumed? Is the illusion of direction or the illusion of per-

spective primary? Why? Can you reinforce your conclusion by appeal to any Figure that you have considered in a previous experiment?

(xi.) Move the eye along the parallels *ab*, *cd*, in *A* and *B* of

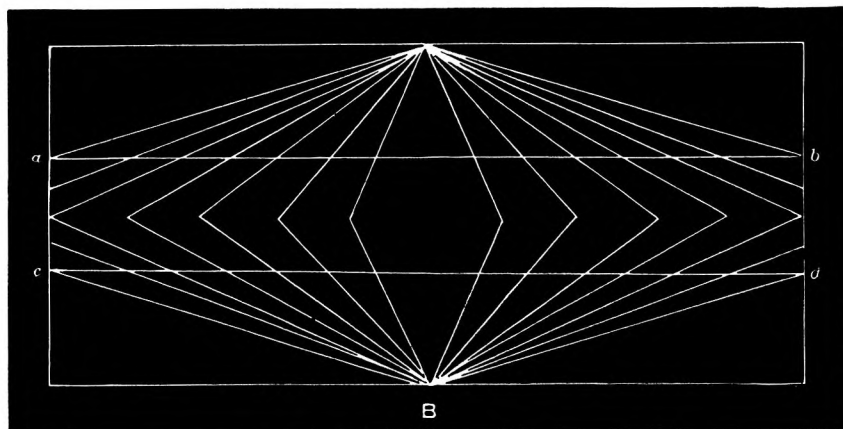
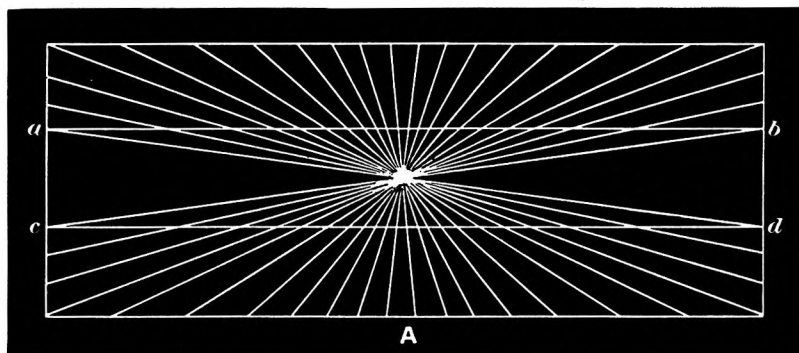

FIG. 39. — The Figures of Hering and Wundt.

Fig. 39. What is the illusion of direction? Where is it strongest? Why do we have opposite illusions in the two figures?

What is the illusion of perspective in these figures? Does it remain unchanged, whether we allow the eye to move or maintain a steady fixation?

(xii.) What illusions of direction do you observe in *A* and *B* of Fig. 40? Look carefully. Can you account for them in the light of the preceding figures of this experiment?

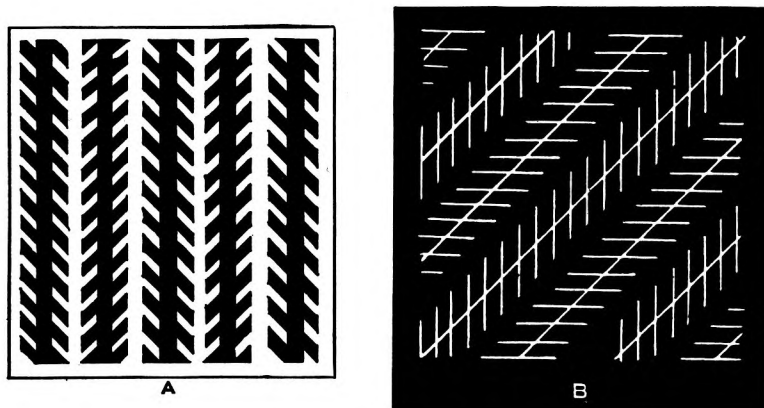

FIG. 40.—Zöllner's Figure.

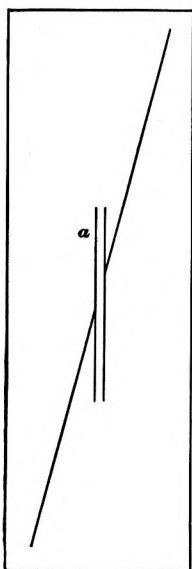

FIG. 41.—Poggen-dorff's illusion.

Is there any illusion of perspective? Is it, or is the illusion of direction, affected by a change from eye movement to fixation?

(xiii.) How does Fig. 41 strike you at first sight? Move the eye up and down the lines *a*. Does the illusion of direction change? Is there any illusion of perspective? Under what conditions does it appear?

Can you offer any general explanation, in terms of eye movement, of the illusions of this experiment?

EXPERIMENT (5). *Constant Illusions of Direction.*—(xiv.) We have already had an instance of these illusions in the deviation of the apparent retinal verticals from the objective vertical (p. 136).

Draw Fig. 42 \times 5 on a sheet of white paper, and set it up on a vertical screen at a distance of $d \times 5$ from the observing eye. Steadily

fixate the centre of the enlarged figure. What do you see? Is there any illusion of perspective?

Have you any explanation of the phenomena?

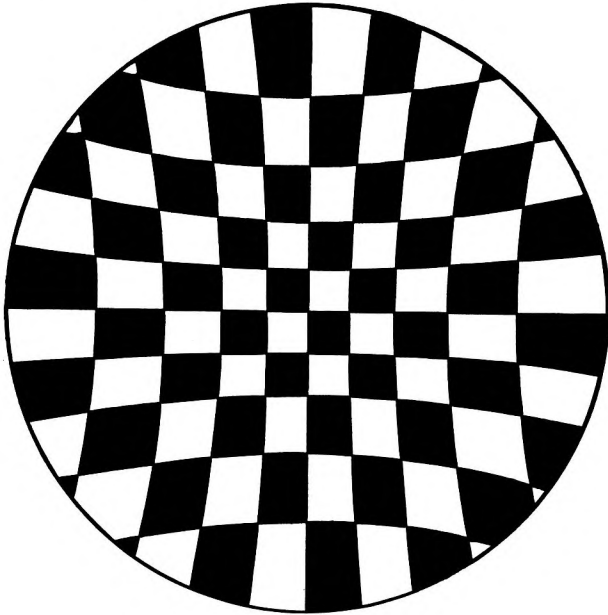

FIG. 42. — Helmholtz' Chess-board ; von Recklinghausen's illusion.

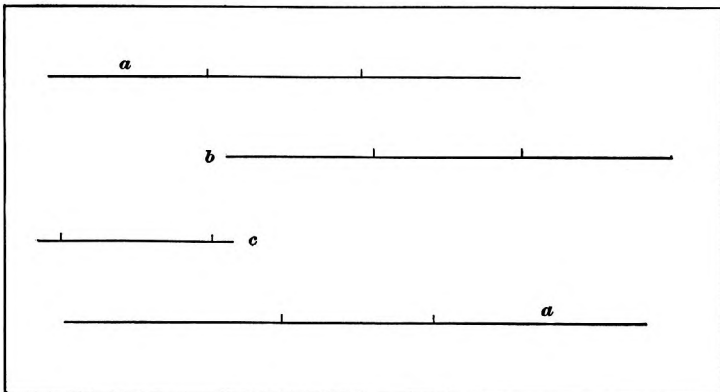

FIG. 43. — Wundt.

EXPERIMENT (6). *Illusions of Association*. —(xv.) Estimate the relative length of the middle portions of the lines *a*, *b*, *c*, *d* in Fig. 43. Classify them, in the order longest to shortest. Does the figure, or any part of it, show a perspective illusion?

Measure the middle lines and the side-pieces. Have you any explanation of the illusion?

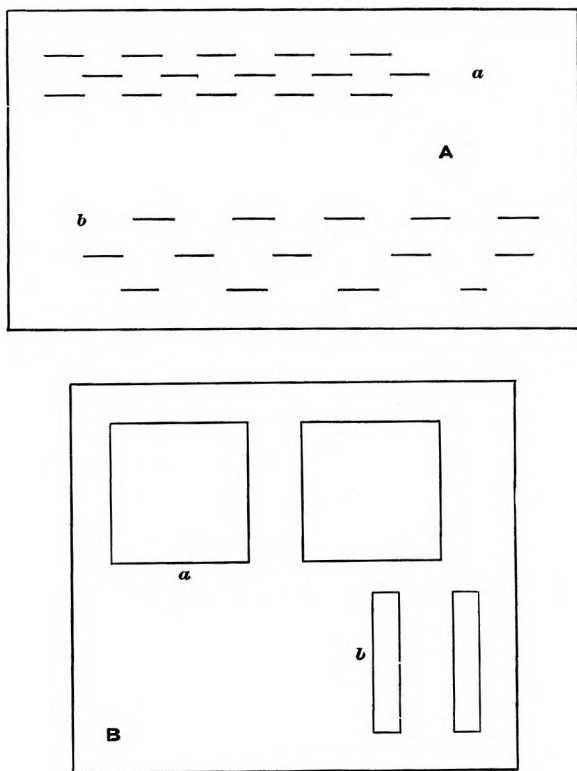

FIG. 44.—*A*, Wundt; *B*, Müller-Lyer.

(xvi.) Are the lines in *a* and *b* of *A* in Fig. 44 equal? Are the interspaces in *a* and *b* of *B* equal? Measure them. Have you an explanation?

EXPERIMENT (7). *Illusions with Complication of Conditions*. —(xvii.) What are the apparent dimensions of *A* in Fig. 45 as compared with those of *B*? How do you explain the illusion?

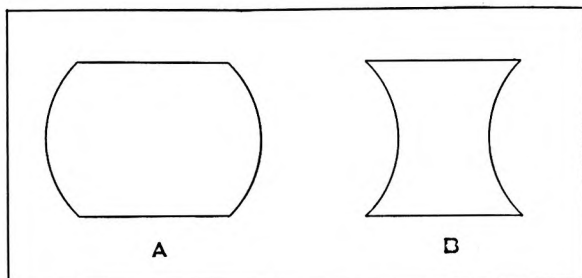

FIG. 45

(xviii.) What is the illusion of Fig. 46? Explain it.

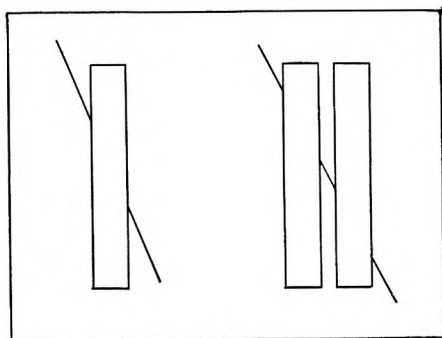

FIG. 46. — Poggendorff's illusion.

(xix.) What is the illusion of Fig. 47? Explain it.

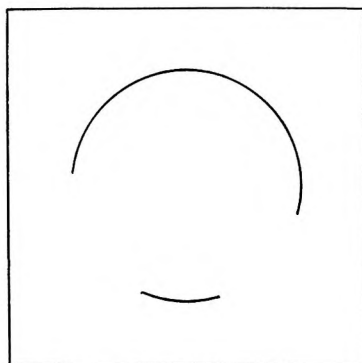

FIG. 47. — Müller-Lyer.

(xx.) What are the illusions of *A* and *B* in Fig. 48? Explain the former by reference to a single known condition, and the latter by reference to a complexity of conditions.

QUESTIONS. — (1) The two main factors in Wundt's explanation of the geometrical optical illusions are 'the character of the retinal image' and 'the movements of the eye.' Do you know of any divergence of these factors from the normal, that leads to disturbances of vision ('optical illusion' in a wider sense) in other fields of perception?

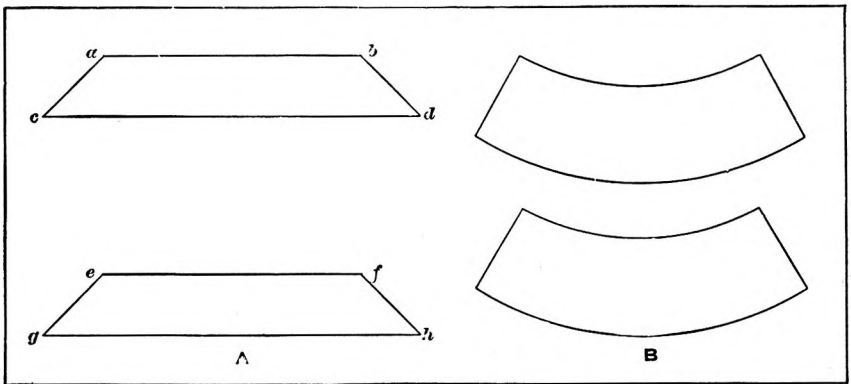

FIG. 48. — *A*, Müller-Lyer ; *B*, Wundt.

(2) Classify the geometrical optical illusions by their conditions, in the order purely physiological to purely psychological.

(3) What is meant by 'assimilation of ideational elements' in Wundt's psychology?

(4) What are the secondary, psychological conditions of the illusions of reversible perspective?

(5) What different meanings may attach to the phrase: "overestimation of acute, and underestimation of obtuse angles"?

(6) Summarise the arguments for and against the views that the geometrical optical illusions are matters (a) of perception, (b) of judgment.

(7) Describe and explain the illusions of Figs. 49–53.

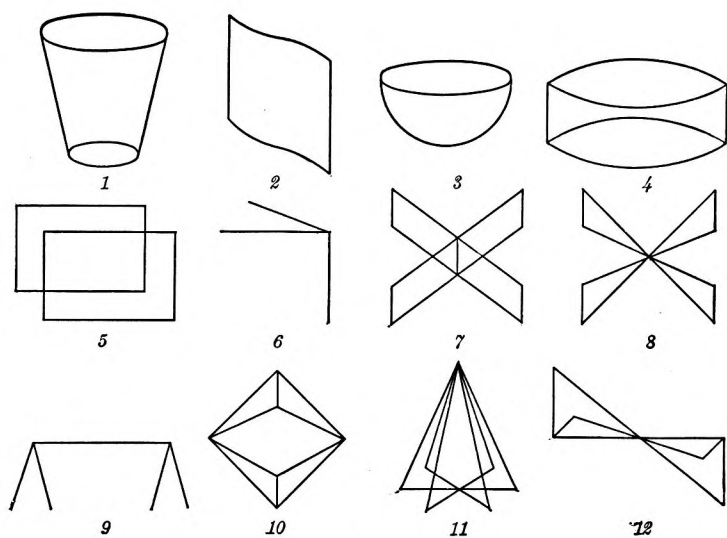

FIG. 49.

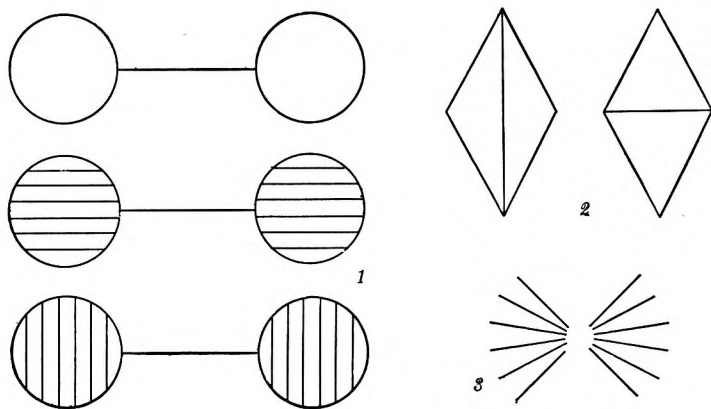

FIG. 50.

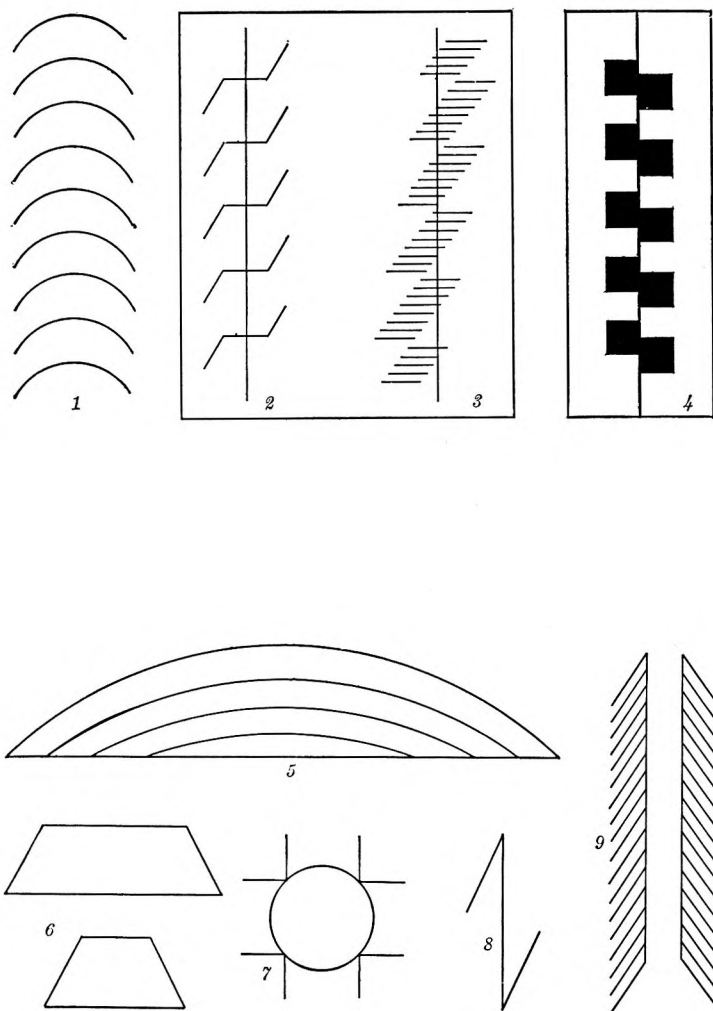

FIG. 51.

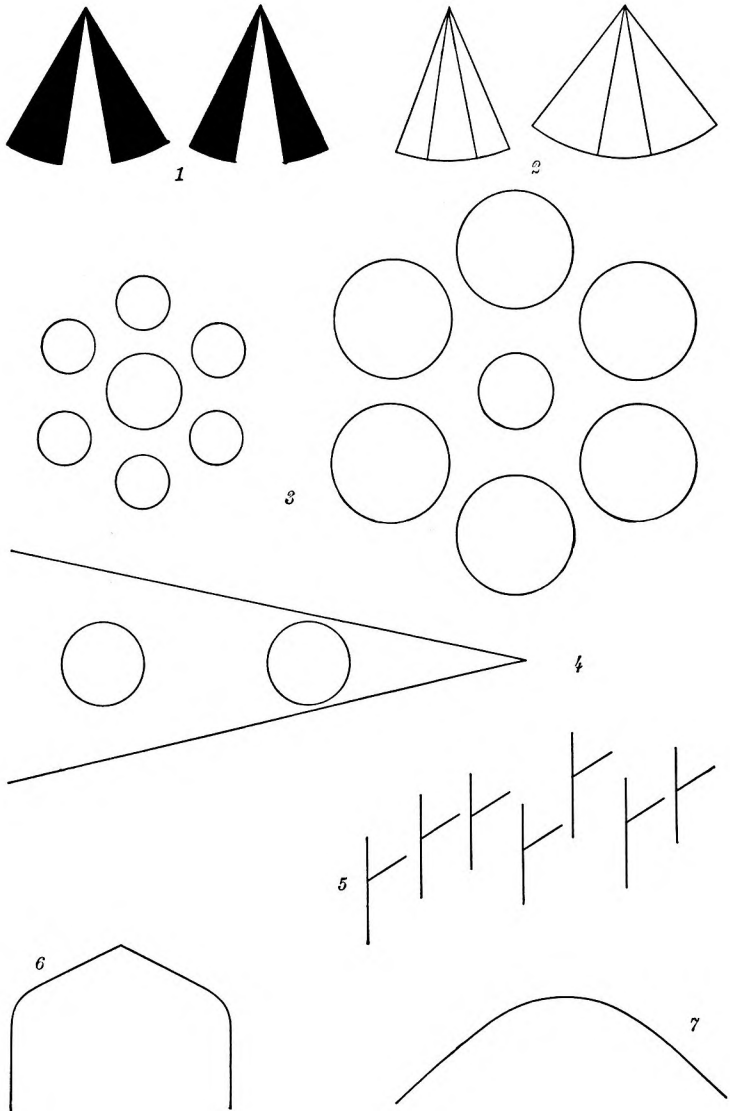

FIG. 52.

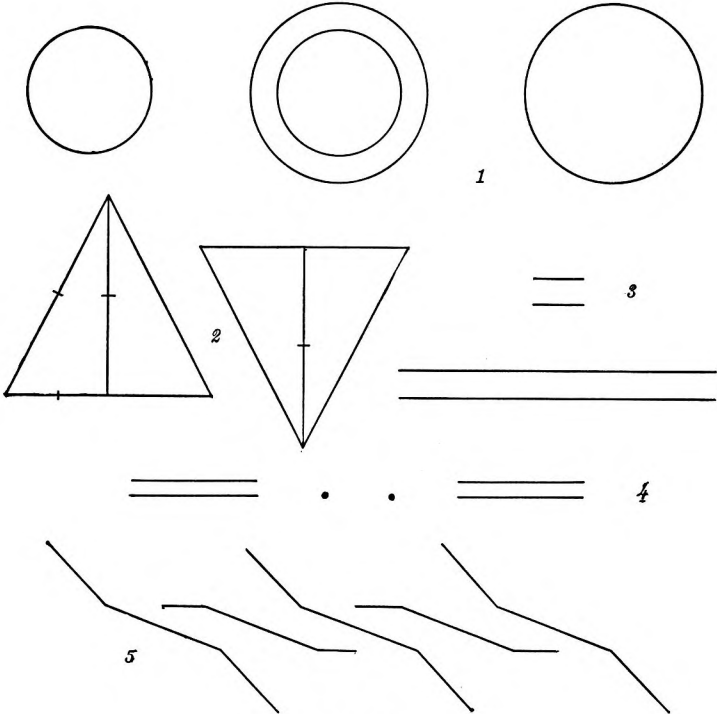

FIG. 53.

CHAPTER X

AUDITORY PERCEPTION

EXPERIMENT XXX

§ 45. **The Degrees of Tonal Fusion.** — Suppose that two simple tones are sounded together. The resultant perception (apart from beats and combination-tones) will differ very greatly, according to the pitch of the tones employed. It may be obviously complex, composite, so that even the unmusical observer has no hesitation in declaring that it 'contains' or 'is made up of' more than one simple tone. On the other hand, it may approach so closely to the singleness and simplicity of sensation, that even a musical observer will, now and again, take it for a simple tone.

The same rule holds of simple clangs. If two notes are sounded together, upon a musical instrument, the resultant sound-mass may be heard as compounded of more than one note, or may be indistinguishable in perception from the sound of a single note.

The perception set up in this way, by the concurrence of a number of simple tonal stimuli, is termed a 'tonal fusion' (German *Verschmelzung*). Since the fusion presents all grades, from obvious complexity to a simplicity that counterfeits the simplicity of sensation, we may speak of a *scale of fusion degrees*. That fusion is the most perfect, which is most unitary in perception; that fusion is the least perfect, whose components fall apart most readily in perception.

The object of the present experiment is to establish the scale of fusion degrees within the octave, by sounding together the constituents of all the musical intervals, from the minor second to the octave itself, and arranging the perceptions in the order from most to least unitary.

MATERIALS. — Five harmonicas (mouth-organs), marked *c*, *d*, *e*, *f*, *a*. A glass Y-tube; two short pieces of rubber tubing, to fit over the arms of the tube; quills or short glass tubes to fit over the holes of the harmonicas. [The mouth-organs recommended for this experiment give the common chord in three successive octaves. The *c*-organ gives the notes c^1 , e^1 , g^1 , etc.; the *d*-organ gives d^1 , $f^1 \sharp$, a^1 , etc.; the *e*-organ, e^1 , $g^1 \sharp$, b^1 , etc.; the *f*-organ, f^1 , a^1 , c^2 , etc.; the *a*-organ, a , $c^1 \sharp$, e^1 , etc. The intervals within the octave may, therefore, be found as follows:

Octave	<i>c</i> -organ	1st hole	<i>c</i> -organ	4th hole	c^1-c^2
Major second . .	"	1st "	<i>d</i> -organ	1st "	c^1-d^1
Minor second . .	<i>a</i> -organ	2d "	"	1st "	$c^1 \sharp-d^1$
Major third . . .	<i>c</i> -organ	1st "	<i>c</i> -organ	3d "	c^1-e^1
Minor third . . .	<i>a</i> -organ	2d "	"	3d "	$c^1 \sharp-e^1$
Fourth	<i>c</i> -organ	1st "	<i>f</i> -organ	1st "	c^1-f^1
Tritone	"	1st "	<i>d</i> -organ	2d "	$c^1-f^1 \sharp$
Fifth	"	1st "	<i>c</i> -organ	3d "	c^1-g^1
Major sixth . . .	"	1st "	<i>d</i> -organ	3d "	c^1-a^1
Minor sixth . . .	<i>a</i> -organ	2d "	"	3d "	$c^1 \sharp-a^1$
Major seventh . .	<i>c</i> -organ	1st "	<i>e</i> -organ	3d "	c^1-b^1
Minor seventh . .	<i>a</i> -organ	2d "	"	3d "	$c^1 \sharp-b^1$

The instruments should be set up in a wooden frame, for convenience of handling. The stem of the Y-tube serves as mouth-piece; the rubber tubing connects its arms to the quills, which fit into the holes of the organ.]

PRELIMINARIES. — *O* must be familiarised with the tone of the instruments, and *E* must have practice in sustained and even blowing. It is, therefore, advisable to spend some little time upon this preliminary work. *E* should sound only one note at a time; the free end of the connecting tubes may be corked.

EXPERIMENT. — *O* is told that he will be given (*a*) single notes, and (*b*) two-note complexes, in irregular order, from various parts of the octave. He is required in each case to say (or to write down on paper) whether the sound which he hears is that of one note or of more than one note. In case of doubt, he is

to say 'doubtful' (or write the sign ?), stating at the same time the direction in which his judgment inclines.

At the signal "Now!" *O* closes his eyes, and awaits the stimulus. *E* sounds the note or notes for 2 sec. *O* records his judgment, and the experiment is repeated. The time-interval between test and test should be kept as constant as possible. No fixed rule can be laid down for it; but three series of 25 tests each, with short pauses for rest between them, may be taken in the hour. At least 25 trials should be made with each of the 12 musical intervals (300 tests in all).

RESULTS. — There will, probably, be some intervals which are invariably heard as more than one note, *i.e.*, which are 'judged correctly' by *O* in every instance. On the other hand, there will perhaps be some intervals which are invariably heard as one note. *E* tabulates the intervals, in the order from highest to lowest percentage of errors. The first line of the Table will give the most perfect, the last line the least perfect fusions; the intermediate lines show the intermediate fusion degrees.

QUESTIONS AND COGNATE EXPERIMENTS. — (1) How many degrees of fusion are distinguishable within the octave? Are the different degrees separated by equal or by unequal steps or distances?

(2) Formulate the general law of tonal fusion.

(3) Is the degree of fusion of two tones dependent upon the tone region (the part of the musical scale) from which the tones are taken?

(4) Is the degree of fusion dependent upon the (absolute or relative) intensity of the component tones?

(5) How is fusion degree affected by extension of the intervals beyond the octave? Is there, *e.g.*, any difference between the fusion degree of the fifth and that of the twelfth?

(6) How is fusion degree affected by the addition of a third, fourth, etc., tone to the two primary tones?

(7) How is fusion degree affected by a spatial separation (different localisation) of the two tones?

(8) Can you ideate (imagine, think of) two simultaneously sounding tones in any other than their perceptual degree of fusion?

- (9) What are the principal conditions of the analysis of a tonal complex?
- (10) What is the 'pitch' of a two-tone fusion?

EXPERIMENT XXXI

§ 46. **Rhythm.** — Rhythm (Gk. *ῥυθμός*, literally 'flow') has been defined from the objective standpoint as "movement in time, characterised by equality of measures and by alternation of tension (stress) and relaxation" (Cent. Dict.). We may define it from the subjective standpoint as a temporal perception, which is characterised for introspection by the fact that its component sensations (*a*) recur at regular intervals and (*b*) evince a regular variation of intensity. The essential thing in the perception of rhythm is the "running together of the impressions to form organic groups" (Bolton); the "subjective bringing-together of the impressions to form a whole" (Meumann); the apprehension of each term (*arsis* or *thesis*) in the rhythmical series as a repetition of the preceding *arsis* or *thesis* and a preparation for the following *thesis* or *arsis* (Wundt).

There are only two classes of sensation that can form the basis of the perception of rhythm. These are the auditory and the tactual or 'motor': there can no more be, *e.g.*, a visual rhythm than there can be an auditory symmetry. The tactual rhythms are, perhaps, older in the history of mind than the auditory. On the other hand, auditory stimuli present great advantages for investigation. Whereas muscular movements are limited by the mechanical construction of the limbs, the nature of their attachment to the trunk, etc., sounds can be freely varied; their variation as regards duration, time-interval, intensity, quality and clang-tint, is easily regulated; and while tactual intervals must necessarily be filled, the intervals which are bounded by sounds may be either filled or empty. It is natural, then, that we choose a succession of sounds as our rhythm-stimulus.

We must begin with sounds that are simple in character, and intrinsically uninteresting, — not possessed of any attribute that may attract the attention to them and away from their

succession. We shall, therefore, choose noises rather than tones. Furthermore, we must begin not with a highly rhythmical series, but with a series that offers the lowest limit or zero-point of objective rhythm; we can then work up from this, bringing in one rhythmical factor after another, until all the conditions are present that normally coöperate to produce the rhythmical effect. Such a series is found in a perfectly uniform succession of noises; a series in which there is absolutely no variation of intensity, quality, duration or time-interval.

Our first problem, then, is to lay before *O* an uniform series of noises, and to see what he does with it, what sort of perception it arouses.

MATERIALS. — **Metronome.** Felt. [The metronome consists in essentials of a short pendulum, driven by clock-work, and ticking loudly at each beat. The rate of the ticks can be varied, by means of a sliding weight upon the shaft of the pendulum, between the limits 40 and 208 in the minute: 39 different settings are indicated on the scale.]

PRELIMINARIES. — The customary tick of the metronome, as it stands upon table or piano, may be described as a noisy clang or a metallic clack. To deaden the sound, *i.e.*, to eliminate the clang elements, *E* must remove the floor of the clock-chamber (it comes away when a button is turned), and set the instrument upon a layer of thick felt. The tick then becomes a mere click or crack.

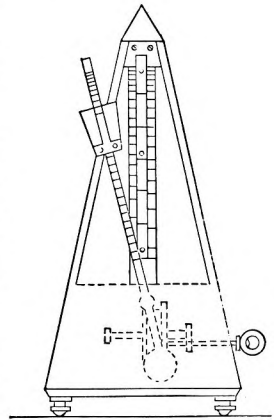

FIG. 54.

The table on which the metronome stands must be placed in such a relation to *O* that there is no echo or reverberation from the walls of the room. The ticks are to form a series of sharply separated dead sounds.

Six rates of ticking are to be used in the following experiments :

Setting.	Interval between Clicks.
42	1.4 sec.
48	1.2 "
66	.9 "
92	.65 "
152	.39 "
200	.3 "

EXPERIMENT (1). — *O* sits with his back to the metronome, at a distance of some 2 m. After the ready signal, *E* starts the metronome at one of the two quickest rates (.39 or .30 sec. intervals), and lets it run for 45 sec. *O* is to give himself up, quite passively, to the impression of the sound series, and is to describe what he hears.

The experiment should be repeated three times with each of the rates. There must be a pause of at least 5 min. between series and series. The introspective record should be made as full as possible.

EXPERIMENT (2). — The experiment is performed with all six rates, taken in irregular order, and each twice repeated.

EXPERIMENT (3). — Experiment (2) is repeated, but under slightly different conditions. Ask the Instructor for directions.

The following Questions arise.

E (1) Summarise the results (*a*) of exps. (1) and (2), and (*b*) of exp. (3).

O (2) What are the characteristics of the s. a. consciousness? [The Instructor will explain the abbreviation.]

We have now to differentiate our series of clicks, and so to study the various objective factors in rhythmisation. We may introduce four simple changes: changes of intensity, changes of time-interval, changes of duration and changes of quality. We begin with intensity.

MATERIALS. — Metronome and felt, as before. Metronome box. [This is a padded box, large enough to contain the metronome, with a hinged lid. The under surface of the lid is padded, so that it makes no sound in falling. The lid must

move noiselessly and easily on its hinges ; it is pulled up by a ring or strap. A string loop passes over two nails, driven the one in the side of the box and the other in the edge of the lid, so that the lid itself can be raised only to a certain constant height.]

PRELIMINARIES. — When the box is closed, the sound of the metronome beats is very considerably weakened. By pulling up the lid at regular intervals, *E* can introduce an intensive beat at any desired point of the series. He should practise with the three settings 152, 176 and 200 (.39, .34 and .3 sec. intervals).

EXPERIMENT (4). — *O* sits with his back to the box. *E* sounds the following accented series, in irregular order. If time permit, every series should be given twice over, at all three rates.

I'	I		I'	I		.	.	.						
I	I'		I	I'		.	.	.						
I'	I	I		I'	I	I		.	.	.				
I	I	I'		I	I	I'		.	.	.				
I	I'	I		I	I'	I		.	.	.				
I'	I	I	I		I'	I	I	I		.	.	.		
I'	I'	I	I		I'	I'	I	I		.	.	.		
I	I	I	I'		I	I	I	I'		.	.	.		
I'	I	I	I	I		I'	I	I	I	I		.	.	.
I'	I	I'	I	I		I'	I	I'	I	I		.	.	.
I'	I'	I	I'	I		I'	I'	I	I'	I		.	.	.

We lay these accented series of sounds before *O*, in order to see, again, 'what he does with them,' what sort of perceptions they arouse. *O* must be guided, in the report of his introspections, by the experience already gained in exps. (1)–(3).

Question (3) *E*. Is there any general rule or principle of mental grouping under which the results of this experiment can be subsumed?

E (4) What light does the experiment throw upon the mechanics of the rhythm-consciousness?

EXPERIMENT (5). — This experiment is most simply performed on the piano. *O* seats himself with his back to the instrument. *E* sounds a series of notes, as directed by the Instructor. *O* reports the nature of the perception aroused.

EXPERIMENT (6). — This experiment may be performed either on the piano or with the metronome, as the Instructor directs. *O* reports as before.

EXPERIMENT (7). — Here, again, we have recourse to the piano. Directions and reports are as before.

Question (5) *E*. How do the results of these three experiments affect the answer to Question (4)? What further introspective problem do they suggest?

The following Questions may now be attempted.

E and *O* (6) What is rhythm? To what class or group of mental formations does it belong? Give reasons for your answer.

E and *O* (7) Outline a programme of further work upon the psychology of rhythm.

E and *O* (8) How does rhythm in music differ from rhythm in qualitatively similar sound-impressions?

E and *O* (9) If there is no such thing as a visual rhythm, how do you account for the distinctly rhythmical impression produced by the beams of a vaulted ceiling, the row of capitals on a façade, etc.?

E and *O* (10) What is the fundamental rhythmical form or measure? What rhythmical forms do music and poetry employ?

E and *O* (11) Give a theory of the origin of the rhythmical perception.

EXPERIMENT XXXII

§ 47. **The Localisation of Sound.** — We localise the familiar sounds of everyday life as regularly and as confidently as we localise sights and touches. They come to us with a certain direction and a certain distance upon them; they belong to this point or that in objective space. It is, however, noteworthy that the objective space to which we refer them is not a sound space but *visual* space. This fact alone suggests that the localisation of sound is not an original form of perception, but rather something derived and secondary. We shall ask, in the present experiment: (i.) How accurate is our estimate of the direction of a given sound? And (ii.) what means have we of determining its direction? What is the mental mechanism of sound localisation?

MATERIALS.—Sound cage, with telephone receiver, key and battery. Rod, 50 cm. in length. Two cardboard semicircles, 20 cm. in diameter, graduated in hundredths. [The sound cage

consists, in essentials, of (a) a heavy iron standard, which carries (b) an adjustable head-clip, (c) a semicircle of heavy brass wire, 102 cm. in diameter, rotating freely about a vertical axis, and (d) a similar semicircle, just fitting within the larger, and rotating freely about a horizontal axis. The head-clip is so placed that the common centre of the two semicircles

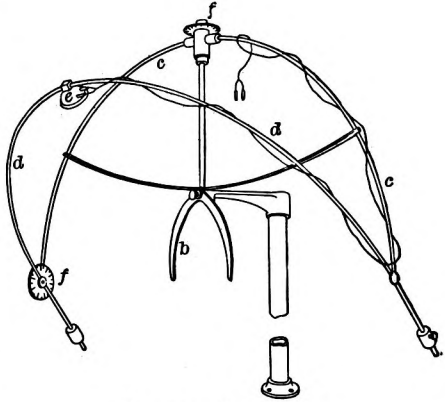

FIG. 55.—Sound cage.
Michigan App. Co., \$16.00.

coincides with the centre of the imaginary line joining *O*'s two ears. The telephone receiver is permanently wired to the middle point of the smaller semicircle, and is connected in series, by way of the key, to three Leclanché cells.

It is plain that, if the larger semicircle be clamped transversely, the receiver can describe a complete circle in the median plane of *O*'s body, except for the arc which it is prevented from traversing, in front by *O*'s knees, and behind by the iron standard. If the larger semicircle be clamped in the sagittal direction, the receiver describes a complete circle in the transverse or frontal plane, *minus* a similar arc which it is prevented from traversing by the sides of *O*'s chair. If it be set at the various intermediate positions, the receiver can be brought (with the exceptions just mentioned) to any point upon the surface of the sphere about whose centre the two semicircles turn. Each semicircle is provided with a pointer and a disc graduated in hundredths. The zero-point upon these discs corresponds to an exactly vertical position and transverse direction of the two semicircles (receiver at the vertex). Readings in the vertical plane (movement about the horizontal axis) are taken from above downwards: the point

0 is directly above the head, and the point 25 in the horizontal plane of the ears; 40 is the lowest point available for the experiment. Readings in the horizontal plane (movement about the vertical axis) are taken from the median line rightwards, as the clock-hand moves. Thus the point 0 lies in the median plane of *O*'s body, directly before his face; 25 is opposite his right ear; 50 is in the median line behind his back; 75 is opposite his left ear. To illustrate: the reading 15-9 means that the receiver is placed 15 divisions down, and 9 divisions to the right; the reading 40-78 means that it is placed 40 divisions down (as far down as it will go), and 78 divisions to the right (*i.e.*, a little forward from *O*'s left ear). And so on.

There are various methods of localising. Simplest of all is the verbal: *O* translates his localisation, with closed eyes, into numerical terms, —forming as clear a visual idea as he can of the position and divisions of the semicircles. Localisation may also be tactual-visual. *O* opens his eyes, as soon as he has heard the telephone click, and points with the rod in the direction from which he thinks that the sound comes. This method is a little cumbrous. For *E* must evidently give the cage a turn, before *O* opens his eyes, in order that the receiver may not itself furnish the cue for localisation; and when *O* has pointed, *E* must again swing round the wire semicircles, until the receiver lies opposite the end of the rod, in order that he may take his readings. Thirdly, the localisation may be visual. *O* opens his eyes, after the telephone has clicked, holds up the cardboard semicircles before his face, and reads from them the supposed position of the sound. *E* is then not called upon to make any readjustment of the instrument; though it is safer to turn the cage, at random, before *O*'s eyes are opened.]

PRELIMINARIES. — *E* must assure himself that *O* is properly placed, *i.e.*, that the line joining his two ears coincides with a portion of the diameter of the wire semicircles, and that the centre of this line coincides with their centre. Chair and head-clip are to be adjusted, until the right position is found; and notes are to be taken, and marks made, so that the position can easily be refound in later experiments.

E should also make a series of tests in order to determine the

limits of accuracy of the instrument. Can the semicircles be set accurately to the scale marks, *i.e.*, to $1/100$ of a revolution? Can they be set to 0.5 of a scale division, *i.e.*, to $1/200$? Can they be set still more accurately?

Finally, a system of notation must be arranged. Suppose that the cage is set at 16-0, and that the localisation is 12-95. This means that *O* has fallen short of the true position of the receiver by 4 divisions in the vertical, and by 5 divisions (for we read from the median line rightwards) in the horizontal plane. Errors of this sort, errors which indicate that *O* has not gone far enough, are termed *negative* errors. Suppose, again, that the cage is set at 20-35, and that the localisation is 23-40. This means that *O* has overstepped, passed beyond, the true position of the receiver, in both planes. His errors are *positive*. The record 16-35, 12-40 would thus indicate a negative error in the vertical, and a positive in the horizontal plane.

EXPERIMENT (1). *Procedure with Partial Knowledge.* — It is arranged beforehand, between *E* and *O*, that the stimulus shall be given at definite points upon the surface of the sound sphere. The points will be taken in haphazard order; but no point will be taken which is not in the prearranged list. Thus the points selected might be: 0, 5, 15, 25, 35 in the vertical plane, and 0, 10, 20, 30, 40, 50, 60, 70, 80, 90 in the horizontal plane. *O* would then know that combinations like 25-70, 35-20, 15-90, etc., might occur in irregular order; but he would be sure that no other combinations than those in the list were to be used.

O seats himself in the chair, and *E* adjusts the head-rest. *O* closes his eyes. *E*, moving as noiselessly as possible, sets the semicircles for the required test. He then closes the key, and gives the ready signal by touching *O* lightly with a rod. The touch must always be given at the same part of the body (*e.g.*, on the chest), in order that it may not itself assist towards localisation. Two sec. after the touch, *E* opens the key, and the receiver clicks. *O* localises it, by words, rod or cardboard semicircles, and gives what introspective report he can. *E* notes the observation, and writes down the introspection. He then prepares for a second test; and so on. The work is fatiguing, and

the full series of tests should therefore be broken up into series of 10, 10, 10 and 11, with pauses for rest between these minor series.

The set of 41 tests should, if time permit, be repeated three times, once with each of the three localisation methods. The errors for the various settings, and their mean variations, are calculated, in this and in the following experiments, according to rules given by the Instructor.

EXPERIMENT (2). *Procedure without Knowledge.* — *E* makes out a Table of 50 positions, taken in random order from all parts of the sound sphere. *O* is told that the click may come from any direction; he is to localise it as before.

After consultation with the Instructor, another Table of 50 tests is made out, and the experiment repeated.

EXPERIMENT (3). *Localisation with One Ear.* — *O* stops his right ear with a plug of cotton wool and wax. The experiment is then performed as in (2), first series.

EXPERIMENT (4). — This, too, is a repetition of the first half of exp. (2), except that *O* does not attempt to localise the click exactly, in visual, tactual or verbal terms, but proceeds at once to analyse his mode of judgment. If, *e.g.*, the judgment is "Low, back," he does not attempt to translate this into 40-50, or whatever the numbers may be, but asks himself at once: "How do I know that it is low and back?" And so on.

RESULTS. — *E* has his rough Tables, his Tables of (positive and negative) errors for the different settings, with their mean variations, and *O*'s introspections. The following Questions arise.

E (1) Give a general summary of the results of exps. (1) and (2). Can you derive from them any laws or uniformities of sound localisation?

E (2) What is the rule of localisation in exp. (3)? Can you explain it?

O and *E* (3) Write out, from the introspective records and from memory, a concise statement of the mechanics of sound localisation in your special case. How—in what terms—do you localise the clicks?

O and *E* (4) What are the principal defects of the sound cage? Can you suggest improvements?

O and *E* (5) What portions of the sound sphere should you select for most detailed experiment if you were now planning an investigation into the mechanism of judgment in sound localisation? Give reasons.

O and *E* (6) Give a theory of sound localisation. Suggest further experiments, by which the theory that you adopt may be tested.

O and *E* (7) Compare the spatial functions of touch, sight and hearing. Can one localise two differently placed sounds at the same time? Suppose that three matches are struck at different parts of the room; can you hear the sound triangle?

CHAPTER XI

TACTUAL SPACE PERCEPTION

EXPERIMENT XXXIII

§ 48. **Localisation of a Single Point upon the Skin.**—This experiment gives a rough answer to two questions. The first is: How near can *O* come, with closed eyes, to finding a spot upon the skin that has just been touched by *E*? In other words: How accurately can the skin localise an impression for itself, without the help of vision? And the second is: How—in what conscious terms—does *O* localise the impression?

MATERIALS.—Two pencils, each brought to a smooth, blunt point. A mm. paper scale. Compasses. India ink and brush. Chalk.

PRELIMINARIES.—*O* sits sidewise at a low table, his bared left fore-arm resting along its edge, volar side upwards. Care must be taken that the rolled-up sleeves do not bind the upper arm too tightly. His eyes are closed, or turned away, throughout the experiment. His attitude in sitting (crossing of knees, etc.) must remain as constant as possible. His right hand is placed, before each experiment, in the same position: *e.g.*, on the right knee.

E draws a transverse line in India ink across the exposed arm, at a distance of 6–8 cm. above the carpal folds. The space thus marked out is the area of experimentation. Its boundary-lines are denoted by the letters *R* (radial), *U* (ulnar), *P* (peripheral, towards the wrist) and *C* (central, towards the elbow). A life-size sketch-map of the area is made, the chief landmarks (lines of hair, cords, wrinkles) being drawn in free-hand. A blank Table is also prepared: three columns are necessary, for the number of the experiment, the amount of error in mm., and the direction of error (*P, C, R, U, PU, PR, CU, CR*). Not less than

25 experiments should be taken; 50 are enough. The area should be worked over as evenly as possible, so that there are as many localisations made at one part of it as at another.

It may be necessary to interrupt the sitting, owing to fatigue. Hence chalk marks should be made on the table, to show the exact position of the arm, and chalk rings should be drawn round the chair-legs, on the floor, to prevent change in the attitude of *O* when he returns to work.

EXPERIMENT. — *E* places a pencil in *O*'s right hand, and gives the signal. Keeping well away from *O*, so as to avoid chance contacts with the bared arm, he sets his own pencil firmly down upon some point of the skin surface. The pencil must indent, but not bruise the skin. It is held in place for about 1 sec. On its removal, *O* moves his right hand across to the table, and sets his pencil lightly down upon the skin, as close as possible to the point of previous stimulation. If he does not strike this to his satisfaction, he may move the pencil lightly along the surface, till he comes to the right point: then he presses firmly. He must not lift his pencil from the skin after he has once touched.

E now takes *O*'s pencil from him, and the localising hand goes back to its former position. *E* measures the amount of error (the distance between point of stimulation and point of localisation) by setting the compass points upon the skin, in the two little pits left by the pencil pressures, and then applying the compasses to the mm. scale. (1) He enters the amount of error and the direction of error in his blank Table. (2) He makes a dot on the map at the point of stimulation, measures off the amount of error in the right direction, and draws an arrow from the dot to the point of localisation. Just under the dot he puts a figure,—the number of the experiment in the series. When this is done, or (in part) while it is doing, he may receive *O*'s report, and put questions to him. —

The pencils are exchanged from experiment to experiment. *O* is, therefore, now given *E*'s pencil; the signal follows; and a new experiment is made.

RESULTS. — At the end of the sitting, *E* has a Table which shows the size of the errors in the separate experiments, and the

directions of these errors ; he has also a map, showing the points which *O* was required to localise, the order in which these points were stimulated, and the amount and direction of the errors made. Table and map thus supplement each other. He has, further, the record of *O*'s introspections. The following Questions arise.

O (1) How do you know, in each case, that you have struck the right point ?

E (2) Break up the experiments into short series, say, of 10 each. Can you trace, in the size of the errors, any effect of practice ?

E (3) Are the errors through the whole list nearly enough alike to allow you to average them, and speak of 'an average error' of localisation for this part of the body ? Or do the errors vary very considerably from part to part of the stimulated surface ? Explain your results.

E (4) Are there any constant tendencies in the directions of the errors ? If there are, explain them.

O and *E* (5) What are the chief defects of the method ?

O and *E* (6) What variations of the experiment can you suggest ? Why do you recommend them ?

EXPERIMENT XXXIV

§ 49. **Localisation upon the Skin : Discrimination of Two Points.** — This experiment answers the questions : How far apart upon the skin must two impressions lie, if they are to be separately perceived, *i.e.*, localised at different places ? And : What are the characteristics of the localising consciousness ?

MATERIALS. — A pair of compasses, tipped with rounded points of hard rubber. A mm. paper scale. Chalk.

PRELIMINARIES. — *O* sits as in Exp. XXXIII. Determinations are to be made upon the longitudinal axis of the arm, beginning from a point lying about 4 cm. above the carpal folds, and about midway between the middle line and the *U* border of the arm.

A few trials are taken at haphazard, to determine roughly the limits within which the experimental series will fall. If you find,

e.g., that with a separation of 30 mm. the points are clearly perceived as two, whereas with a separation of 10 mm. only one point is perceived, you can confine your experimental series within the limits 30 and 10 mm., and save yourself trouble and *O* fatigue. These first trials and their results are to be entered in your note-book.

The points are to be set down as in Exp. XXXIII., and to be held on the skin for 1.5 to 2 sec. They must give equal pressures, and be set down with perfect simultaneity. Other preliminaries as before. No map is needed.

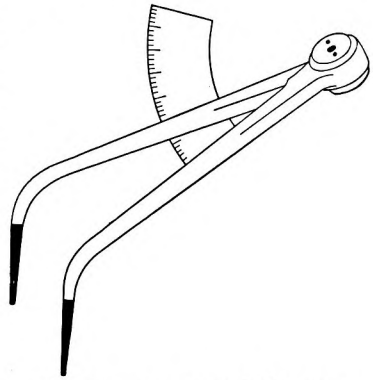

FIG. 56.—Simple æsthesiometer
Chicago Lab. Supply Co., \$3.00.

EXPERIMENT.—Two series of experiments are to be performed, and their results averaged. In the first series, *E* starts out with a separation of the compass points which gives two clear perceptions, and gradually reduces this separation in successive experiments until the two impressions are perceived as one only. In the second he starts with a separation which is too small to give rise to two perceptions, and gradually increases it until two points are clearly perceived. The steps are to be made equal in both series: *E* descends by, say, 2 mm. at a time in the one, and ascends by, say, 2 mm. at a time in the other. *O* is to be told the direction of work, — told, *i.e.*, that a regularly ascending series or a regularly descending series is coming; he is not to know the actual separation of the points with which either series begins.

In a descending series (two towards one), *O* will constantly be expecting the two perceptions to merge into a single perception. Hence he will say “One!” too soon; sooner than he would if he were absolutely impartial. In an ascending series (one towards two), on the other hand, he will be expecting the emergence of two perceptions from the original single perception. Hence he will say “Two!” too soon. By averaging the results of both series, therefore, we eliminate a ‘variable error’ which is involved in the method, the *error of expectation*.

E gives the signal, and sets down the widely separated compass points. *O*'s perception of 'two points' is recorded in the Table, opposite the figures which give the number of the experiment and the separation of the points in mm. *E* now reduces the distance by 2 mm. (or whatever the chosen amount may be), gives a second signal, and takes a second experiment. In order to avoid fatigue of the skin, the positions of the points within the original distance should be varied: thus, if 30 mm. has been given, and 28 mm. follows, the 28 mm. may fall within the 30, or the *P* points may overlap in both cases, or the *C* points may overlap. Take these possibilities irregularly: do not travel out of the line in the lateral directions. — The series is continued until three or four impressions have been perceived only as a single point. The reverse series is then begun, after warning to *O*. It starts from a separation of the points which is somewhat less than that which they had in the last experiment of the first series, and is continued until three or four impressions have been clearly perceived as impressions of two points.

No experiment must on any account be repeated (see p. xiv). If a mistake occur, whether on the part of *O* or of *E*, note the mistake carefully, but go straight on with the series. *E* must record *O*'s separate introspections, paying especial attention to the perceptions which arise in the region of change (when the two are merging into one, and the one splitting into two). *O*'s statements are to be made as soon as the compass points have left the arm; he should not hesitate, or pause to reflect and weigh probabilities. The immediate perception is the mental process to be observed.

RESULTS.—*E* has a Table, which should take the form of the diagram. The direction of the double arrow denotes that the experiments were made upon the longitudinal axis of the arm; that which points downwards denotes a descending, the other an ascending series. These series overlap, for a certain portion of their length. Since the point of change falls too high in \downarrow , and too low in \uparrow ,—coming too soon in each case,—the line that connects the two will have the direction of the dotted line of the diagram. The position of this line, then, is an indication of the presence of the error of expectation.

EXPERIMENT XXXIV

Date,-----

E.-----

O.-----

Condition,-----

VOLAR SURFACE OF LEFT ARM: ↑

Exp.	Mm. ↓	Jdgt.	Jdgt.	Mm. ↑	Exp.
1	x	2	—	—	10
2	$x-2$	2	—	—	9
3	$x-4$	2	—	—	8
4	$x-6$	1	—	—	7
5	$x-8$	1	2	$x-8$	6
6	$x-10$	1	2	$x-10$	5
7	—	—	2	$x-12$	4
8	—	—	1	$x-14$	3
9	—	—	1	$x-16$	2
10	—	—	1	$x-18$	1

SCHEME OF TABLE.

The point of change may be quite easy to determine. *O* may say 'two' in one experiment, and 'one' in the next following, or *vice versa*. More probably, there will be a region of doubt and uncertainty, rather than an abrupt change of perception. The central point of the two regions of change must then be carefully estimated, before the dotted line is drawn. The average of the distances which are finally chosen to stand at the two ends of the line is the distance required, — the least separation that the compass points must have if they are to be separately perceived. The following Questions now arise.

O (1) Were you conscious of a definite expectation? Of any tendency to correct it?

O (2) Does your introspection tell you of any factors that might work against expectation?

E (3) The portions of the ↓ and ↑ series that do not overlap should be as nearly as possible of equal length. Why?

E (4) Perhaps the dotted line has not the position indicated in the Figure, but lies horizontally, or even inclines in the oppo-

site direction. Account for this in the light of *O*'s introspections and of your own arrangement of the series.

E (5) If, at the conclusion of the sitting, you gave the compass points the separation that you have calculated to be the least distance required for two perceptions, and then set them down once upon *O*'s arm, should you expect him to perceive one point or two? Why?

O and *E* (6) How do you account for the peculiar character of *O*'s perceptions in the region of change?

O and *E* (7) What variation or modification of the method can you suggest as likely to prove valuable for further work?

E and *O* (8) What further experiments are suggested by the results of Exp. XII.?

E and *O* (9) How, in general, would practice affect the result of this experiment? How might its effects show themselves in your own work?

E and *O* (10) Why are the compasses tipped as they are?

E and *O* (11) Why were you directed to begin work with a ↓ series, rather than with an ↑ series?

EXPERIMENT XXXV

§ 50. **Localisation upon the Skin: Stimulation of Parts whose Relative Position may be Changed.**— This experiment answers the question: How is localisation affected by change in the normal position of two stimulated surfaces? In Exp. XXXIV. *O* was called upon to localise two points within the same area of the skin; he is now called upon to localise two impressions which lie in two different areas. What happens when the normal relation of these areas to each other is altered?

MATERIALS.— Pencil or piece of whalebone. Compasses, as in Exp. XXXIV. A mm. paper scale. Chalk. Indelible ink. Red and green paints or inks. Architects' paper.

PRELIMINARIES.— First of all, perform what is known as 'Aristotle's experiment.' *O* lays out his left hand, volar side up, on the table, and closes his eyes. *E* crosses the middle finger of the hand under the third finger, and places in the fork of the crossed fingers some small object of smooth surface, which

rests equally upon the two phalanges. A pencil will do; a piece of whalebone, about 3 mm. broad, laid flatwise, is better. *O* refers the two perceptions to two objects, *i.e.*, thinks that two distinct objects are pressing upon the two finger-tips. — If this result does not follow on the first trial, the reason is that *O* is visualising, and that the visual images of the crossed fingers and of the single object lying upon them are strong enough to counteract the evidence handed in by the finger-tips. *E* must then make a short series of experiments, in some of which a single stimulus is employed, while in others the fingers are really pressed by two different things. The thin ends of the limbs of the compasses, spread apart, may be laid across the fingers to give the two separate impressions, and the thick part of the apposed limbs may replace the pencil or whalebone. *O* is told that sometimes one, and sometimes two objects will be employed; but does not know which form of stimulus will be used in any given experiment. He cannot, therefore, bring any definite visual expectation to bear upon his introspections. — Do not proceed with the exercise until the visualisation error has been overcome.

For the following experiments, *O* sits squarely to the table, and stretches out his left arm in the sagittal direction, volar side up. His eyes are closed. *E* sits at the opposite side of the table, and applies the compass points to the terminal phalanges of *O*'s second and third (middle and ring) fingers. The crossing of the former under the latter, when crossing is required, is always done by *E*. It is well to uncross the fingers, and to let *O* move his hand freely, whenever there is any indication of fatigue. Before the experiments begin, *E* should make dots with ink upon both fingers at the point of crossing, so that the degree of crossing may be kept constant throughout. Chalk lines are drawn round the legs of *O*'s chair, and also on the table round the arm and hand. The Tables for all the experiments are prepared beforehand.

EXPERIMENT (1). *Discrimination Experiments.* — Leave the fingers in their normal position. Apply the compasses transversely, setting one point on each finger. Use three separation distances: *e.g.*, 4, 12, 20 mm. Compare each of these with the

two others, experimenting in irregular order. Thus: after the signal, set down the compass points at the 4 mm. separation; hold them on the skin for 1 or 1.5 sec.; then remove the compasses, and change the distance to 20 mm.; after 1.5 to 2 sec., set them down at the 20 mm. separation; hold on the skin for 1 or 1.5 sec.; on removal, *O* will say 'larger' or, perhaps, 'clearly larger,' meaning that the 20 mm. separation seemed in perception to be clearly greater than the 4 mm. The giving of these two impressions constitutes a single experiment: thus the next experiment may consist in a comparison of the 12 mm., given first, with the 4 mm.; the third, in a comparison of the 20, given first, with the 12, and so on. Perform the required 6 experiments twice over (24 impressions), entering each result in a Table. — Now cross the fingers, and make another series of 12 experiments, with the same separations, in a different order. Record as before. — Compare the results of the two series.

(2) *Distance experiments.* — Prepare a blank Table, showing the number of each experiment. Use the same three separations. With the fingers in their normal position, set the compasses down on the two surfaces 9 times (3 for each separation), in irregular order. Enter the amount of separation, opposite the number of the experiment, in the Table. *O* has a pencil in his right hand, and, after each impression, opens his eyes and draws on a sheet of paper a line which represents the apparent distance between the stimulus points. As these lines are drawn they must be numbered by *E*, and then immediately covered (*e.g.*, by a book laid over the paper), in order to avoid suggestion from one experiment to another. — Perform the same 9 experiments, in a different order, with the fingers crossed. Compare the two sets of results (Tables and papers of lines); and compare, farther, the apparent separation in the two series of experiments with the real distance between the compass points.

(3) *Localisation experiments.* — *E* prepares beforehand, upon architects' paper, a set of outline sketches of *O*'s second and third fingers. Nine of them show the fingers in the normal, and nine in the crossed position, volar side upwards. He also prepares a blank Table of numbered experiments. The compass points are given a separation of 15 or 20 mm. *E* makes ink

dots on *O*'s fingers at the spots upon which the points lie (in the normal position of the hand) when pressed down in the transverse (*R-U*), the *RC-UP* and the *UC-RP* directions. The middle pair of dots is marked in black, and the diagonal pairs are marked in red and green respectively. *O* must not see these marks. — With the fingers in the normal position, nine experiments are made, in irregular order; *i.e.*, each direction is given three times. At the close of each experiment, after the removal of the stimulus, *O* marks upon one of the first set of sketch-maps the points at which he localises the stimulation. This map is then handed to *E*, who numbers it in accordance with his Table, and returns a blank map to *O*, for the following experiment. At the close of the series, *E* marks on the maps, in a different-coloured ink, the real points of stimulation. — Perform the same experiments (*i.e.*, give impressions at the marked points) in a different order, with the fingers in the crossed position. *O* and *E* record as before, upon the second set of maps. — Compare the results (Tables and marked maps) of the two series of experiments.

RESULTS. — At the conclusion of the experiment, *E* has before him his Tables, sets of drawn lines, and sets of maps. He must now formulate (1) the result of Aristotle's experiment; (2) the statement which sums up the results of the two series of discrimination experiments; (3) a similar statement for the two series of distance experiments; (4) the relation of the estimated distances, in the normal and crossed positions of the fingers, to the actual, measured distances; and (5) the statement which sums up the results of the two localisation series. These five results are to be expressed as concisely as possible, and the summary is to be written in the note-book after the Tables, lines and maps, which show the experimental facts in detail. The following Questions arise.

O (1) Were you aware of any hesitancy in giving the results of your introspection, or were you always sure of what you were reporting?

E (2) Can you suggest any general explanation which shall account for all five of the results obtained? Are the results those which you expected to get? Why, or why not?

E (3) Why were you directed to work with the middle and ring fingers, rather than with the fore and middle fingers? Why did you turn the second under the third, and not *vice versa*?

E (4) What would be the result, in the localisation experiments, if *O* had extended his arm *dorsal* side upwards, with the fingers projecting over a pile of books, and you had crossed the second *over* the third finger, and stimulated the phalanges by pressing with the compass points from below upwards?—Try a few experiments (taking care that *O* does not move the projecting fingers), and explain the results.

E (5) How do you account for the results of *O*'s estimation of the distances between the compass points, in the distance experiments?

O and *E* (6) Can you suggest any similar experiments to be made at other parts of the body? Can you predict their results? Try them, and see if the predictions are verified.

O and *E* (7) What precisely is meant by the term 'suggestion'? What mental processes does the word cover?

CHAPTER XII

IDEATIONAL TYPE AND THE ASSOCIATION OF IDEAS

EXPERIMENT XXXVI

§ 51. **Ideational Types.** — Our own mind is so much a matter of course to us, and we are so ready to ‘judge other people by ourselves,’ that the *differences* between mind and mind are likely to escape notice. We know that so-and-so is ‘imaginative,’ that so-and-so has ‘a tremendous memory,’ and that so-and-so ‘seems to take it all in, when we can’t make head or tail of it’; and we sometimes make, in the course of conversation, a surprised remark about these differences. Nevertheless, we soon slip back into our self-complacency, into the idea that our own mind is the typical human mind.

This error has, of course, a good deal of truth in it. If minds were not fundamentally alike, there could not be the intercourse in the world that there actually is. There could be no high development of commerce, or literature, or science; no settled condition of society. Our mistake is confirmed, then, on the practical side, by the constant observation that one man *is* like another, that the one can treat the other as if he were a second self. But the mistake is also strengthened by the science of mind itself. It is the uniformities of mind that psychology emphasises. We take it for granted, after a few preliminary tests for colour blindness and what not, that the workers in a psychological laboratory have all a like outfit of sensations and feelings, a similar capacity of attention, and so on. The elementary processes and the basal functions of mind are the same in all ‘normal’ individuals.

Yet our first idea is erroneous. Though the elementary processes of every normal mind are the same, yet the parts played by the various groups of processes differ very greatly in different

consciousnesses. And though the basal functions of all normal minds are the same, yet the mechanism of these functions differs very greatly from mind to mind. One man, we say, is 'eye minded,' another is 'ear minded.' The phrases do not mean that the one man has more visual and fewer auditory sensations than the other, and *vice versa*; it means (*a*) that in the one case the average consciousness is composed for the most part of visual, in the other of auditory material; and (*b*) that in the one case the great functions of attending, willing, acting, remembering, imagining, are set going by visual cues and discharged in visual terms, while in the other the vehicle of these same functions is auditory mind-stuff.

In the present experiment, we are to change our standpoint, and examine into the characteristic differences of the average mind. The results cannot be foreseen. *E* may find that the *O* with whom he has been working is of like constitution with himself, thinking as he thinks and speaking as he speaks. On the other hand, he may find that though the trains of ideas in both minds "shoot to the same conclusion," so that "the thinkers have had substantially the same thought," yet the "scenery" of the one mind differs astonishingly from the scenery of the other (James).

Let us see what the possibilities are; and let us take the universal function of *memory* as our point of departure. How may one remember?

One may remember an event (*a*) in terms of sight. The purely eye-minded man would recognise persons, things and places by their look, and would recall events as a panorama of views. Or one may remember (*b*) in terms of hearing. The purely ear-minded man would recognise persons, things and places by the sounds connected with them, and would recall events as a succession of sounds. Plainly, his 'reading' of a situation would be very different from that of his eye-minded friend, and the available ideas of his memory very different from the ideas of the other. One may remember (*c*) in terms of touch. The tactual or motor type of mind recognises and recalls in terms of strains and pressures, the sensations set up

by movements and attitudes. One may remember (*d*) in terms of organic sensations. The organic type of mind is emotional; when it recognises and recalls, it revives the organic accompaniments of first (or previous) acquaintance, the quivers and chokings and flutterings and sinkings that form the proper basis of the sense-feelings. One may remember (*e*) in terms of taste and smell. Images from these sense-departments seem, however, to be less common than the rest. And lastly, one may — as, probably, everybody does — remember (*f*) in mixed terms: some one kind of image predominating, while other kinds form a ‘halo’ or ‘fringe’ about the nuclear complex.

Consider, again, the universal function of *speech*. One may recall words (conversation, statements in the literature of one’s science, poetry, lectures) in terms (*a*) of the written or printed symbols. The visual-verbal mind reads from a memory manuscript or printed page, lying open before the mind’s eye. Or one may remember words (*b*) in terms of their sound. One may remember them (*c*) in terms of their ‘feel’ in the throat, or perhaps of the ‘feel’ of the hand that writes them. And, of course, one may remember them (*d*) in a mixed fashion. More than this: when one speaks, — answers or asks a question, delivers a lecture, recites a lesson, — the words are released or touched off by a sense cue derived from one or more of these sources. The visual-verbal mind sees, the auditory-verbal hears, the tactual-verbal ‘feels,’ what words are coming.

Verbal ideas play a very important part in the educated mind. They offer a common language, into which all other ideas and perceptions may be translated; they furnish a common denominator, to which all the rest may be reduced. Hence it is not surprising that some consciousnesses should be almost, if not entirely, verbal, and that we have to distinguish verbal sub-types alongside of our main ideational types.

The method that has been most largely employed for the determination of ideational type is that of the *questionary*. The questionary or ‘questionnaire’ is a series of questions bearing upon the matter to be investigated, and submitted to a large number of persons for introspective answer. It is assumed that,

although the answers returned by any given person may be of little psychological value, yet the intercomparison of a long list of such answers by a trained psychologist will yield results of real scientific import.

Question (1). — What are the characteristics of a good questionnaire? In what fields of psychology does the method promise to be of value?

Questionary upon Ideational Type

Read the whole questionnaire twice through before you begin to write your answers.

1. Think of a bunch of white rose-buds, lying among fern leaves in a florist's box.

(a) Are the colours—the creamy white, the green, the shiny white—quite distinct and natural?

(b) Do you see the flowers in a good light? Is the image as bright as the objects would be if they lay on the table before you?

(c) Are the flowers and leaves and box well-defined and clear-cut? Can you see the whole group of objects together, or is one part distinctly outlined while the others are blurred?

(d) Can you call up the scent of the rose-buds? Of the moist ferns? Of the damp paste-board?

(e) Can you feel the softness of the rose petals? The roughness of the ferns? The stiffness of the box?

(f) Can you feel the coldness of the buds as you lay them against your cheek?

(g) Can you feel the prick of a thorn? Can you see the drop of blood welling-out upon your finger? Can you feel the smart and soreness of the wound?

(h) Can you call up the taste of candied rose leaves? Of candied violets? Salt? Sugar? Lemon juice? Quinine?

2. Think of some person who is well known to you, but whom you have not seen for some little time.

(a) Can you see the features distinctly? The outline of the figure? The colours of the clothes?

(b) Can you hear the person's voice? Can you recognise your friends by their voices? Can you call up the note of a musical instrument in its appropriate clang-tint: piano, harp, organ, bassoon, flute, trumpet? Can you hear, in imagination, a note that is too high for you to sing? Think of the playing of an orchestra. Can you hear two different instruments playing together? More than two? Do the tones ring out in their natural loudness? Do they come to you from their natural places in the orchestra?

(c) Can you hear, in memory, the beat of rain against the window panes; the crack of a whip; a church bell; the hum of bees; the clinking of teaspoons in their saucers; the slam of a door?

(d) Can you see the person in familiar surroundings? Can you see more of these surroundings (*e.g.*, a room) than could be taken in by any single glance of the eyes? Can you mentally see more than three faces of a die, or more than one hemisphere of a globe, at the same instant of time?

(e) Do you possess accurate mental pictures of places that you have visited? Do you see the scenes and incidents described in novels and books of travel?

(f) Are numerals, dates, particular words or phrases, invariably associated in your mind with peculiar mental imagery (diagrams, colours)? Are certain sounds always connected with certain colours? Have you any other constant associations from different sense-departments? Have you a special gift or liking for mental arithmetic or mechanics? Can you lay a plane through a cube in such a way that the exposed surface shall be a regular hexagon? Through an octahedron? Have you ever played chess blindfold? Explain fully how far your procedure in these cases depends on the use of visual images.

3. Think of the national anthem.

(a) Can you see the words printed? Can you hear yourself say or sing them? Can you hear a company singing them? Can you feel yourself forming the words in your throat, and with your lips and tongue? Can you hear the organ playing the air?

(b) Do you recall music easily? Do you 'make up tunes in your head' when you are thinking steadily or in reverie? Does imagined music take any considerable part in your mental life: *i.e.*, do airs and motives and snatches of music play or sing themselves to you during the various occupations of the day? Have you an 'absolute' memory for music: *i.e.*, can you identify a note that is struck upon the piano keyboard, or tell the pitch of a creaking door?

(c) Partly open your mouth, and think of words that contain labials or dentals: 'bubble,' 'toddle,' 'putty,' 'thumping.' Is the word-image distinct? Can you think of a number of soldiers marching, without there being any sympathetic movement or movement-feel in your own legs? Think of getting up from your seat to close the door. Can you feel all the movements? As intensively as if they were really made?

(d) Are you stirred and moved as you think of the words or music of the anthem? Are you affected in this way at the theatre, or when reading novels? Do you choke and cry (or feel like crying) as you read, *e.g.*, of Colonel Newcome's death? When you think of your childish terrors, or of your childhood's injustices, do you feel over again the fear and resentment?

(e) If you see an accident — the crushing of a limb or the catching of a finger in the door — do you yourself feel the blow and the bruise? Does the sight make you shiver, give you 'goose flesh'? Do you pant or hold your breath as you watch a difficult feat of climbing or trapeze-work? Can you, in

general, call up organic sensations : hunger, thirst, fatigue, feverishness, drowsiness, the stuffiness of a bad cold?

4. Arrange the following 20 experiences in groups, according to the clearness, vividness and distinctness with which you can remember or imagine them.

(a) A gloomy, clouded sky ; a sheet of yellow paper ; a black circle on a white ground.

(b) The feel of velvet ; of dough ; of a crisp dead leaf.

(c) The smell of tar ; of a fur coat ; of an oil-lamp just blown out.

(d) The taste of chocolate ; of olives ; of pastry.

(e) The warmth of a hot-water bag at your feet ; the cold of a piercing wind that cuts through your clothing.

(f) Singing in the ear ; the buzz of an induction-coil vibrator ; the preliminary *a*¹ of the violin.

(g) Nausea ; tooth-ache ; pins and needles.

5. Give any supplementary information that occurs to you on the topics of this questionnaire. Do you recollect what your powers of visualising, etc., were in childhood? Have they varied much within your recollection?—What difference do you find between a very vivid mental picture called up in the dark, and a real scene? Have you ever mistaken a mental image for a reality when in health and wide awake?—Are the characteristics of your mental imagery repeated in the other members of your family?—Have you a good command of your images? Etc., etc.

RESULTS.—Enter your own answers in your note-book, and hand the original sheet to the Instructor. He will presently inform you of your position on the scale of imagery in the different sense-departments. Consult with him as to the advisability of practising one or other of your partial memories. If possible, secure the answers of an *O* whose 'type' is radically different from your own, and enter these too in your note-book.

QUESTIONS.—(2) Can you devise any experimental method for the determination of ideational type? If you can, ask the Instructor whether it is practicable. Work with the questionnaire should always be supplemented by work with some experimental method.

(3) Is the distinction of 'types' applicable to other mental processes than ideas?

EXPERIMENT XXXVII

§ 52. **The Association of Ideas.**—It is one of the fundamental laws of our mental life that all the connections set up between sensations, by their welding together into perceptions and ideas, tend to persist, even when the original conditions of connection

are no longer fulfilled. This law we term, in conformity with historical usage, the law of the association of ideas. The phrase is, however, to be accepted with great caution, and with two qualifications. In the first place, it is not ideas that associate, but the elementary processes of which the ideas are composed; and, secondly, the connection is not an 'association,' if we mean by association a mere juxtaposition, an unchanged togetherness. It would be more correct to speak, in non-committal language, of the law of temporal and spatial connection of the conscious elements. On its physiological side, the law then reduces to a law of habit. "When two elementary brain-processes have been active together or in immediate succession, one of them, on re-occurring, tends to propagate its excitement into the other" (James).

Both of the above formulæ employ the word 'tend.' The connections 'tend' to persist; the brain activities 'tend' to discharge. The question arises: under what conditions is the tendency realised? Suppose that the complex ab is given. The part-process b has been in connection with $c, d, e, \dots z$. Will the association-consciousness have the form abc , or abd , or abz ? This is a question which experimental psychology is called upon to answer. It is, also, a question to which a fairly complete answer can be returned.

The conditions under which a given connection — abc or abz — is realised may be summed up as follows.

A. If the consciousness of the moment is an attentive consciousness, the appearance of c or z depends upon

- (*a*) the *frequency* of connection with b ,
- (*b*) the *recency* of connection,
- (*c*) the relative *vividness* (intensity, extent, etc.) of c and z , and
- (*d*) the relative *position* (primacy) of c and z in a definite series of processes.

B. If the consciousness of the moment is an inattentive consciousness, the appearance of c or z depends upon

- (*e*) the relative power of c and z to attract the attention (see p. 116, above).

All five of these rules are to be subjected to experimental test.

A. I. SUCCESSIVE METHOD. Visual Stimuli

MATERIALS. — Memory Apparatus. [This apparatus consists of a black upright screen, 82 by 21 cm., at the centre of which is an oblong window, 15 cm. broad and 3 cm. high. A flap of japanned tin, hinged below, can be turned up to cover the window. Behind the window slides a horizontal strip of japanned tin, having two openings, of 6 by 2.5 and 2 by 2.5 cm. respectively.

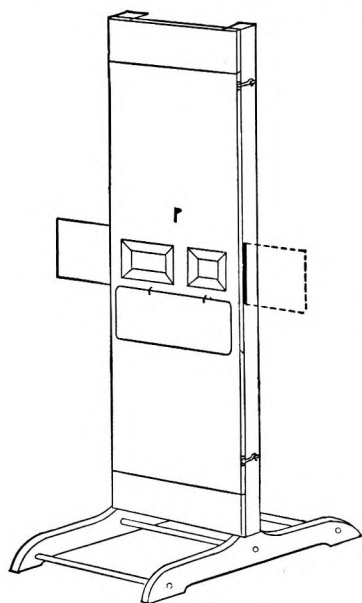

FIG. 57

The card holder, 40 by 18 cm., runs in grooves behind the screen. To its back is nailed a strip of gutta percha, cut out step-fashion in such a way that each turn of a lever to right or left drops the card holder through 2.5 cm. The card is covered with letters, numerals, bands of colour, etc. It is possible, if the card holder starts at its full height, to expose 14 successive stimuli behind each of the openings in the horizontal strip of tin.]

Stimulus cards. Test cards. [These are prepared by *E* under the Instructor's directions, and are not seen by *O*.] Stopwatch.

EXPERIMENT (1). Frequency.

—The apparatus is set up, in a good light, at a convenient distance from *O*. The horizontal strip is so placed that its larger opening fills the centre of the oblong window. It is well to stand screens of black cardboard to right and left, so that *E* shall be entirely concealed from view. *E* selects a stimulus card, with its corresponding test card, and slides the former into the card holder. The stop-watch lies on the table by his side.

E takes the string of the shutter in his left, and the lever in his right hand. At a "Now!" *O* fixates the centre of the shutter. Some 1.5 sec. later, *E* drops the shutter, and *O* sees a coloured strip in the opening. This remains in sight for 2 sec.

Then, without pause, the card holder is dropped a step, and a number appears. This remains for 2 sec. The shutter is then raised, and nothing is shown for 4 sec. During this interval, *O* should count aloud *a, b, c, d, . . .* Before the 4 sec. are over, *E* has dropped the card holder another step. On the falling of the shutter, a new colour is seen; it remains for 2 sec.; then comes a number for 2 sec.; then the shutter for 4 sec., with the speaking of the alphabet by *O*. We thus have a series of 14 2-sec. exposures, each pair of which is separated by an alphabet-interval of 4 sec.

At the end of the series, *E* slips the lever, draws out the card holder, quickly substitutes the test card for the stimulus card, and replaces the holder. With practice, these operations should not take more than 10 sec.; but 15 or 20 sec. may be allowed, if the Instructor thinks fit. The experiment is then resumed. Each colour is exposed for 4 sec., and there are no intervals. *O* is required to write down, as the colour appears, the number (if there be any) with which it is associated. At the end of the series, *O* adds such introspective remarks as occur to him, noting with especial care cases in which the connection of colour and number corresponded to a preformed association.

At least 20 series should be taken.

EXPERIMENTS (2), (3), (4). — The experiment is performed in the same way, except that 'recency,' 'vividness' and 'primacy cards' are substituted for the 'frequency cards.'

RESULTS. — *E* has the cards, and *O*'s lists of associated numbers. His task is, to estimate the importance of frequency, etc., as conditions of connection.

(1) The first thing to do is to rule out all cases in which a connection between colour and number already existed. If the connection is found at a critical point of the series, — if, *i.e.*, it obtains between the frequent, recent, etc., colour and number, — the whole series is rejected; if it occur at any other point, only the single term of the series need be sacrificed.

(2) *E* must then calculate the relation of actual to possible 'correct associations' in the full 80 series, — critical combinations being omitted. In other words, he answers the question: What proportion of the ordinary combinations, in an experiment

of this kind, is remembered by *O*? The experiment is reduced to a simple test of memory, and a percentage is obtained which serves as a basis of comparison for the special percentages which are now to be worked out.

(3) Four Tables are to be made out, one for each of the sets of 20 series, showing (*a*) the percentage of cases in which both numbers — the critical and the normal — were associated, (*b*) the percentage in which only the normal number was recalled, and (*c*) the percentage in which only the critical number was recalled. Cases in which one digit of the number was correctly associated are termed 'half cases,' and counted as half correct.

The following Questions arise.

E (1) What is the relative importance of the four conditions studied in these experiments?

E and *O* (2) Do you regard these results as generally valid, or as valid only under the special conditions of the experiments?

O (3) You have probably found, in the course of the experiments, combinations of colour and number which were already associated in your mind. Can you account for these preëxisting connections? Are they referrible to any one of the four conditions under investigation?

II. SIMULTANEOUS METHOD. *Visual Stimuli*

EXPERIMENTS (5)–(8). — These experiments are performed in the same manner as the preceding, except that both openings in the horizontal strip fall within the oblong window, that the 12-term simultaneous cards are substituted for the 7-term successive cards, and that the paired stimuli are shown for 3 sec. Ten series are to be taken under each of the four rubrics, and the results worked out as before.

E and *O* Question (4) Can you suggest experiments, similar to exps. (1)–(8), with auditory in place of visual stimuli? Can you propose other modifications of these experiments?

B. The investigation of the conditions summed up under (*e*) is more difficult than that of conditions (*a*) to (*d*). For we cannot secure in *O* a state of 'voluntary inattention,' in order to subject him to attention-compelling stimuli. We can, however,

employ an indirect method to show the extreme importance, for associative supplementing, of what is, in adult life, one of the chief determinants of attention.

MATERIALS. — The apparatus is that of Exp. XXV. (4). The object cards are prepared by *E* as directed by the Instructor.

EXPERIMENT (9). — The apparatus is set up with an exposure sector of 3.6° , and a rate of revolution of 1 per second. *E* pronounces two words, which give a certain 'trend' to *O*'s consciousness, or 'prepare' it for the arousal of a certain class of ideas. As soon as he has heard the words, *O* looks through the tube; sees, first, the accommodation A; and, at the next revolution of the disc, reads the word shown upon the object card. He writes an account of what he has seen.

RESULTS. — *E* has his own record of stimuli, and *O*'s descriptions. The following Questions arise.

E (5) What is the general conclusion to be drawn from this experiment? What is the 'determinant of attention,' referred to above?

O and *E* (6) Can you suggest a similar experiment with auditory stimuli?

O and *E* (7) Is this 'indirect method' adequate to our problem? Criticise it in detail.

C. THE TRAIN OF IDEAS. — In the last experiment we have been dealing with 'associative supplementing,' one of the forms of simultaneous association. The counterpart of associative supplementing, on the successive side, is the 'train of ideas.' A consciousness is set up, and allowed to work itself out, idea following idea along the line of least mental resistance, until the 'stream of thought' runs dry. The train of ideas is historically interesting, as the form of association discussed and illustrated by the older psychologists under the general title 'association of ideas.'

MATERIALS. — Speaking-tube, leading from the dark room to an adjoining room. Stop-watch.

EXPERIMENT (10). — *O* sits comfortably in the dark room, his ear to the speaking-tube. His mood should be as passive and receptive as possible. After a signal (the stroke of an electric bell, or a "Now!" called through the tube), he listens attentively

for *E*'s voice. *E* speaks a sentence, or asks a question, through the tube. The sentence or question must be concrete, pictorial, — one that can hardly be apperceived or answered simply in terms of words. *O* gives free rein to the series of ideas aroused by the stimulus. As situation follows situation in his consciousness, he calls catch-words through the tube: *E* writes these down, and notes the time of their utterance. At the end of the experiment, when the train of ideas is exhausted, *O* goes over the catch-words with *E*, in introspective review, and so reconstructs, as accurately as may be, the whole association consciousness.

The principal points to note in the reconstruction are (*a*) the number and order of the situations (constellations of ideas); (*b*) the quality of consciousness — visual, auditory, etc. — at each situation; (*c*) the affective colouring of each situation; (*d*) the form of connection (association 'by contiguity' or 'by similarity'); (*e*) the richness, fulness, clearness, of the part-consciousnesses (the processes composing a situation or constellation); and (*f*) the points of departure of the various constellations. Under (*e*), for instance, *O* notes the relative expansion or contraction of consciousness, whether it is made up of a single strand or of several interwoven strands; under (*f*), he draws a diagram, showing where the associative train is continuous, *a* giving rise to *b*, *b* to *c*, *c* to *d*, and so on, — and where there is a hark-back to a former situation, *a* giving rise to *b*, *b* to *c*, and then *a* coming into play again as the source of *d*.

RESULTS. — *E* has the full verbal record of *O*'s associations. He has, further, a Table of seven columns, showing respectively the times, situations, qualities, affective concomitants, modes of connection, richness, and points of departure of these associations. Six experiments should be made. The records will present a fair picture of *O*'s consciousness during the 'train of ideas.'

E and *O* Question (8) Define the terms 'association by similarity' and 'association by contiguity.' Give instances. How do you reconcile the existence of two distinct forms of association with the preliminary statements on pp. 200 f. ?

LIST OF MATERIALS

THE following list of the Materials required for this Course does not include the appliances called for by "Questions" and "Cognate Experiments," for which see Part II. Materials here marked "not specified" are fully described in Part II.

If the laboratory already possesses other and less simple forms of the standard pieces recommended in the text, the conduct of the experiment may be modified to suit the Materials. The author has had the possibility of such modification in mind in his description of the experiments.

The Materials cannot be ordered from any single firm, but are all easily procurable.

I. SPECIAL APPLIANCES

- | | |
|--|--|
| Æsthesiometer, 186, 191. | Olfactometer, double, with cylinders (not specified) and spare inhaling tubes, 79, 85. |
| Apparatus for negative after-images, 26 f. | Ophthalmotrope, 135. |
| Arm-rest, 88. | Pain points, 61. |
| Atomiser and ether, 88. | Piano, 34, 47, 177, 178. |
| Automatograph, 95. | Piston-whistle, 47. |
| Bell metronome, 115. | Plethysmograph, 103. |
| Biconvex lens in stand, 64, 67. | Pressure point, 59. |
| Campimeter, 9. | Pseudoscope, 146. |
| Colour mixers, 5, 10, 16, 111. | Quincke's tubes, 34, 40, 44, 47. |
| Electrodes, as specified, 88. | Recording apparatus: kymograph and accessories, Marey tambour with writing point, time marker, 103, 111. |
| Eye-rest, 10. | Rotation apparatus with electric or water motor, 113, 205. |
| Finger dynamometer, 100. | Sonometer, 50. |
| Frame for after-images, 25. | Sound cage, 179. |
| Harmonical or harmonium, 43, 45. | Stereoscope, 139. |
| Harmonicas, as specified, 172. | Stop-watch, 36, 77, 78, 205. |
| Head-rest, 73, 111. | Telephone receiver, 179. |
| Hypodermic syringe, 75. | Temperature cylinders, 54. |
| Induction coil, 88. | Tuning-forks, 34, 35, 36, 38. |
| Key, electric, 88, 179. | Vernier chronoscope, with accessories, 118. |
| Memory apparatus, 202. | |
| Metronome, without bell, 175, 176, 178. | |

II. GENERAL APPLIANCES AND MATERIALS

- Balls, coloured, 147, 148.
 Beakers, 84.
 Bowls for water, 53.
 Bunsen burner, 54.
 Bust, plaster, 148.
- Camel's-hair brushes, 50, 54, 59, 64, 67, 68, 73, 84, 184.
 Caraffe, 65, 67, 68, 100.
 Clamp, wooden, 81.
 Cork, weighted, 54.
 Corks, 40.
 Cotton wool, 64, 68, 71, 72, 77, 78, 182.
- Dishes, small tin, 97.
 Drinking glasses, 65, 67, 68, 100.
- Earthenware pans, 54, 73.
 Elastic cord, 89.
 Eye-shade, 10.
- Felt, 175, 176.
 Felt hammer, 35, 36, 38.
 Flat ruler, 140.
- Glass, coloured, 22.
 Glass Y-tube, 172.
- Half-hoops, of wood, 148.
 Hard-rubber syringes, 100.
- Leclanché cells, 88, 179.
- Match-boxes, 148.
 Medallions, plaster, 148.
 Metronome box, 176.
- Needle and thread, 75, 88.
- Pan or bucket, 65, 67, 68, 71, 100.
 Pasteboard mask, 150.
 Phials, narrow-mouthed, 67.
 Phials, stoppered sample, 72, 77, 84.
 Phials, wide-mouthed, 64.
 Pins, 15, 23, 25, 111.
 Pins, black-headed, 140.
 Pipettes, 68, 84.
- Quills, or short glass tubes, 172.
- Razor, 61.
 Resonance jar, 35, 36.
 Rod, 179.
 Rubber bulb, 111.
 Rubber rings, 143.
 Rubber tubing, 35, 54, 172.
- Scissors, 15, 23, 59, 138, 148, 150.
 Speaking-tube, 205.
 Spirit level, 73.
 Sponge, 73.
 Sponge, fine, on wooden handle, 61.
 Spool or round ruler, 150.
 Standards, with adjustable arms and clamps, 73, 96, 113.
- Tea-cups, 148.
 Teaspoons, 71.
 Thermometer, 57.
 Thread, 138, 147, 149.
 Tin, perforated, 75.
 Tin, sheet, 73.
 Tripod, 57.
 Tube, black, as specified, 113.
- Vessels for heating and mixing water, 57.
- Weights, as specified, 88.
 Whalebone, 190.
 Wire, stiff, 138, 148.
 Wire, white and grey, 149 f.
 Wire-models, geometrical, 148.
 Wires, connecting, 88.
 Wooden blocks, as specified, 34, 150.

III. PAPER, CLOTH, DRAWING MATERIALS, ETC.

- Aniline dyes, red and green, 54, 190; blue and violet, 59; brown, 61.
 Architects' paper, 54, 59, 75, 190.
 Black cloth, 23.
 Black velvet, 15, 22, 23.
 Book with ribbed-cloth binding, 33.
 Card, accommodation, as specified, 113, 205.
 Cardboard, black, 23, 93, 150.

- | | |
|--|--|
| Cardboard, figured squares of, 149. | Note-book, xvi. |
| Cardboard, white, 15, 23, 25, 30, 93, 138,
140, 142 f., 148, 150. | Paint, black oil, 73. |
| Cardboard semicircles, as specified, 179. | Paints, oil, 150. |
| Cards, object, as specified, 113, 205. | Paper, black, 15, 16. |
| Cards, stimulus, not specified, 202, 204. | Paper, white, 16, 22, 148, 150, 162. |
| Cards, test, not specified, 202, 204. | Paper, white tissue, 15. |
| Chalk, 73, 184, 186, 190. | Papers, coloured, 15, 22, 25, 30, 93, 142. |
| Compasses, 23, 150, 184. | Papers, grey, 15, 22, 25, 93, 142. |
| Cross-ruled mm. paper, 61, 93. | Paste, 148, 150. |
| Disc, white, with sector, as specified, 113,
205. | Pencils, differently coloured, 138, 147, 150,
184, 190. |
| Discs, black, white and grey, 5. | Protractor, 5, 10, 16. |
| Discs, coloured, 5, 10, 16, 25. | Puzzle pictures, 110. |
| Discs, Masson's, 111. | |
| Fine cloth for drying skin, 61. | Reading glass, 59, 61. |
| Fixation cross of white card, 147. | Screen, dead-finish black, 147. |
| Fixation point, white, on grey card, 10. | Screens, grey, 5, 10, 16. |
| Indelible ink, 54, 59, 61, 190. | Spectrum chart, 5. |
| India ink, 184. | Stereoscopic slides, not specified, 140. |
| Mm. paper scale, 10, 54, 59, 184, 186, 190. | Thumb tacks, 23. |

IV. SMELL AND TASTE SOLUTIONS, ETC.

- | | |
|--|---|
| Baker's chocolate, 72. | Spirits of camphor, 78. |
| Distilled water, 65, 67, 68, 71, 100. | Taste solutions, as specified, 64, 68; not
specified, 67, 100. |
| Ice, 54, 73. | Tastes, as specified, 71. |
| Oil of cloves, 75. | Tincture of iodine, 78. |
| Paraffin, 73. | Tincture of peppermint, 72. |
| Salt, 54. | Vaseline, 103. |
| Smell solutions, not specified, 77, 78, 84,
97. | Water, warm and cold, 54, 57, 61, 74, 88,
103. |
| Soap, 61. | Wax, 36, 38, 40, 182. |

V. LABORATORY FURNITURE

- | | |
|------------------------------|---|
| Chair, adjustable high, 103. | Table, low, 54, 57, 59, 61, 89, 96, 101, 184,
190. |
| Desk, standing or table, 23. | Table, narrow, 65, 73. |
| Shelves, black, 148. | |

The laboratory should possess some shallow wall-cases, glazed in front, to hold the apparatus when not in use, and at least two revolving-seat, swing-back, padded chairs.

INDEX OF NAMES AND SUBJECTS

- Accommodation, mechanism of, 132.
- Action, psychology of, 118.
- Adaptation, visual, general and local, 22; after-effects of, 23; cutaneous (pressure, warmth and cold), 53 f.
- Æsthesiometer, 187.
- Affection, psychology of, 91 f.; as mental element, 92; experimental investigation of, 92, 95, 100, 103; and attention, 108 f., 110, 116 f.
- After-images, visual, negative, 22; laws of, 23; apparatus for, 27; positive, 28; positive and complementary, 29; binocular, 30.
- Aristotle*, 190.
- Aristotle's experiment, 190; discrimination, 191; distance, 192; localisation, 192.
- Arm movement, involuntary, as index of affection, 95, 97, 98.
- Association, affective value of, 92; illusions of, 164; of ideas, 200; physiology of, 201; conditions of, 201; apparatus for study of, 202.
- Associative supplementing, 205.
- Attention, psychology of, 108 ff.; as state of consciousness, 110; sense-processes in, 116; and affective processes, 116 f.
- Auditory sensation, classes of, 31; stimulus to, 31; nomenclature of, 31 f.; series of qualities, 33.
- Automatograph, 96.
- Beat-tone, lower, 40; upper, 42.
- Beats, 35; pitch of, 37 f.
- Black, sensation of, 4, 143.
- Bolton, T. L.*, 174.
- Brewster, D.*, 130.
- Brightness or neutral colour, 3; brightness value of colours, 13; contrast, 15.
- Campimeter, 9 f.
- Clang, definition of, 33, 49; analysis of, 47.
- Clang-tint, 46.
- Colour, antagonistic, 5 f.
- Colour blindness, 14.
- Colour, complementary, 5 f.
- Colour equations, 6 ff., 13.
- Colour mixture, laws of, 5; apparatus for, 6; binocular, 142 f.
- Colour pyramid, 3.
- Colour sensitivity, distribution of, 9.
- Colour tone, 3; contrast of, 16.
- Combination-tones, 39.
- Compensation of smells, 79.
- Competition, danger of, in psychological work, xiii.
- Contrast, visual, laws of, 15; marginal, 18; in the visual after-image, 25 f.; of taste, 68; of smell, 85.
- Conversion, pseudoscopic, 145.
- Corresponding points, 136.
- Cutaneous localisation, method of single point, 184; discrimination of two points, 186; Aristotle's experiment and variants, 190.
- Cutaneous sensation, 52.
- Definitions, importance of, xvii. f.
- Degrees of tonal fusion, 171.
- Difference-tone, first, 40, 44; second, 40, 42, 45; third, 44 f.
- Direction, illusions of, 160, 162.
- Discs, rules for rotating, 5 f.
- Distance, secondary criteria of, 144, 149.
- Donders' law, 136.
- Double images, 136, 137 f., 140.
- Ears, pitch-difference of the two, 38.
- Elements, the mental, 3, 91.
- Ellis, A. J.*, 33.
- Ellis harmonical, 43, 45.
- Expectation, error of, 187.
- Experiment, psychological, definition of, xiii., xv., 1; duration of, xiv.; record of, xvii.; Du Bois Reymond's, 87; Scheiner's, 133, 137; Aristotle's, 190.

- Experimenter, function of, in the psychological experiment, xiii. f.; xv. f.
 Extent, illusions of, 157, 159.
 Eye, the reduced, of Listing, 130 f.
 Eye movement, binocular, laws of, 133.
- Faculties, psychology of, 108 ff., 115 f.
 Finger dynamometer, 100.
Fourier, J. B. J., 49.
 Frequency, as condition of association, 202, 204.
 Fusion, of smells, 70 f.; of tones, 171; degrees of tonal, 171; apparatus for study of tonal, 172.
- Gustatory sensation, 63; organs of, 63 f.
- Harmonica, 172.
 Harmonium, 43, 45.
Helmholtz, H. L. F. von, 5, 9, 21, 28, 33, 46, 49, 117, 132, 137.
Hering, E., 4, 5, 9, 12, 21, 28, 54.
Hoeffler, A., 117.
- Idea, types of, 195.
 Illusions, geometrical-optical, definition of, 151; psychology of, 151 f., 166; of reversible perspective, 152; variable, of extent, 157; constant, of extent, 159; variable, of direction, 160; constant, of direction, 162; of association, 164; with complication of conditions, 164.
- Impression, method of, for study of affection, 92.
- Individual psychology, 195.
 Inductorium, 88.
 Instructor, appeal to, xv., xvii. f.
 Interference of tonal stimuli, 33 f., 35 ff.
 Intervals, musical, 32, 172.
 Introspection, in psychological work, xiii.; maximal duration of, in an experiment, xiv.; data of, 109.
- James, W.*, 117, 196, 201.
- Külpe, O.*, 117, 151.
 Kymograph, 104.
- Lipps, Th.*, 151 f.
Listing, J. B., 131, 136.
 Listing's law, 136.
Ludwig, C., 71.
- Memory, mechanism of, 196 f.
 Method, not to be varied, xiv., 188; aim of scientific, 2; in colour mixture, 7; of impression and expression, in study of affection, 92, 95, 100, 103; of sound localisation, 180.
- Metronome, 115, 175 f.
Meumann, E., 174.
- Mixture, of colours, 5; of tastes, 63; of smells, 83.
- Motor points of fore-arm, 90.
 Muscular sensation, 88.
- Muscular strength, as index of affection, 100, 101, 102.
- Noise, simple, 31; and tones, 33 f.
 Nonius, theory of, 120.
- Note-book, experimental, xvi. f.
- Observer, function of, in the psychological experiment, xiii. f.; xv. f.
Ohm, G. S., 49.
- Olfactory sensation, 70.
- Olfactometer, 80.
- Ophthalmotrope, 135.
- Oppel, J. J.*, 151.
- Organic sensation, 87.
- Overtones, 49.
- Pain, quality of, 53; organs of, 60; pain point, 61.
- Paired comparisons, method of, 92.
- Partnerships, experimental, xv. f.
- Perception, psychology of, 127 ff.; problem of, 129; relation of, to sensation, 127, 130; of visual space, 130, 137, 144, 151; of fusion degree, 171; of rhythm, 174; of the locality of sound, 178; of tactual space, 184, 186, 190.
- Perspective, illusions of reversible, 152.
- Piano, 34, 47, 177, 178.
- Pitch, of a beating complex, 37 f.; pitch-difference of the two ears, 38; and clang-tint, 46.
- Plethysmograph, 103.
- Pressure, quality of, 53; organs of, 58; pressure point, 59.
- Primacy, as condition of association, 203, 204.
- Pseudoscope, 146.

- Questionary, 197 ff.
- Questions, on colour mixture, 9; on cam-
pimetry, 14; on visual contrast, 21; on
visual after-images, 25, 26, 28, 30; on
auditory sensation, 35; on beats, 37 f.;
on cutaneous sensation, 54; on tem-
perature spots, 56; on areal sensitivity
to warmth and cold, 58; on pressure
spots, 60; on pain spots, 62; on taste
sensitivity, 65; on the taste qualities,
67; on taste contrasts, 69; on the
field of smell, 76; on smell exhaus-
tion, 79; on smell compensations, 83;
on smell mixtures, 84 f.; on smell con-
trasts, 86; on organic sensation, 87 f.;
on muscular sensation, 90; on affec-
tion (method of impression), 94 f.; on
involuntary arm movement, 99; on
dynamometry, 102; on plethysmogra-
phy, 107; on attention in general, 110;
on attention as state of conscious-
ness, 111, 112 f., 115 f.; on the sense
processes in attention, 116; on atten-
tion and affective process, 115 f.; on
action, 118; on the simple reaction,
123, 125; on the reduced eye, 131; on
the formation of the retinal image, 132;
on accommodation, 133; on eye move-
ment, 135 f.; on retinal correspond-
ence, 137; on stereoscopic vision, 139;
140, 143; on pseudoscopic vision, 146,
147, 151; on optical illusions, 166 ff.;
on tonal fusion, 173 f.; on rhythm, 176,
177, 178; on localisation of sound,
182 f.; on cutaneous localisation of
a single point, 186; on æsthesiome-
try, 189 f.; on Aristotle's experiment
and variants, 193 f.; on the ques-
tionary, 198; on ideational type, 200;
on association of ideas, 204, 205,
206.
- Quincke's tubes, 40, 44.
- Reaction, simple, 117; apparatus for, 118;
forms of (natural or central, complete
or sensorial, abbreviated or muscular),
122 ff.; auditory, 122; cutaneous, 123;
visual, 124.
- Reaction time, definition of, 117.
- Recency, as condition of association, 203,
204.
- Retinal image, formation of, 131.
- Rhythm, definition of, 174; psychology
of, 174 f., 178.
- Ruete, C. G. Th.*, 138.
- Rules, general, of laboratory work, xiv.
- Sanford, E. C.*, 135, 152.
- Sanson's images, 133.
- Saturation, visual, 3.
- Sensation, nature of, 1; investigation of,
2; first problem of, 2; relation of, to
perception, 127, 130.
- Smell, qualities of, 70; and taste, 71 f.;
field of, 73; investigation of, by ex-
haustion, 76; compensations of, 79;
mixtures of, 83; contrasts of, 85.
- Sonometer, 50.
- Sound cage, 179.
- Sound localisation, problem of, 178;
method of, 180; procedures with and
without knowledge, 181 f.; with one
ear, 182.
- Space perception, tactual, problem of,
184; localisation of a single point, 184;
discrimination of two points, 186;
localisation with change of position,
190.
- Space perception, visual, preliminaries to,
130; stereoscopy, 137; pseudoscopy,
144; the geometrical-optical illusions,
151.
- Spectrum, and Hering's ultimate colours,
4; introspection of, 5.
- Speech, cues for, 197.
- Spots, cold, 55; warm, 56; pressure, 59;
pain, 61.
- State of consciousness, 109 f.
- Stereoscope, 139.
- Stumpf, C.*, 47, 116.
- Summation-tone, 40, 45.
- Tartini, G.*, 40.
- Taste, reactions of single papillæ, 64;
number of qualities, 67; contrasts of,
68; and smell, 64, 71 f.; and cutaneous
and organic sensations, 64.
- Temperature, sense of, 53; cylinder,
54; organs of cold, 55; of warmth,
56; sensitivity under areal stimula-
tion, 57.
- Timbre, 46.
- Tones, simple, 31; and noises, 33 f.;
resultant, or third, 40.

Train of ideas, 205; analysis of, 206.

Tuning-forks, 31, 35.

Vernier, P., 120.

Vernier chronoscope, 118; theory of vernier, 120.

Vision, physiology of, 4 f.; stereoscopic, 137, 141 f.; pseudoscopic, 144 f.; illusory, 151.

Visual sensations, classes of, 3; system of, 4; stimulus to, 4.

Vividness, as condition of association, 203, 204.

Volume, bodily, as index of affection, 103, 105.

Wheatstone, C., 144 ff.

Wundt, W., 116, 132, 133, 151 f., 166, 174.

